

SV Series

Scanner/Verifier

Operator's Guide

P/N 252285-001



Stocked, Distributed, and Supported by

SENSORS
INCORPORATED

507 Kelsey Street • Delano, MN 55328
Phone 763-972-1040 Fax 763-972-1041
Toll Free 888-920-0939
Sensorsincorporated.com

RJS

a subsidiary of Printronix, Inc.

14600 Myford Road
Irvine, CA 92606

+1 (714) 368-2781 fax: +1 (714) 368-2354 www.rjs1.com

Table of Contents

PREFACE	2
ENCLOSURE DESCRIPTION.....	4
WARRANTY	6
INTRODUCTION.....	7
LASER BEAM.....	7
RESET BUTTON.....	8
Turn Off Laser Beam.....	8
Perform Calibration	8
Reset Ports	8
I/O CONNECTOR	8
+ 5 VDC Power Input.....	8
Sync Inputs	9
Edge Sync Mode.....	10
Envelope Sync Mode.....	10
Communication Sync Commands	11
Output Ports.....	11
SYSTEM DISPLAYS	11
Power/Sync LED	11
Calibration LED	11
Read LED	11
Indicator LED's 1 and 2	11
SERIAL PORT CONNECTOR.....	12
Serial Port Specifications	12
Serial Port Pin-out	12
SERIAL PORT TRANSMISSION FORMAT	12
INSTALLATION AND SETUP	14
Scanner Positioning	15
Bar Code Travel Direction	16
Bar Code Travel Speed Considerations	16
Picket Fence Direction.....	16
Ladder Direction.....	17
Setting Ladder Mode Scanning Length Using ScanVision Software	17
Calibration	17
Setup Procedure.....	18
Adjusting Scanner Gain and Offset	20
TECHNICAL SPECIFICATIONS.....	21
Physical	21
Environmental	21
MTBF	21
Laser Scanner	21
Scanning Performance.....	21
Scanner Options	21
Power.....	22
Sync.....	22
Outputs	22
SYMBOLOGIES.....	22
OPERATION MODES	22
Sync Mode – Moving Bar Codes	22
Sync Mode – Stationary Bar Codes.....	23
No Sync – Free Scan Operation	23
PARAMETERS ANALYZED	23
SV COMMAND LANGUAGE.....	24
Data Match Commands – B.....	24
Diagnostic Commands - D	27
Hardware Configuration Commands - H.....	28

Label Setup Commands - L.....	30
Output Mode Selection Commands - O.....	35
Output Port Setup Commands - P.....	35
System Control Commands - S	38
OUTPUT INTERFACE MODES DESCRIPTIONS	43
Mode 00 (~LV00).....	43
Mode 01 (~LV01).....	43
Mode 02 (~LV02).....	45
Mode 03 (~LV03).....	47
Mode 12 (~LV12).....	47
Mode 16 (~LV16).....	49
Mode 17 (~LV17).....	51
Mode 18 (~LV18).....	53
Mode 19 (~LV19).....	56
Mode 20 (~LV20).....	58
ANSI PARAMETER GRADE THRESHOLDS	59
APPENDIX A; SV SERIES SETUP HINTS	60
Introduction	60
Setting the Proper Scan Distance.....	60
Setting the Proper Scan Angle.....	61
Calibration Hints	64

Copyrights

The copyrights in this manual are owned by RJS. All rights are reserved. Unauthorized reproduction of this manual or unauthorized use of the SV Series software may result in imprisonment of up to one year and fines of up to \$10,000.00 (17 U.S.C. 506). Copyright violations may be subject to civil liability.

Reference RJS P/N 252285-001
All rights reserved.

PREFACE

Proprietary Statement

This RJS SV Series Operator's Guide contains proprietary information of RJS. It is intended solely for the use of parties operating and maintaining the equipment described herein. This information may not be used, reproduced, or disclosed to any other parties for any other purpose without the express written permission of RJS.

FCC Notice

This device has been tested and found to comply with the limits for a Class B digital device, pursuant to Part 15 of the FCC Rules. These limits are designed to provide reasonable protection against harmful interference in a residential installation. This device generates, uses, and can radiate radio frequency energy and, if installed and used in accordance with the instruction, may cause harmful interference to radio communications. However, there is no guarantee that interference will not occur in a particular installation. If this device does cause harmful interference to radio or television reception, the user is encouraged to try to correct the interference by one or more of the following measures:

- Reorient or relocate the receiving antenna.
- Increase the separation between the computer and receiver.
- Connect the computer into an outlet on a circuit different from that to which the receiver is connected.
- Consult the dealer or an experienced radio/TV technician for help.

Caution: Any changes or modifications not expressly approved by the grantee of this device could void the user's authority to operate the equipment.

Statement of FCC Compliance: Canada

This Class B digital apparatus meets all requirements of the Canadian interference-Causing Equipment Regulations.

Cet appareil numérique de la classe B respecte toutes les exigences du Règlement sur le matériel brouilleur du Canada.

CE:

The unit will contain UL and/or CE quality assurance labels.

This equipment generates, uses, and can radiate radio frequency energy and, if not installed and used in accordance with this operator's manual, may cause harmful interference to radio communications.

Operating this equipment in a residential area is likely to cause harmful interference in which case the user will be required to correct the problem at his own expense.

Statement of RoHS Compliance:

All SV Series units with appropriate part numbers conform to requirements specified in DIRECTIVE 2002/95/EC OF THE EUROPEAN PARLIAMENT AND OF THE COUNCIL of 27 January 2003 on the restriction of the use of certain hazardous substances in electrical and electronic equipment.

Use with UL-Listed Equipment

The SV Series should be used only with printers, applicators, etc. that are UL listed. The SV Series is intended to be supplied by a UL Listed power supply (QQGQ) or (EPBU) or receives power from the host unit (UL Listed Printer), output rated 5Vdc, minimum 300mA maximum 1A.

Documentation Updates

RJS strives to provide the best possible documentation. This manual, or any of our manuals, may be updated without notice.

Laser Safety

- SV100C; IEC Class 3, CDRH Class III
- All other SV models; IEC Class 2, CDRH Class II

Cautions

- Never stare directly into the laser beam.
- Never stare directly at a reflected image of the laser beam.
- Avoid exposure to the laser beam.
- Use of controls or adjustments or performance of procedures other than those specified herein may result in hazardous radiation exposure.
- Use the SV Series only with UL-Listed Bar Code Printers, Applicators, conveyors, etc.
- The following laser light Caution labels must be affixed to your SV Series verifier: If they are not, contact RJS immediately.

Trademarks

The following are trademarks of RJS Systems International:

- RJS
- SV100
- SV Series

Technical Support

Please read this manual before installing an SV Series unit.

If you need assistance over the phone, please have the following information ready:

- Model and serial number of your unit
- Maintenance contract information (if you have a contract)
- Test or diagnostic printout if applicable
- Detailed explanation of the problem or question
- Your company's phone and fax numbers
- Name of vender purchased from

Printronix, Inc.

14600 Myford Road
Irvine, CA 92623-9559
+1 (714) 368-2781 - Phone
+1 (714) 368-2354 - Fax

ENCLOSURE DESCRIPTION

NOTE:

1. MAX THREAD DEPTH INTO PANEL FOR THE 2 6-32 SCREWS: 1/4".

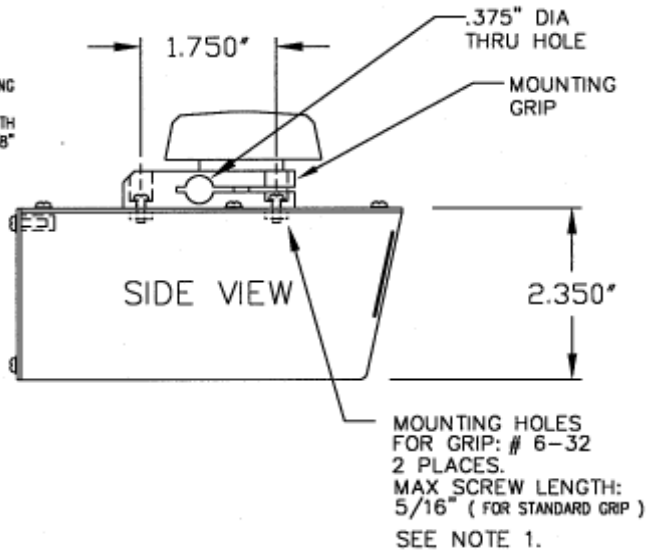
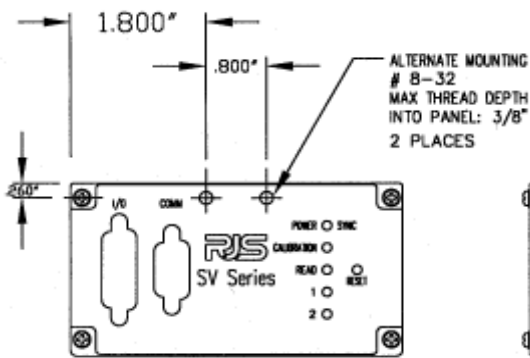
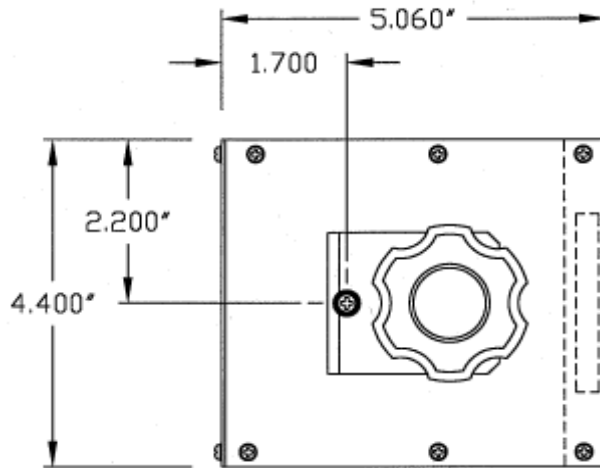

I/O PANEL VIEW:

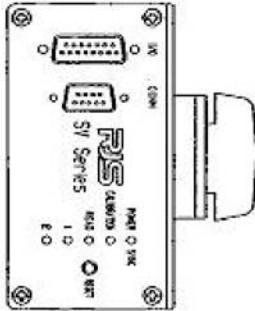

MOUNTING PLATE VIEW:

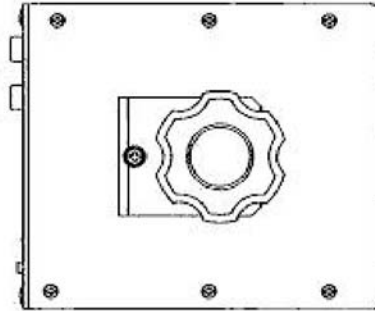

LASER EXIT WINDOW VIEW:

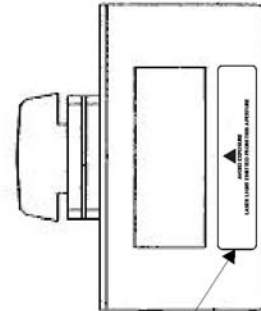

APERTURE

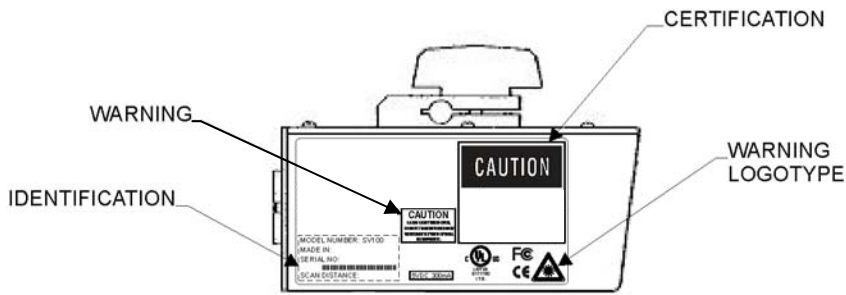

SIDE VIEW:

Maintenance

The SV Series is designed to provide maintenance free operation through its life and contains no moving parts that require maintenance.

Cleaning

The output window should be kept clean by wiping it with a slightly dampened, soft cloth. Dampen with water or a screen cleaner.

Customer Support Offices

Printronix, Inc.
14600 Myford Road
Irvine, CA 92623-9559
+1 (714) 368-2781 - Phone
+1 (714) 368-2354 - Fax

WARRANTY**General Warranty**

RJS warrants the SV Series to be free from defects in material and workmanship for a period of 1 year, under normal use and service, from the date of shipment from RJS' factory location.

The liability of RJS under this warranty is limited to repairing or replacing the defective part and/or unit. RJS may optionally choose to issue credit for any unit returned during the warranty period.

You must promptly notify RJS of any defect in order to receive the full protection of this warranty.

Warranty Limitations

The warranty set forth above is exclusive and no other warranty, whether written or oral is expressed or implied. RJS specifically disclaims the implied warranties of merchantability and fitness for a particular purpose.

RJS is not liable for indirect or consequential damages incurred due to a warranted product's failure that brings about increased costs of doing business.

Service During the Warranty Period

If your SV unit should fail during the warranty period, contact RJS or its authorized representative immediately upon discovery of the defect. RJS' Customer Service Department will provide you with a Return Authorization Number (RMA number).

You will be asked to ship the product in its original packing, freight prepaid, with the RMA number visibly written on the outside of the carton to RJS' factory location.

Be sure to include any samples or printouts or other information that will help us to understand the problem. Your repair will be given priority treatment, or your unit may be replaced at RJS' option. The repaired item will be returned UPS/RPS ground, freight prepaid.

At your request RJS will ship express or overnight if you need premium service and agree to pay the additional cost.

INTRODUCTION

The RJS SV Series of Scanner/Verifiers is designed to be a universal system component that can analyze linear bar code print quality, check encoded data and detect system failures. In its basic mode of operation, an SV unit acts similar to a normal fixed position scanner by automatically decoding bar codes as they pass through its laser beam. Additional capabilities such as performing bar code verification and operating in synchronous modes make the SV Series unique.

The SV Series combines state-of-the-art digital signal processor (DSP) technology, a proprietary high-speed moving beam laser scanner with unique analog output capability and flexible I/O and communications capability. This powerful architecture enables an SV unit to be an economical Quality Assurance tool for practically any bar code printing, applying or conveying system.

The SV Series performs practically every accepted method of bar code verification – ANSI method, traditional method, encoded data format checks and laser scanning type analyses. These wide-ranging analysis parameters can be used to measure bar code quality and detect failure mechanisms for any print technology.

Bar code quality and encoded data information can be reported through the serial communications port for each code analyzed, therefore accountability for all bar codes printed is possible.

An SV Unit's I/O consists of five programmable output ports, two programmable display LED's and a sync input (with two interface circuit choices.) This allows the unit to be used as a local controller for pausing printers, activating lights, gating conveyors, etc.

The SV Series is available in different models. All models operate identically, except the scanner parameters such as scans per second and focus distance are different. Below is a matrix describing standard available models.

SV Series Model Specifications*

	SV100	SV100HD	SV100C	SV200-1	SV200-2
Analyses/sec	100	100	100	200	200
Scan Width	6" (152mm)	4.5" (114mm)	10.5" (267mm)	2.5" (63.5mm)	1.75" (44mm)
Focus Distance	8" (203 mm)	6" (152mm)	15" (381mm)	8" (203mm)	6" (152mm)
X dim (min)	.0067" (.17mm)	.005" (.127mm)	.013" (.33mm)	.0067" (.17mm)	.005" (.127mm)

* Contact RJS Technical Support for information on custom and other models

The recommended setup tool for the SV Series is RJS ScanVision Windows based software. This program makes SV setup simple via menus plus it offers real time monitoring of bar codes being analyzed. This program is available at no charge from RJS and authorized RJS re-sellers. ScanVision can be used to program the SV Series via serial communication using SV Download language. The language is described in this Operator's Guide.

LASER BEAM

The laser beam may be on at any time the Power/Sync LED is illuminated.

RESET BUTTON

The Reset button is multifunctional.

Turn Off Laser Beam

The laser beam may be turned off (therefore turning off the SV unit's scanning operation) by holding down the Reset button for a few seconds until the beam turns off. Pressing the Reset button again will begin normal scanning operation.

Note: there are some modes of operation when the laser beam is on only during specific scanning times (see the ~SA Command in the SV Command Language Section.) Using the Reset Button for turning off the system is not recommended in these modes.

Perform Calibration

The reset button is used in the calibration procedures. See the Calibration Section for details.

Reset Ports

Pressing the Reset button will reset ports to their inactive states. This is useful in systems where the SV unit is holding a printer in PAUSE mode and the user desires to clear the pause condition. See the Output Ports Section for details.

I/O CONNECTOR

The I/O connector is used for all power and field interconnections. The connector is a DB 15 male. Pin-outs are shown below:

- 1 - Isolated synchronization input (+)
- 2 - Isolated synchronization input (-)
- 3 - GND
- 4 - Switch synchronization input
- 5 - Output Port 1
- 6 - Output Port 2
- 7 - Output Port 3
- 8 - Output Port 4
- 9 - Reserved
- 10 - Reserved
- 11 - GND
- 12 - +5 VDC power in
- 13 - Power GND
- 14 - GND
- 15 - Output Port 5

+ 5 VDC Power Input

The SV Series requires + 5 Volts DC, +/- 0.25 Volt. Maximum current consumption is 1 amp. The voltage input must be connected to pin 12 and the ground input should be connected to pin 13 on the I/O connector.

The alternate ground pins (3, 11 and 14) may be used for power ground or for connecting the ground(s) of an external device(s) (such as presence sensors) that may be powered from a different source than the verifier power input.

Sync Inputs

Utilizing a sync signal is recommended for all applications using hardware (as opposed to communication) interfaces. (Also see Operation Modes Section.) A sync signal is used to synchronize the SV Series to an object, label, etc. that contains the bar code(s) being analyzed as it passes through the laser beam. The SV Series should be programmed for the number of bar codes expected per sync interval. This ensures a robust system that can report all undetectable bar codes due to printer failure, missing labels, etc. along with quality and data information on bar codes that are fully or partially decoded.

Two hardware sync inputs are available. Pin 4 is designed to be used with ttl or open collector inputs. For open collector inputs, adding an external pull-up resistor to 5 VDC is recommended because the internal pull-up is a relatively high 100 K ohm resistance. Pins 1 and 2 form a ground isolated input designed to be used with systems that need separate grounds than the verifier and/or output a higher voltage level than ttl. See figures C1 and C2 for circuit diagrams.

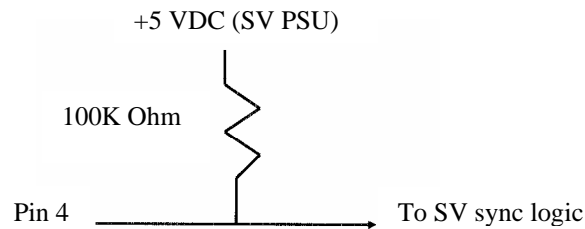

Figure C1 – ttl Sync Input Diagram

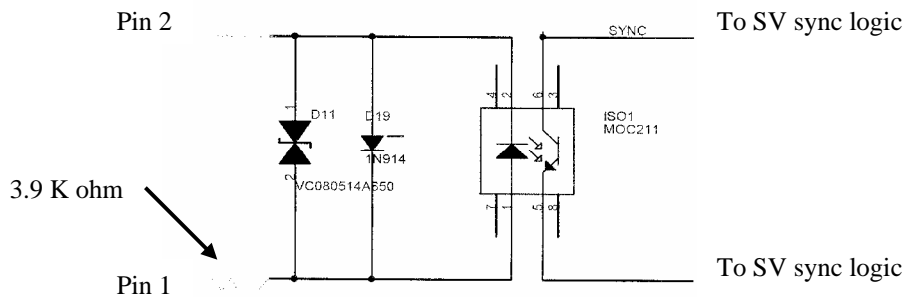

Figure C2 – Isolated Sync Input Diagram

Sync inputs are also available via serial communications. See the ~SK command for details.

Hardware sync operation is very flexible due to programmable options. Two sync modes – edge and envelope – are available. Signal input polarity is also user programmable.

Please see the Operation Modes Section for more information on use of these sync modes.

Edge Sync Mode

This mode senses a signal transition level of a sync signal as shown in Figure S1.

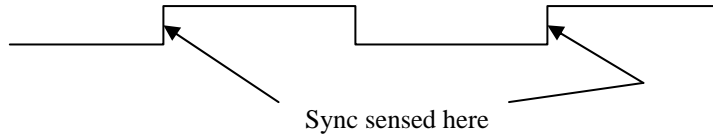

Figure S1 – Edge Sync

Figure S1 shows the sync operation of an SV unit programmed to sense the rising edge of a sync signal in edge mode. Each time a rising edge is sensed, the SV unit does the following:

1. It verifies that at least the number of bar codes expected (programmed) since receiving the last sync input have been fully decoded. If not, a No Read condition is internally set for possible reporting through communication or output activation.
2. It begins a new interval, counting the bar codes analyzed until the next sync input is received.
3. A Serial communication report is transmitted and an output port is updated per its programmed function each time a bar code is analyzed.

Envelope Sync Mode

This mode senses two (leading and trailing) transitions of the sync signal to determine when to begin and end the period for determining missing bar codes as shown in Figure S2 below.

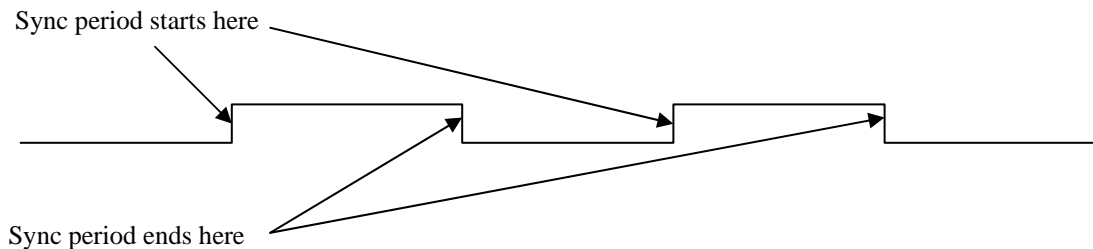

Figure S2 – Envelope Sync

Figure S2 shows the sync operation of an SV unit programmed to sense the rising voltage edge as the start of a sync period. The SV unit operates in this mode as follows:

1. Upon receipt of the starting edge of a sync signal, the unit begins counting the bar codes being scanned and analyzed.
2. A Serial communication report is transmitted and an output port is updated per its programmed function each time a bar code is analyzed.
3. Counting ceases upon receipt of the trailing edge of a sync signal. The SV Series determines that at least the number of bar codes expected (programmed) during the sync period have been fully decoded. If not, an internal No Read condition is set for possible reporting through communication or output activation.
4. The SV unit then waits for the next leading edge of a sync signal to begin counting codes being scanned and analyzed.

NOTE: In either sync mode, for best performance, mount the SV unit in a location where a bar code is not in the laser beam when an active edge signal is received.

Communication Sync Commands

Sync operation can be accomplished through serial communications. Please see the ~SK command for details.

Output Ports

Five programmable output ports are available on I/O connector pins 5, 6, 7, 8, and 15. Each port can be programmed to activate on practically any combination of data and analysis parameters (including “good codes”) analyzed by the SV Series. Port activation logic and parameters are programmed via the output interface modes and associated commands. See the Output Interface Modes Descriptions section for details.

Each port’s output is an open drain FET (field effect transistor). Therefore, the port can either be “ON” (sinking current) or “OFF” (no current/open circuit.) The active polarity determines whether the port is “ON” or “OFF” while active. This type of output circuit is used because it is flexible for field connections. Figure C3 shows an example circuit diagram of one output port.

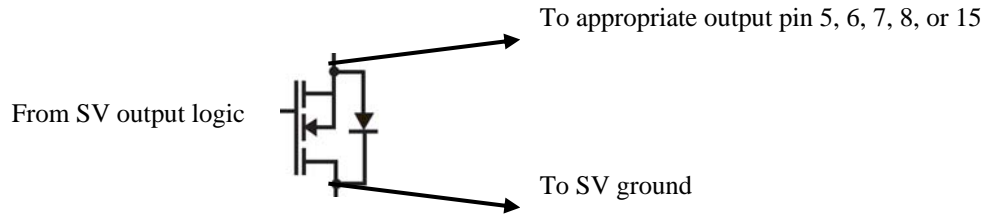

Figure C3 – Open Drain FET Output Diagram

SYSTEM DISPLAYS

Five LED’s are included on the SV Series back panel.

Power/Sync LED

This LED is illuminated green whenever power is applied to the SV Series. Upon receipt of any sync input (hardware or serial communications) the LED will blink yellow for approximately 100 milliseconds.

Calibration LED

This yellow LED indicates calibration status. Please refer to the Calibration Section for details.

Read LED

This green LED is illuminated whenever a bar code is being fully decoded.

Indicator LED’s 1 and 2

These two green LED’s are user programmable exactly like the five output ports. Their functions are intended for use as indicators for specific analysis results.

A common example is LED 1 programmed to illuminate in latch mode whenever a symbol quality error is detected, while LED 2 is programmed to illuminate in latch mode whenever a No Read error is detected.

SERIAL PORT CONNECTOR

The serial port connector is used to interface the SV Series with devices incorporating RS-232C signal levels. The connector is a DB 9 male.

The serial port can be used for reporting bar code analysis results to a host and receiving SV Command Language instruction from a host.

Serial Port Specifications

- Baud rate: programmable between 9600 and 115200 baud
- Protocol: Echo back
- Data: 8 bit, no parity, 2 stop bits
- RS 232C compatible

Serial Port Pin-out

<u>Pin</u>	<u>Function</u>
2	Receive Data (RXD)
3	Transmit Data (TXD)
4	Data Terminal Ready (DTR)
5	Ground
7	Request to Send (RTS)
8	Clear to Send (CTS)

SERIAL PORT TRANSMISSION FORMAT

The following data transmission format is standard in the SV Series. This is the format used by ScanVision software for setup and monitoring of SV Series data. All parameters analyzed for each bar code scanned are transmitted in the following order:

YabbcdddeeffghhijjkkllmmnooppqrsstttuuvwxxxxPPPPyyMNzzzzAAAABBBB
CCDDDEEFFGGHHIIJJOKLL[bar code data chars]Z

Characters designated 'a' through 'O' represent values for Parameters analyzed which are described below. For more parameter details, see the Parameters Analyzed Section.

Legal values for each parameter are;

	<u>Pos</u>	<u>Chars</u>	<u>Parameter</u>
Y	1	1	Programmable ASCII character indicates start of transmit: See ~SSbbbeee command. CR (carriage return) required for ScanVision.
a	2	1	P=PASS Ref Decode, F=FAIL per Ref Decode algorithm. P and F are a majority decision over all scans
b	3	2	00-9A (0-100); Decodability calc. avg. over all decoded scans
c	5	2	00-9A; Modulation calc. avg. over all decoded scans
d	7	2	00-9A; Defects calc. avg. over all decoded scans
e	9	2	00-9A; Edge Contrast calc. avg. over all decoded scans
f	11	2	00-9A; Rmin/Rmax calc. avg. over all decoded scans
g	13	2	00-9A; SymbolContrast calc. avg. over all decoded scans
h	15	2	00-9A; PCS calc. avg. over all decoded scans
i	17	2	00-9A; R(white) calc. avg. over all decoded scans

	<u>Pos</u>	<u>Chars</u>	<u>Parameter</u>
j	19	2	00-9A; R(black) calc. avg. over all decoded scans
k	21	2	00-99; Ratio calc. avg. over all decoded scans Example: 29 represents a ratio of 2.9
l	23	1	+ or - indicating sign of avg. bar deviation calculation. + indicates wide bars.
m	24	2	Bar deviation calculation averaged over all decoded scans. Units are % of X. Value: 00-9A (signify 0 – 100)
n	26	1	+ or - indicating sign of avg. min. bar deviation calculation. + indicates wide bars.
o	27	2	Minimum bar deviation calculation averaged over all decoded scans. Units are in % of X. Value: 00-9A (signify 0 –100)
p	29	1	+ or - indicating sign of avg. max. bar deviation calculation. + indicates wide bars.
q	30	2	Maximum bar deviation calculation averaged over all decoded scans. Units are in % of X. Value: 00-9A (signify 0 – 100)
r	32	1	One character: Pass(P) or Fail(F). Quiet Zone. Pass requires approx. 80% min. of all scans on the code to have an acceptable quiet zone analysis. (Note: the ~PB816 command provides a programmable decision threshold for output port manipulations.)
s	33	2	00-9A; Percent decode calc. avg. over all decoded scans
t	35	3	Absolute X dimension in 0.1 mil (.0001 inch) resolution. Example: a value of 120 represents a 12 mil X dimension.
u	38	2	Overall ANSI method symbol grade (numeric) Ave over all decoded scans. Example: 26 = 2.6
v	40	1	Bar code decoding direction: Forwards(0) or Backwards(1)
w	41	3	000-999; Calculated symbology mod check value, Code 93 mod check C
x	44	4	4 hex digits, records output count
P	48	4	4 hex digits; self check value
y*	52	2	Two digit number identifies the symbology. See Symbology Identifier Table for details.
M*	54	1	Digit: 0 = no error, 3 = symbology mod check error, 4 = subsymbology mod check error, 1, 2, 6 , or 7 = partial decode error
N*	55	1	Digit; 0 = no error, 4 = data match field length error, 5 = data match and Decrement error, 6 = data match and increment error, 7 = decrement error, 8 =increment error, 9 = data match error
z	56	4	Four digit number indicates bar code horizontal position.
A	60	4	Four digit number indicates bar code vertical position.
B	64	3	Three digit number shows good scans-on-code. (00-9A)
C	67	3	Three digit number shows total scans-on-code.
D	70	3	000-999; Good Quiet zones (scans).
E	73	2	Two digit number shows Lead QZ. Units: .1X (00-9A)
F	75	2	Two digit number shows Trail QZ. Units: .1X (00-9A)
G	77	1	One digit number: '0' (off), '1' (on). Sync state.
H	78	2	IGC, two bytes: Units of X dimension times 10. Value=00 when N/A
I	80	2	Two digits; Percent of good global Thresholds. (00-9A)
J	82	2	Two digits; Calculated application checksum value or Code 93 mod check K
O	84	1	One digit; indicates the subsymbology enabled in the y field of ~LFxy command for this symbol. A value of 0 indicates no subsymbology check is enabled.
K	85	1	One digit; buffer overrun indication; 0=no overrun

	<u>Pos</u>	<u>Chars</u>	<u>Parameter</u>
L	86	2	Two digits; decode header indicator “^^”
[chars]	88	...	Bar code data characters (variable length).
Z	last	1	Programmable ASCII character indicates end of transmit; See ~SSbbbee command. LF (line feed) required for ScanVision.

y* - **The symbology identifiers use groups of numbers to identify each symbology.** The range of possible values could potentially span 100 for each symbology category. The Symbology Identifier Table lists each identifier group with the corresponding symbology.

*** A no read condition is indicated by all four bytes yy, M and N set to 0 in a transmission. All other data is therefore not valid.**

See the ~OS# command for other transmission data formats.

Symbology Identifier Table

<u>Identifiers</u>	<u>Symbology Category</u>
02	I 2 of 5
03	Code 128
04	Code 93
05	Code 3 of 9
06	Codabar
11	UPC-A
15	UPC-A w/add-on (2)
19	UPC-A w/add-on (5)
12	EAN-13
16	EAN-13 w/add-on (2)
20	EAN-13 w/add-on (5)
13	EAN-8
17	EAN-8 w/add-on (2)
21	EAN-8 w/add-on (5)
14	UPC-E
18	UPC-E w/add-on (2)
22	UPC-E w/add-on (5)

INSTALLATION AND SETUP

Scanner positioning and proper system setup are extremely important for proper SV Series operation. The following sections describe the most common setup possibilities in detail. Some knowledge of SV Series operation is recommended to best follow the steps. *Please review **Appendix A – SV Series Setup Hints** – for a more basic description of SV Series operation and scanner positioning and calibration.*

Scanner positioning is the most important step in an installation. Positioning is important in order to provide accurate analyses and maximum decoding performance. The scan distance must be set accurately to achieve the proper beam focus in order to detect printer flaws and failures such as a worn ribbon (matrix printing), low toner (laser printing), voids (flexo printing), burned pixels (thermal printing), etc. The scan angle is important to accurately measure bar code and substrate reflectance values. Setup is important to ensure proper interface to print mechanisms, host computers, etc.

Scanner Positioning

Each SV Series has an attached label that indicates the type of scanner, focus distance and recommended scan angle. Use the scan distance and scan angle information to mount the scanner per Figure 2.

Figure 2 – Scanner Positioning

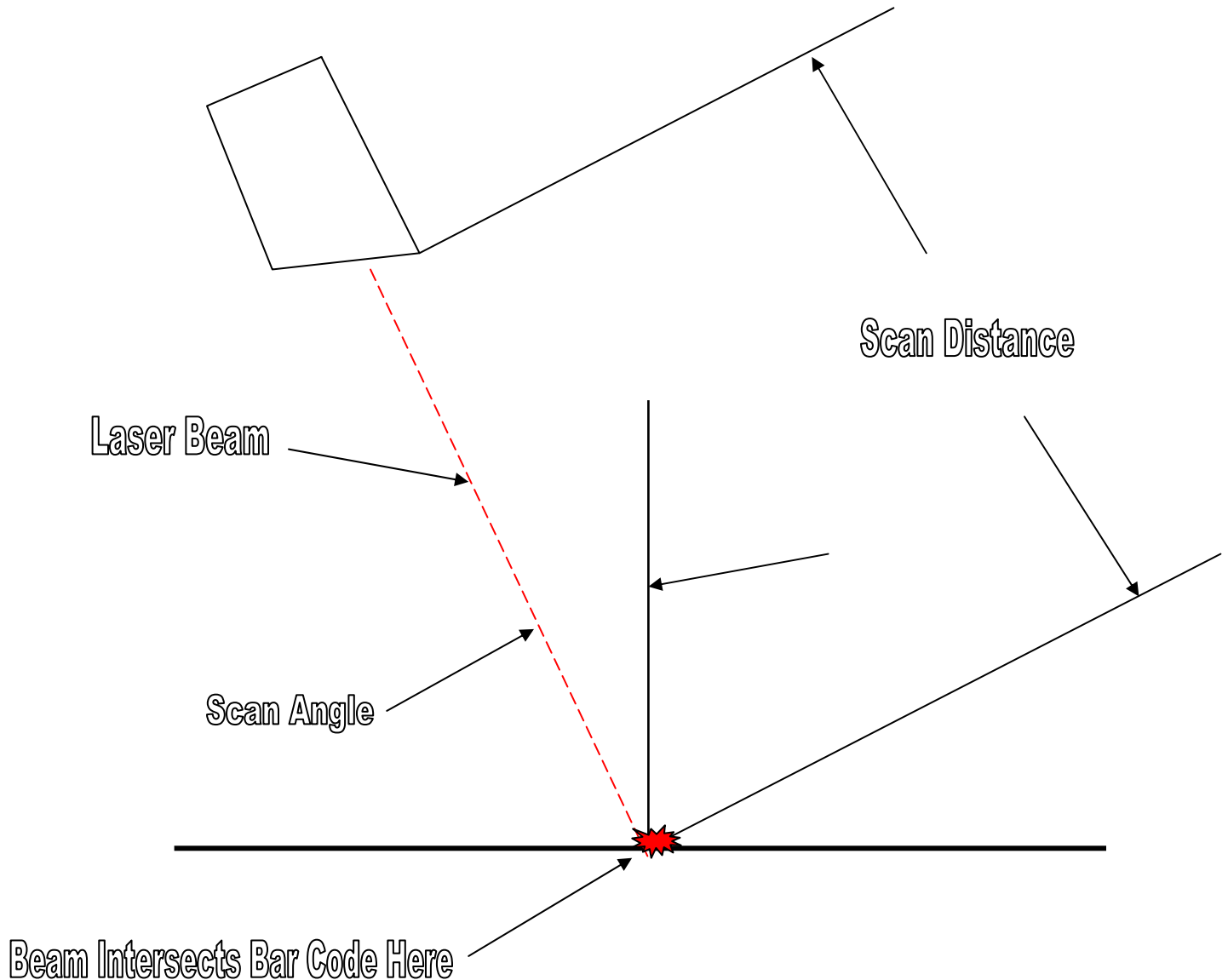

Notes:

1. Scan distance is measured from the protruding edge of the face of the scanner.
2. Scan angle is measured in degrees relative to vertical from the surface of the bar code.
3. The scanner can be mounted in any orientation, the figure is meant to show the beam angle relative to the bar code placement in the beam.

Bar Code Travel Direction

Bar codes can be scanned in a static location, or more commonly with on-line scanner/verifiers, they can be scanned while moving through the laser beam. Refer to Figure 3. It shows the two directions a bar code can travel through the laser beam. They are designated “picket fence” and “ladder” directions.

Figure 3 – Scan Direction

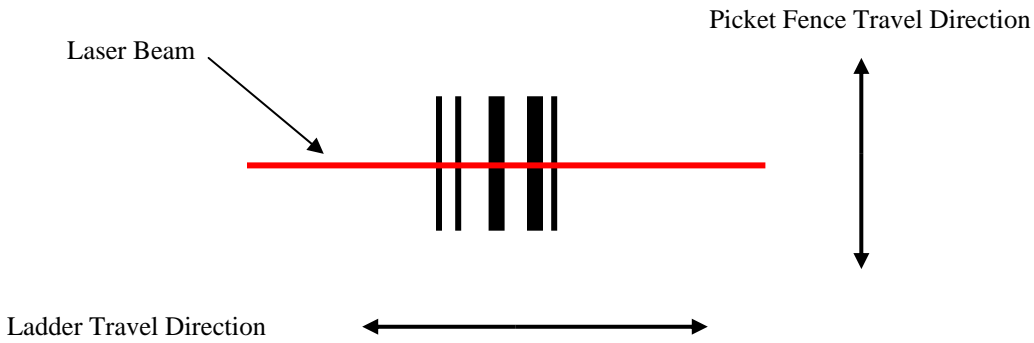

The SV unit must be programmed for the direction of travel of the codes being analyzed. If the codes are being scanned in a static condition, use picket fence travel direction.

Bar Code Travel Speed Considerations

A bar code should be present in the beam for at least five scans for most reliable operation. The SV Series performs a minimum of 100 scans/analyses per second. At that rate, each analysis is accomplished in 10 milliseconds max. Therefore, a bar code must be in the beam for at least 50 milliseconds to be reliably analyzed. Some SV models have higher minimum scans/analysis, therefore a bar code must be in the beam for less amount of time for those models.

Picket Fence Direction

In picket fence travel direction, a bar code is in the laser beam throughout the height of the shortest bar in the code. An easy way to estimate the fastest speed the code can travel through the beam is to divide the height of the shortest bar in the code by the maximum time required for the SV unit to take five scans of the code. Example: Calculate the maximum travel speed where the shortest bar height in a code is .5 inches and the SV model being used performs a minimum of 100 scans/analyses per second. Five scans requires 50 milliseconds (.05 seconds) to gather, so .5 inches (bar code height) divided by .05 seconds (time needed to gather 5 scans) = 10 inches/second. Therefore the maximum speed the code can travel through the beam is 10 inches per second.

Vertical distance between bar codes is also a speed consideration in picket fence direction. The SV Series must have five continuous scans where no bar code is detected to reliably exit a bar code when operating in the standard operation mode set by Command ~HO1. Assuming 100 scans per second minimum, this means the vertical distance between the codes must take at least 50 milliseconds to pass through the laser beam. Calculate the maximum speed by measuring the shortest vertical space between bar codes on a label (or between labels.) Divide this distance by .050 (seconds). The result is the fastest speed the codes can move through the beam. If the application travel speed cannot be met due to a short vertical distance between codes, Command ~HO2 can be used to cause the SV to exit on a change in data rather than detecting no bar code. **If using ~HO2, ensure the bar codes with short vertical gap are encoded with different data and only one code across is being analyzed in each scan.**

The slower of the two print speeds calculated above for bar height and gap height is the maximum recommended speed for picket fence travel.

Picket Fence Bar Code Positioning Specifications:

- Four codes across maximum
- Horizontal gap between codes: .5 inch (13 mm) minimum
- Maximum number of codes per sync period: 99

Ladder Direction

In ladder direction, one bar code at a time is usually in the beam. The amount of time the code is in the beam is a function of the total width of the code (including quiet zone), the length of the beam area that is used for scanning and the speed the code is travelling. The distance the bar code is in the beam is calculated by subtracting the bar code width from the length of the beam programmed to scan the bar code. (See Setting Ladder Mode Scanning Length Section below.) Divide this difference by the amount of time the SV model requires to gather 5 scans to get the maximum speed. Example: a bar code with total width of 3 inches is to be analyzed in a beam length of 6 inches and the SV model being used performs a minimum of 100 scans/analyses per second. Maximum speed of travel is $(6 - 3) \text{ inches} / .050 \text{ seconds} = 60 \text{ inches per second}$ in ladder direction.

Setting Ladder Mode Scanning Length Using ScanVision Software

The distance and location in the laser beam where a bar code is scanned sometimes must be tuned (programmed) for a particular ladder mode application. In general, the wider the length, the faster the bar codes can travel. In some cases, a narrower scan length is required to mask an adjacent code so only one code at a time is scanned. Instructions for using ScanVision software to program the scanning length is provided in the Setup Procedure Section.

Calibration

Calibration is required if any reflectance calculation (symbol contrast, Rmin, PCS, etc.) is used in the application. It is recommended to calibrate the unit in any case during initial setup to ensure the scanning distance and orientation is within device limits. A calibration symbol is supplied with each SV unit as a standard component. Store it in a clean location.

The SV Series can be calibrated using either of the two following procedures:

Procedure 1:

1. Remove all bar codes from the laser beam path.
2. Place the supplied calibration symbol in the laser beam in the same position (distance and angle) as the labels to be verified will be scanned.
3. Press and hold the RESET button on the SV unit until the Calibration LED begins to flash.
4. Release the RESET button immediately after the Calibration LED begins flashing.
5. If calibration is successful, the laser beam will go off and the Calibration LED will go off. **Remove the calibration symbol from the beam path** and Press the RESET button until the beam turns on. The SV unit is now ready to operate.
6. If calibration is unsuccessful, the Calibration LED will be either on steadily or flashing. In this case, repeat the calibration procedure.

Procedure 2:

1. Place the supplied calibration symbol in the laser beam in the same position (distance and angle) as the labels to be verified will be scanned.
2. Send “~SC” into the SV unit serial port. This will cause the Calibration LED to flash.
3. If calibration is successful, the laser beam will go off and the Calibration LED will go off. **Remove the calibration symbol from the beam path** and then Press the RESET button until the beam turns on. The SV unit is now ready to operate.
4. If calibration is unsuccessful, the Calibration LED will be either on steadily or flashing. In this case, repeat the calibration procedure.

Once calibration is successful, re-calibration is not required unless the unit has been moved – either on its mounting stand or into a new location. It is advised to keep the laser beam exit window clean. Dirt, dust, fingerprints, etc. on the exit window can affect calibration.

Setup Procedure

It is highly recommended that RJS ScanVision be used to set up SV Series units. This Windows based software is available free of charge from RJS. The alternative is to use SV Command Language through a host computer. See the SV Command Language Section for details.

Installation of an SV scanner/verifier requires proper mounting position, port configuration(s) and LED configurations to ensure reliable and accurate operation. This section describes the procedures for using ScanVision to ensure proper SV setup and installation.

Each SV unit has a label showing the specified mounting distance and target scan angle for its particular scanner. Follow the steps below to ensure the SV unit is properly mounted and programmed.

1. Mount the SV unit at the proper distance and angle. Use Figure 2 as a reference.
2. Connect power and communication cables to the SV unit.
3. Set the SV unit for picket fence bar code travel direction.
4. Place a sample bar code in the center of the intended laser beam path. For best results, this sample should match the type of bar code(s) and material that is to be analyzed in the final application. Knowing the X dimension (narrow element width) of the bar code(s) is a big plus as will be seen in Step 5. *Note:SV Calibration symbols have a 10 mil X dimension unless otherwise indicated.*
5. Take a Scan Profile with ScanVision.
 - a. Ensure the bar code(s) is in the center of the scan path.
 - b. Ensure the scan profile contains no distortion from light reflecting from objects in or near the light path. **Examples of a good and bad reflectance profile are shown in Figures 4a and 4b respectively at the end of this section.** One major aspect in a good profile is the low reflectance points (the bars) in the symbol are uniform all the way across the code. Optimum signal amplitude should be adjusted so the bar code element reflectances are between the 90% and 10% marks shown in yellow on the screen. Scanner angle has the most effect on the signal amplitude.
 - c. Continue adjusting the SV unit's placement until a good, centered scan profile is obtained. The scan angle may have to be altered slightly or a light shield may have to be installed in extreme cases to achieve a good reflectance profile. If adjustment of scan angle does not produce the correct signal amplitude or placement, adjust scanner gain and offset per the Adjusting Scanner Gain and Offset Section.
6. * Place ScanVision in Session Mode.
 - a. Click on the Report an Analysis Speedbutton.
 - b. Ensure that X in the lower panel of the Bar Code Analysis Screen matches the X dimension of the symbol within +/- .1 mil.
 - c. Adjust distance of the SV unit from the bar code until the X dimension matches the desired value. (If X is analyzed as too large, move the scanner farther away; if X is too small, move the scanner closer.)
7. Repeat steps 5 and 6 until no more mounting adjustments are required.
8. Remove the symbol from the laser beam path.
9. Program the SV unit's ports, LED's, sync mode, etc. (if required).
10. Calibrate the SV unit if any reflectance parameters (such as symbol contrast) are programmed in this application to report to a host or activate any ports. Each SV unit is supplied with a calibration symbol.
11. The SV scanner/verifier is now ready to operate for picket fence bar code travel direction. If Ladder Mode is being used and the desired scanning length for ladder bar code travel direction is programmed, place the unit in ladder mode. The unit is now ready to operate. If ladder mode scanning length is to be programmed, continue with the following steps.
12. Turn off partial decodes using the ~Lp0 command.
13. Display additional results in ScanVision through the Advanced Menu.
14. ** Place a sample of a bar code that is to be analyzed on the farthest position towards the left end of the laser beam where the code is intended to be scanned.

15. Analyze the code by clicking the ScanVision Report an Analysis Speedbutton.
16. Confirm the code is being read and analysis results are proper. If not, move the code to the right until acceptable analysis results are achieved.
17. Record the value of the “Hor Pos” value in the additional parameters for the acceptable analysis. This value will consist of four digits. This value will be used for the “Set Ladder Start Position” setting later in the procedure.
18. Move the code to the farthest position towards the right end of the laser beam where the code is intended to be scanned.
19. Similar to steps 15, 16 and 17, obtain an acceptable analysis and record the “Hor Pos” value for the acceptable analysis. This value will be used for the “Set Ladder Stop Position” setting later in the procedure.
20. Place the unit in Ladder mode through the Setup Menu. Place the proper values for the “Set Ladder Start Position” and “Set Ladder Stop Position” boxes during menu process.
21. Enable partial decodes if desired for this application.
22. The unit is now ready to operate for ladder bar code direction.

***This step is not mandatory, but highly recommended. Scanner focus is dependent on the scan distance. Good focus maximizes the SV Series’s ability to detect printer errors and failures. If this step is omitted, take extra precaution in setting and measuring the scan distance.**

**** This procedure assumes the SV unit is mounted as shown in Figure 2 with the protruding surface up and the user is looking at the beam from behind the SV unit. In this orientation, the beam is sweeping from left to right.**

Figure 4a – Good Reflectance Profile

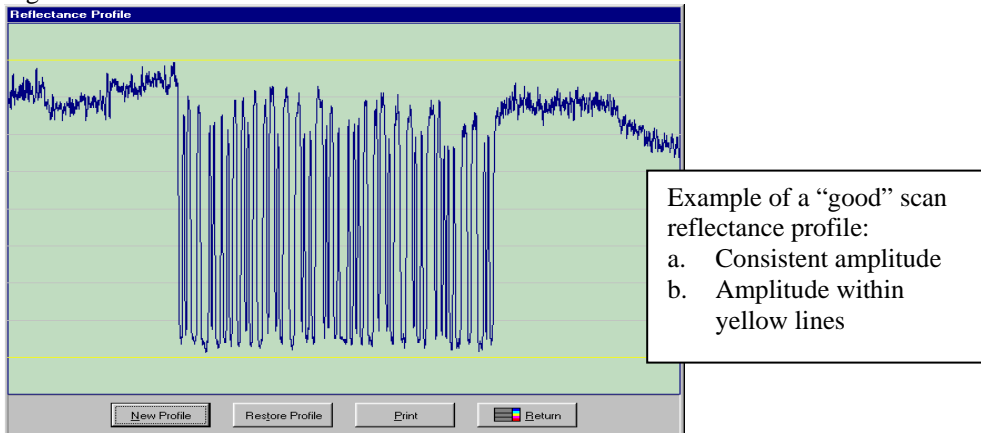
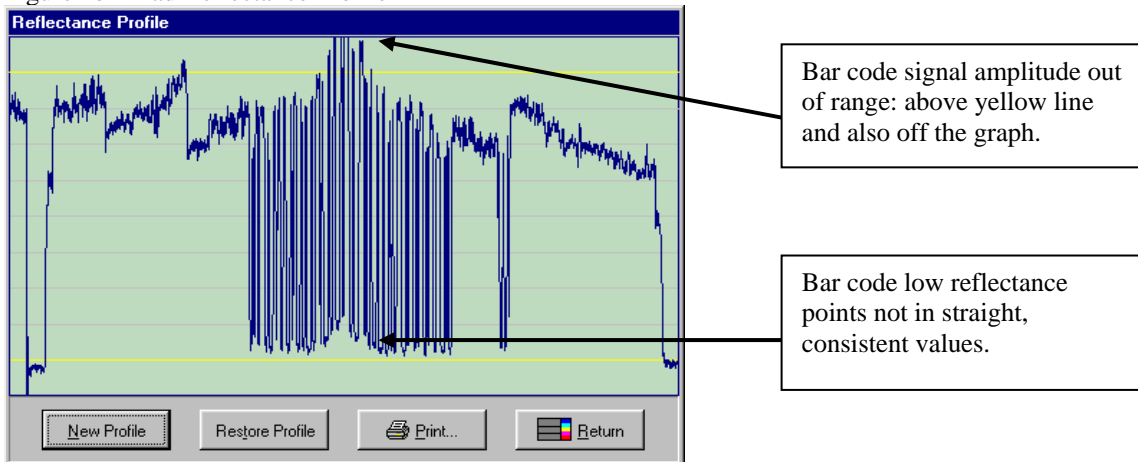

Figure 4b – Bad Reflectance Profile



Adjusting Scanner Gain and Offset

Scanner gain and offset adjustment via commands is available in SV units that have the “A” circled on the label that indicates focus distance. The adjustment capability is useful for adapting the unit to various material types and scanning angles during the setup procedure. Knowledge of RJS ScanVision software is required for best understanding of the following description.

When setting SV scanner gain and offset, use ScanVision Reflectance Profile Mode as the guide to viewing signal levels. The object is to have at least 6 lines high of signal amplitude for the bar code(s) being verified. The bar code signal vertical placement (offset) should be within the yellow lines to ensure the signal is in the linear range. All other objects’ amplitudes and placements are not important. A picture of a “good” signal level is shown below in Figure 5.

To adjust gain and offset settings, first use the ScanVision Transmit SV Commands Screen to send a ~HT command to the SV unit. In the reply, look for the line that reads [DACs] = nnn nnn nnn nnn where nnn = numeric values. Example: a unit may read: [DACs] = 201 146 255 255. This indicates the current settings.

1. The 201 indicates the value of the gain setting. The higher the value, the higher the gain and therefore the higher the amplitude of the scan profile for a symbol. Max value is about 225.
2. The 146 value indicates the offset setting. The higher the value, the lower the symbol placement is offset on the graph.
3. The command ~Hd101nnn sets gain where nnn is the three digit value.
4. The command ~Hd201nnn sets offset where nnn is the three digit value.
5. Use these commands to set the desired signal amplitude (~Hd101nnn) and locate the signal vertical placement between the yellow lines (~Hd201nnn.)
6. A few iterations of commands will probably be needed, therefore it will be necessary to access the Transmit SV Commands Screen and Reflectance Profile Mode alternately. *Note: A short cut to the Reflectance Profile Mode is accessed by pressing F3.*
7. Like most other SV commands – new scanner settings are enabled immediately when received, but to be stored to non-volatile memory so they are maintained on a power up condition, the ~Hx command must be transmitted after the desired settings are achieved.

Figure 5 – Desired Signal Amplitude and Placement

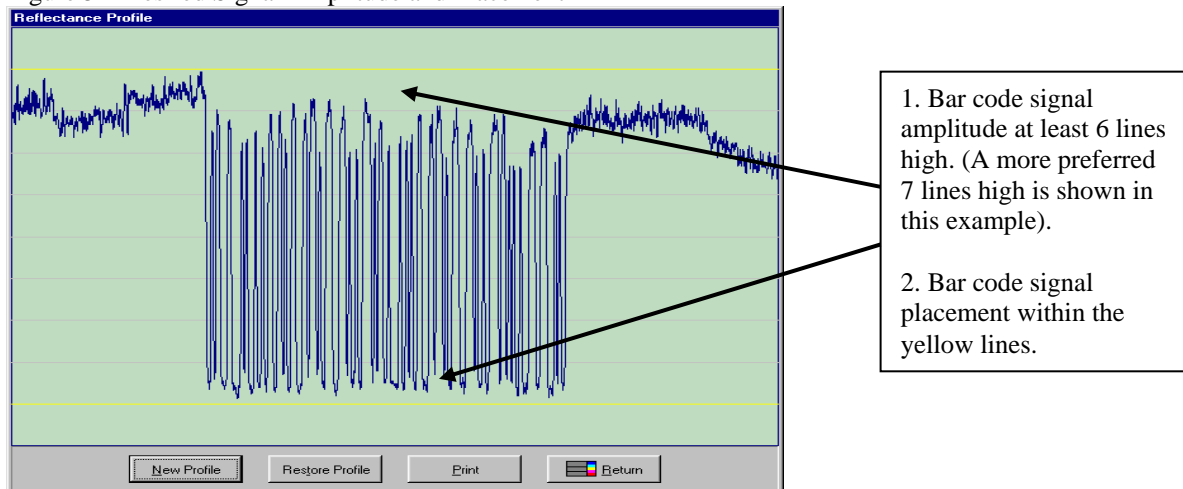

TECHNICAL SPECIFICATIONS

Physical

- Package: 4.4" (112 mm) x 2.4" (61 mm) x 5.2" (132 mm)
- Indications: 5 LED's – Power/Sync, Calibration, Read, 2 programmable LED's 1 and 2
- Comm Port: DB-9 male, RS 232C, programmable baud rate up to 115200 baud
- I/O-Power: DB-15 male, 5 programmable outputs, 2 sync inputs
- +5VDC @ 1 amp required
- Mounting: 2 sets of mounting holes on 2 different surfaces or a clamp for tightening to a 3/8" (9.5 mm) rod

Environmental

- Operating Temperature: 40°F to 105°F (4°C to 41°C)
- Storage Temperature: -4°F to 140°F (-20°C to 60°C)
- Humidity: 10% to 90% non-condensing
- Ambient light: Not to exceed 0.5 mWatts/sq-mm 600 nm to 700 nm (this is calculated at about 2 percent of light level—estimate, not verified)

MTBF

- 10,000 hours (est.) Dominated first by motor life, second by laser life.

Laser Scanner

- Scan rate: 400 scans/second (s/s), +/- 2 s/s
- Laser power: 3.0 mW, +/- 0.5mW – except SV100C: 5mW +0 mW/- .5 mW
- Wavelength: 650 – 680 nm
- Beam shape: elliptical, RJS proprietary design for detection of print failure mechanisms.
- Class 2 Laser Product – except SV100C is Class 3a; see labeling details in Caution Section of Preface

Scanning Performance

- SV Series Model Specifications*

	SV100	SV100HD	SV100C	SV200-1	SV200-2
Analyses/sec	100	100	100	200	200
Scan Width	6" (152mm)	4.5" (114mm)	10.5" (267mm)	2.5" (63.5mm)	1.75" (44mm)
Focus Distance	8" (203 mm)	6" (152mm)	15" (381mm)	8" (203mm)	6" (152mm)
X dim (min)	.0067" (.17mm)	.005" (.127mm)	.013" (.33mm)	.0067" (.17mm)	.005" (.127mm)

* Contact RJS Technical Support for information on custom and other models

- All Models - 4 bar codes across max. (picket fence direction)

Scanner Options

Scanners can incorporate options for special optics and/or be focused for special applications. Contact RJS Technical Support and describe your application for assistance. Below are two standard options available.

High Density Focus: Analyze bar codes with 5 mil X dimension

Custom focus distances are available to achieve various spot sizes – contact RJS Technical support for details.

Power

- +5 Volts DC, +/- .25 Volt
- 1 amp maximum

Sync

See the Sync Inputs Section for more details

I/O connector pin 4 input:

- ttl switching level threshold
- Maximum input voltage swing: +/- 12 VDC
- 100 K ohm internal pull-up resistor to 5 volts DC

I/O connector pins 1 (+), 2 (-) isolated input:

- 24 Volts DC nominal input for sensing
- 30 Volts DC maximum input, approximately 15 Volts minimum for sensing
- This input is ground isolated from 5 VDC power
- Sync input recovery time: 12.5 milliseconds minimum

Outputs

- Open Drain FET (Field Effect Transistor) – no internal pull-up resistor
- External Pull-up Voltage: 0 - 30 Volts DC
- Sink current: 100 milliamps maximum

SYMBOLOGIES

- USS Code 128
- USS Code 39
- USS Code 93
- USS Codabar
- USS Interleaved 2 of 5
- UPC versions A and E (including 2 and 5 digit supplemental codes)
- EAN-13 and EAN-8 (including 2 and 5 digit supplemental codes)

OPERATION MODES

The SV Series is very flexible, with many programmable features, but basic system operation can be broken down into three modes. Two modes include a sync signal and one mode operates without a sync signal. These modes are programmable via SV Command Language and RJS ScanVision software.

Sync Mode – Moving Bar Codes

In this mode, a sync signal is used as an indicator to determine when an object or label containing a bar code(s) has entered or exited the laser beam. Bar codes are analyzed and ports activated, transmissions sent, etc. as the bar codes pass through the beam. The SV unit is programmed for the number of bar codes to expect during a sync period (see Sync Input Section), therefore the SV unit can detect missing or undetectable bar codes.

A hardware input is the most common sync source for this mode.

***Note:** When in this sync mode, the sync input is a background application. The SV Series will scan, analyze and report on bar codes as they pass through the beam in this mode, regardless if a sync signal is sensed. The presence of a sync signal allows the number of codes expected (programmed) during the sync period to be used for a No Read condition. The absence of a sync signal results in operation similar to the Free Scan Operation described later.*

Sync Mode – Stationary Bar Codes

In this mode, a bar code(s) are placed in the beam and held in a known position. A sync input commands the SV Series to turn on the laser beam, perform a programmable number of scans, report the analyses and turn off the laser beam.

A ~SA communication sync command is the most common sync source in this mode. A rastering laser option is often used to analyze bar code area. **Note: The SV Series must be programmed for Picket Fence travel orientation in this mode if the bar codes are stationary when being scanned.**

No Sync – Free Scan Operation

In this mode, a sync signal is not used and the SV unit scans and analyzes bar codes at random as they pass through the laser beam. As stated in the Sync Input section, this mode is not recommended because it cannot report on missing or undetectable bar codes that can be caused by printer or other system component failures. This mode is most acceptable when the SV Series is used as a bar code decoder only.

It is recommended to use serial communications to a host in this mode in order for the host to determine missing codes.

If this mode is used, the SV Series can still detect many print errors because of its partial decode analysis capability. This algorithm can detect a bar code start or stop character and two adjacent characters. This part of a code is usually present in most print failure situations.

For maximum reliability for partial decode analysis, the bar code(s) being analyzed must be present in the laser beam for 10 scans (example: 100 milliseconds for SV units with 100 scans/analyses per second performance). To calculate bar code travel speed in this mode, see the Bar Code Travel Speed Considerations section. Calculate the maximum speed for the application per those instructions and then divide the speed by two for this application.

PARAMETERS ANALYZED

For each bar code scanned and analyzed, the SV Series performs practically all the ANSI, traditional and laser based verification methods documented in industry specifications. All analysis parameters for these methods are reported via serial communications (see Serial Port Transmission Format section) and most of the parameters can be used in any combination to activate the five ports. The analysis parameters performed are listed below in the same order of the standard transmission format as applicable.

Reference Decode (ANSI method parameter)
Decodability (ANSI method parameter)
Modulation (ANSI method parameter)
Defects (ANSI method parameter)
Edge Contrast (ANSI method parameter)
Rmin/Rmax (ANSI method parameter)
Symbol Contrast (ANSI method parameter)
PCS (Traditional method parameter)
Reflectance – Light (Traditional method parameter)
Reflectance – Dark (Traditional method parameter)
Ratio (Traditional method parameter)
Average Bar Deviation (Traditional method parameter)
Minimum Bar Deviation (Traditional method parameter)
Maximum Bar Deviation (Traditional method parameter)
Quiet Zone (Traditional method parameter)
X Dimension (Traditional method parameter)

Overall Symbol Grade (ANSI method parameter)
Bar Code Direction (scanner decoder function)
Symbology Type (scanner decoder function)
% Decode (multiple scanning parameter)
Global Threshold (ANSI method parameter)
Modulo Check Digits (mandatory symbology and optional application parameters)
Encoded Data (scanner decoder function)

SV COMMAND LANGUAGE

All commands to the verifier begin with a tilde, '~', followed by one or more alphanumeric characters. The '~' identifies the subsequent character string as a verifier command. The string is parsed from left to right. The first character after the '~' identifies the command category. Each command requires at least one additional character that identifies the particular command from that category. Some commands require additional data, e.g., a data value, or an option ID character, or a text string. These values are included at the end of the command string. The command string format is shown below. As each character is received by the SV unit, it echoes back the same character. Echo-back is used to determine when the verifier has completed the command action. The verifier is ready to receive the next command when the last character of the command is transmitted (echoed-back) to the host.

~CPx...

- ~ - indicates the start of a command string.
- C - a character that identifies the command Category
- P - a character that specifies the Particular command in the category
- x... - a number or text string (as necessary)

Data Match Commands – B

A '~' followed by a 'B' specifies a command from the Data Match category. All Data Match commands include a second alphabetic character that identifies the particular diagnostic command. The Data Match Commands are listed below.

An important consideration when using data match type commands is the data format. These commands incorporate a "scanner" philosophy rather than a "verifier" philosophy. A scanner philosophy is to report the data encoded in a symbol while a verifier philosophy is to report all symbol characters whether they include data or not. Symbol characters typically include stop character, start character, symbology mod check digit(s), internal control characters, etc. depending on the symbology type.

The data fields described in the B commands below include data characters only, therefore the ~B commands have a "scanner" philosophy. The one possible exception is in UPC or EAN symbols the symbology mod 10 check digit is also considered a data character.

~BCa##bc{...bbb...}{...mmm...}{...bbb...}... {etc. up to 32 characters max.}

Check for specific data

This command sets (enables) or clears (disables) one of 10 available data match arrays. All ten arrays may be active simultaneously. A data match error occurs if at least one array is active and the data scanned does not match the data programmed in the array. Each array can be up to 32 characters in length. Multiple portions of each array can be masked and the mask character is defined in the command. The data in the array must consist of printable ASCII characters with ASCII values less than 128. See the ~BU# command description for option to detect a Function 1 character in Code 128 symbols.

- ~BC - Data Match Command
- a - 1 digit. A number between 0 and 9. It identifies the data match array being programmed or cleared.
- ## - Number of data characters in the Data Match array. The value can be 01 through 32. A value of 00 clears (disables) this array.

- b - This character defines the fill character for masking purposes. This character cannot be a character to be matched in the match field mmm.
- c - This character defines the size of the data match field to be fixed (“f”) or variable (“v”). If variable, the data in the field is left justified in a 32 character possible field.
- ...bbb... - Fill characters prior to the Data Match text. These characters must match the character defined by b in the command.
- ...mmm... - Data Match Character Field. This can be from 1 to 32 characters. These define the exact characters that must be matched.
- ...bbb... - Fill characters after the Data Match text (if needed).

Note: Other Data Match Fields and Fill characters can follow for up to 32 characters total length.

Examples:

~BC005xfABCDE

- Data match array #0 with 5 characters of “ABCDE” of fixed length with ‘x’ as the ignore or fill character. In this case, the ‘x’ must be in the command, but is not used.

~BC210xfxxxABCDEXZ

- Data match array #2 with 10 characters of fixed length. ‘x’ as the ignore or fill character. The 4th through 8th characters must be ABCDE respectively and the 10th character must be a Z in a 10 character field for a data match.

~BC004xvx111

- Data match array #0 is defined as variable length, therefore can be up to 32 characters long. ‘x’ is the fill character. The second through 4th characters all must be 1 for a match

~BC000bc

- Disable Data match array #0. Any proper character as described above can be used for the b and c characters. The remainder of the array data is not required.

Note: In the above examples, the character ‘x’ (defined as the fill character) cannot be included in the portion of the bar code data that is programmed to be matched.

~ Brnbb{ .. + 0-9.. !)

Define increment or decrement data check

One array is available for checking a numeric (base 10) or alphanumeric (base 36) incrementing or decrementing field. The data field being checked must be fixed length. Portions of a field can be checked through masking. An initial (starting) value for the field may also be programmed in the array. Total field length can be up to 32 characters maximum. Characters analyzed can be numeric or alphanumeric (0-9, A-Z). This command can be used in conjunction with the ~BC command.

~B - Command initiation for checking an incrementing data field

r - Indicates incrementing (I) or decrementing (D) function

n - Required digit following ~Br. If set to a ‘0’ (zero), the check is performed for digits 0-9 only. If set to 1, the check is performed for alphanumeric characters 0-9, A-Z.

bb - Number of characters in array. A value of 00 clears (disables) this array.

...!!! - Mask characters for defining positions in the data field not being checked.

...+++ - Characters in the data field being checked. If + characters are used, this marks the field and defines its size. Maximum field lengths are 8 characters for numeric and 6 characters for alphanumeric. If a proper numeric or alphanumeric value is placed in the field, this additionally becomes the initial value expected on the first data scanned after a power-up or reset.

Incrementing Examples:

~BI010!!!!!!!+++

- Increment is to be done in the last three characters of the 10 character array.

~BI010!!!!!!!234

- Increment is to be done in the last three characters of the 10 character array. Initial value scanned must be 234.

~BI010!!!!!!!+++!!

- Increment is to be done in location 6 through 8 characters of the 10 character array.

Decrementing Examples:

~BD010!!!!!!!+++

- Decrement is to be done in the last three characters of the 10 character array.

~BD110!!!!!!!C34

- Decrement is to be done in the last three characters of the 10 character array. The initial value scanned must be C34 (base 36 alphanumeric field).

~BD010!!!!!!!+++!!

- Decrement is to be done in location 6 through 8 characters of the 10 character array.

~BI000 or ~BD000

- Disable the Increment/Decrement array. The remainder of the array data is not required.

~BU#

Allows data match command ~BC to detect a Code 128 Function 1 character

This allows a check to make sure function 1 characters (F1) are correctly placed in applications involving UCC/EAN 128 symbols. # = 0 or 1.

If ~BU0 is set - the ~BC command acts “normal” per the ~BC command description.

If ~BU1 set, if a right bracket character (]) character is set in the ~BC command data field, that will be used as a match for a Code 128 F1 character

The F1 character will be treated as a data character rather than a symbol character and therefore be included in the data match logic.

This also means that even if the special character is not included in the ~BC command, but ~BU1 is set, an F1 character in the symbol will still be checked as a data character, therefore any extra F1 character will cause a data match error.

Note: if ~OS1 is set, and ~BU1 is set, right bracket characters are stripped from the transmitted data. Therefore this application is not suitable when mixing UCC/EAN 128 codes and normal Code 128 codes that contain a right bracket character. Setting ~OS0 for all symbol characters in the transmission operates normally with either setting of ~BU#.

Relationship between ~BC and ~Br Commands

When programming both data match and increment/decrement arrays, the data match array(s) have higher priority. This is useful when analyzing a label containing more than one bar code, and one of the codes contains an incrementing or decrementing field. In this case, a data match array(s) can be used to match (or in this case – logically “mask”) the bar code(s) containing static data and the increment/decrement array can analyze the incrementing or decrementing bar code data.

~ BT

Lists all Data Match strings and Increment/Decrement fields.

Diagnostic Commands - D

A '~' followed by a 'D' specifies a command from the Diagnostic category. All Diagnostic commands include a second alphabetic character that identifies the particular diagnostic command. The Diagnostic Commands are listed below.

~DF

Get the Scan Rate

Possible returned frequency values are 270 through 800.

- 1) ~D
- 2) hexadecimal value '4' - identifies the beginning of the datapacket response
- 3) a data sequence that repeats the following format: a space, then three digits (a 'counts' value), then a '\r' character (carriage return) and a '\n' character (a line feed).
- 4) hexadecimal value '5' - identifies the end of the datapacket response
- 5) F - the last character of the sent command string

Example return using ScanVision:

Scan Rate: 400

~DN#

Inquire port activation data.

This command instructs the verifier to report all parameters of the event that caused this port to go active.

= 1 through 8 (port ID)

~DV

Inquire software version.

Commands the verifier to transmit the SV Series firmware version to the host in the following datapacket format:

- 1) ~D
- 2) hexadecimal value '4' - identifies the beginning of the datapacket response
- 3) The following character string between the quotes: 'Version: '
- 4) Five alphanumeric characters that specify the version number. They can include trailing spaces. (See example below.)
- 5) hexadecimal value '5' - identifies the end of the datapacket response
- 6) V

Example return using ScanVision:

Version: X327

~De#

Select reply format for ~HT command.

= values of 0 or 1.

= 0 sets the normal ~HT reply as shown in the ~HT command description.

= 1 sets an alternate ~HT command reply. Additional advanced command statuses are provided and all commands are listed in alphabetical order.

Hardware Configuration Commands - H

A '~', immediately followed by an 'H', specifies a command from the 'Hardware' category. All Hardware Commands require one additional character that identifies the particular Hardware Command. The Hardware Commands are listed below.

~HB#

Set the Baud Rate.

Possible values for # are:

1	(specifies 9600)	
2	(specifies 19200)	
3	(specifies 38400)	
4	(specifies 57600)	
5	(specifies 115200...	the default)

The default value is set at the factory (before shipping).

Returns the following sequence:

- 1) ~H
- 2) hexadecimal value '4' - identifies the beginning of the datapacket response.
- 3) Six hexadecimal digits (upper case) - the memory address
- 4) \r - carriage return character
- 5) \n - line feed character
- 6) hexadecimal value '5' - identifies the end of the datapacket response
- 7) B

Example return using ScanVision: (inputted ~HB5)

BAUD SET TO: 115200

~HL#

Select "Ladder" or "Picket Fence" bar code travel direction mode.

= 1 (Ladder)
0 (Picket Fence)

~HO#

Operational Mode

= 0 (inhibit output) Use this state only when downloading.
1 (moving bar codes mode) Use for normal operation.
2 (moving bar codes mode, fast code exit)
3 (reserved)
4 (stationary bar codes mode)

~HQ#

Transmission Mode

= 0 = Standard mode
1 - 9 = reserved

~HT

Display the verifier parameters

The format of the reply is when ~De0 is set: See ~De# command for an alternate reply choice.

- 1) **~H**
- 2) hexadecimal value '4' - identifies the beginning of the datapacket response.
- 3) A list of text strings like the one shown in the example. Each string is terminated by a two character sequence: '\r' (the carriage return character), '\n' (the line feed character).
- 4) hexadecimal value '5' - identifies the end of the datapacket response
- 5) **T**

Example: (The numbers of parameters reported varies with the commands included in the firmware revision)

```
~H
{hex 4}
[~HS###]SOS= 048
[~HP###]Beam Shift= 000 000
[c]HIGHcal= 085
[c]LOWcal= 002
[~Sh##]= 000
[~Sl##]= 000
[c]SCfact= 045
[c]min cal= 024
[~HB#]baud= 005
[~LL]smt_decode= 471
[~LM##]chars= 032
[~LN##]num_bc= 001
[~LZ##]num_bc_exact= 000
[~LR#]No_Read_Enable=000
[~LF##]I25_Mod10_Chk=040
[~HQ#]output_mode= 000
[~HO#]oper_mode= 001
[~LA##]ansi= 000
[~LS##]min_scn= 002
[~LT#]sync_in= 001
[~LP#]sync_pol= 001
[~LX#]sync_typ= 002
[~LV##]sync_md= 001
[~PO#]port_sel= 005
[PC#]port_clear_md= 000
[Pt##]port_time= 099
[~LD##] %dec= 000
[~PR####]PRST= 000200
[~HL#]ladder_code= 000
[~HJ####]ladd_start= 0800
[~HK####]ladd_end= 1600
[~HC####]ana_len= 2600
[~HG####]ana_lenh= 1300
[~HN####]pana_len= 1300
[~HU####]freq= 400
[~HV###]GTLA_len= 199
[~HY###]snoise= 070
[~HX###]dist= 078
[~H=#]dyn_out= 000
[~H!###]zone_tol= 450
[~H@##]gt_%= 050
```

```

[~SN###]#scans= 050
[~Lp#]part= 000
[~Lt#]itfp= 001
[DACs]= 175 156 255 255
[~LQ#]p_out= 000
[~Lw,d]def= 000 000
[~L*]pnet= 000
[~LC##]I25min= 002
[~H###]NTrys= 010
[~OS#]Data_Output= 000
[~Hs#]RunSpeed= 000
[~SS#####]CntlChars=013 010
{hex 5}
T

```

~Hdx01nnn

Sets scanner gain or offset.

x = value of 1 or 2. If =1, scanner gain is set. If = 2, scanner offset is set.

nnn = gain or offset setting.

For gain, the higher the value, the higher the gain. 225 is the max allowed value.

Example: ~Hd101195 sets the scanner gain setting to a value of 195.

For offset, the higher the value, the lower the offset.

Example: ~Hd201145 sets the scanner offset value to 145.

These commands are best used in conjunction with RJS ScanVision software. Please refer to the Setup Procedures Section in this guide for descriptions on the use of these commands.

~Hnx

Sets the number of consecutive scans that do not detect a bar code that cause a bar code to exit the beam and be reported.

x = values of 2, 3, 4 or 5. The normal setting is 5.

This command is best used in conjunction with the ~SB1 setting for single scan operation. Please see ~SBn command description.

~Hx

Saves the parameters to FLASH (non-volatile memory) from RAM.

~H#nn

Sets the number of signal transitions to search for finding a bar code symbol

nn = values of 10 through 99. This indicates the number of high to low transitions of the optical signal to search before ending a search for a bar code. High values of nn are useful when complex graphic fields or small fonts are closely adjacent to a bar code and therefore in the scan path. The higher the number, however, the greater chance the analysis rate will be lowered. For normal situations with minimum graphics in the same path as the bar code, a value of 10 is recommended (**~H#10.**)

Label Setup Commands - L

A '~' followed by an 'L' specifies a command from the Label Setup category. The next character identifies the particular Label Setup Command. In general, the commands in this category terminate with one or more numeric digits. The Label Setup Commands are listed below.

~LA##

Overall passing grade.

is the numeric grade value – 00 through 40. Example ~LA32 causes an ANSI Overall Symbol Grade of 3.1 or lower to set a failure condition.

~LC##

Minimum number of symbol characters to decode in an Interleaved 2 of 5 symbol.

This command sets the minimum number of symbol characters to be expected (## in the command, 01-16) by the Interleaved 2 of 5 decoder. This adds extra filtering in applications where I 2 of 5 symbols are used and there is a large amount of other graphics such as fonts in the scan path. Example: ~LC03 sets the unit to decode I 2 of 5 symbols (assuming the I 2 of 5 decoder is enabled) containing three or more symbol characters. *Note: each I 2 of 5 symbol character contains two data digits, therefore the symbol in the example must contain a minimum of six data digits to be decoded.*

~LD##

Passing percent decode.

This command sets the % decode threshold for a passing condition. If analyzing poorly printed symbols, it is recommended that partial decodes be enabled at the decoder level when this command is enabled. xx = failure threshold. Example ~LD75: if 74 % or less of scans on a code were not fully decoded, this sets a failure for this parameter.

~LE#

Exclude the Specified Symbology for a Label: ('#' identifies the excluded symbology:

- # = 1(UPC/EAN)
- 2(Code 39)
- 3(Code 128)
- 4(Interleaved 2 of 5)
- 5(Code 93)
- 6(Codabar.)

~LFxy

Analyze special subsymbology parameters

This command enables special subsymbology parameters within a symbology. This does not affect the automatic calculations and analyses for mandatory symbology check digits such as those required in Code 128, UPC/EAN and Code 93.

- x = symbology type 1(UPC/EAN)
- 2(Code 39)
- 3(Code 128)
- 4(Interleaved 2 of 5)
- 5(Code 93)
- 6(Codabar.)

y = subsymbology choice for a particular symbology. Current choices include:
0 = disabled (default condition)
1 = Mod 10 check digit for Interleaved 2 of 5

Note: additional subsymbology choices will be added as applications require. Contact RJS for details.

Example: ~LF41 = check mod 10 check digit in last location for any I 2 of 5 symbol analyzed

~LF40 = disable any subsymbology analysis for I 2 of 5 symbols

~LI#

Include the Specified Symbology for a Label: '#' identifies the included symbology:

- # = 1(UPC/EAN)
- 2(Code 39)
- 3(Code 128)
- 4(Interleaved 2 of 5)
- 5(Code 93)
- 6(Codabar.)

~LL

Report the Excluded Symbologies and the Included Symbologies Specified for all the Defined Bar Codes.

- 1) Hexadecimal value '4' - identifies the beginning of the datapacket response
- 2) The mode for each symbology is reported in a character string, which terminated with either 'IN' (for included) or 'EX' (for excluded) followed by a '\r' character (carriage return) and a '\n' character (a line feed). See the example below. The next two columns indicate statuses of the ~LM and ~LN commands respectively. (The ~LM command is not used in normal operation.)
- 3) Hexadecimal value '5' - identifies the end of the datapacket response
- 4) L - the last character of the sent command string

Example return using ScanVision:

```
1- UPC/EAN- IN
2- C39- IN
3- C128- IN
4- CITF- IN
5- C93- IN
6- CBAR- IN
min chars: 032
number bc: 099
L
```

~LN##

Set Minimum Number of Bar Codes Per Label (i.e., per sync period)

This command instructs the verifier on how many bar codes it is expected to read and analyze during a sync period. If the programmed number of codes is not read, a (robust) NO READ condition is internally flagged for communications or output port activation. Except for mode ~LV03, this command sets the minimum bar codes expected. Mode ~LV03 uses this value for the EXACT number of codes read during the sync interval. **Note:** See ~LZ## command for other options.

= 01 through 99

Default = 01.

~LN and ~LZ commands can be entered via bar codes to eliminate the need for a PC to program No Read conditions

- a. Bar codes embedded with a ~LN or ~LZ command can be entered by placing the bar code in the beam at any distance or angle where the READ led is on, then going through the same procedure as the calibration procedure.
- b. The settings are stored in temporary memory, therefore a power up will revert back to original settings in permanent memory.
- c. Unlike the calibration procedure, the laser beam will not turn off after the command is scanned, but, like the calibration procedure, the CAL LED will turn off.
- d. The format for the bar code command is;
 1. Code 39
 2. Data "RJS�xnn" where x is N or Z and nn is the 2 digit number in the command.
Example: RJS�N02 sets the ~LN02 command in temporary memory.
 3. Ratio and X dimension can be any value that can be scanned by the SV unit.

~LP#

Set Sync Polarity (See Sync Inputs Section for examples of sync input polarities.)

= 0 (falling edge of signal is active)

1 (rising edge of signal is active)

~LQ#

Enable or Disable Port Activations by Partial Decodes

- 0- Disable Port Activation by Partial Decodes
- 1- Enable Port Activation by Partial Decodes

~LR#

Enable or Disable No Read Transmission, or Alternate Data Transmission Formats

A No Read transmission message can be sent via the serial port if the SV unit is receiving sync inputs. See the Serial Port Transmission Format Section for details. Fields y, M and N (data positions 52 through 55) set to 0 indicate a No Read condition.

= 1, enables the No Read message to be transmitted

= 0, disables the No Read transmission.

The transmission is available in any output interface mode that includes a no read condition. The transmission data format enabled (~OS#) does not affect the format of the No Read transmission.

Alternate data formats can also be transmitted using the ~LR# command.

= 2, disables all data transmissions. The exceptions are ~SA and ~SY will cause a “normal” transmission if a bar code is in the laser beam when the command is received. This allows bar codes to be reported to ScanVision during setup. A No Read transmission is not available with this setting.

= 3, causes the SV unit to transmit bar code data only without the 88 byte field used to indicate all quality parameters. The data has no framing. The data format is determined by the state of the ~OS# command (data or all symbol characters). ~SA and ~SY will cause a “normal” transmission including the 88 byte field of verification analyses if a bar code is in the laser beam when the command is received. This allows bar codes to be reported to ScanVision during setup. A No Read transmission is not available with this setting.

= 4, is identical to ~LR3 with the exception that after the data characters a carriage return character is transmitted followed by a line feed character.

= 5, is similar to ~LR3 in that it causes the SV Unit to transmit bar code data only in the format set by the ~OS# command. The data is framed by characters set by the ~SSbbbeee command. Commands ~SA and ~SY will allow transmission of the “normal” format including the 88 byte field of verification analyses, but the transmission will also be framed with the characters set by the ~SSbbbeee command. Therefore it may not be compatible with setup with ScanVision. A No Read transmission is not available with this setting.

= 6, causes the SV unit to transmit bar code data only, without the 88 byte field used to indicate all quality parameters. The data has no framing. The data format is determined by the state of the ~OS# command (data or all symbol characters). ~SA and ~SY will cause a “normal” transmission including the 88 byte field of verification analyses if a bar code is in the laser beam when the command is received. This allows bar codes to be reported to ScanVision during setup. With this setting, a No Read transmits the string “No Read” instead of the No Read analysis record.

= 7, is identical to ~LR3 with the exception that after the data characters a carriage return character is transmitted followed by a line feed character. With this setting, a No Read transmits the string “ No Read” instead of the No Read analysis record.

= 8, is similar to ~LR3 in that it causes the SV Unit to transmit bar code data only in the format set by the ~OS# command. The data is framed by characters set by the ~SSbbbeee command. Commands ~SA and ~SY will allow transmission of the “normal” format including the 88 byte field of verification analyses, but the transmission will also be framed with the characters set by the ~SSbbbeee command. Therefore, it may not be compatible in setup with ScanVision. With this setting, a No Read transmits the string “No Read” instead of the No Read analysis record.

~LS##

Set minimum number of scans for valid read

= 02 – 99 (See ~SBn command for ##=01; single scan mode)

This command sets the minimum number of times a full decode must be achieved on a symbol in order to be a valid read. The system acts slightly differently, depending on what operation mode is set – ~HO1 or ~HO2.

With ~HO1 enabled, if the minimum number of full decodes is not accomplished, a No Read condition is set, even though the bar code is read, analyzed and reported. The report includes a No read status indication. With ~HO2 enabled, if the minimum number of full decodes is not accomplished, the code is not recognized nor reported. This essentially creates a No Read condition when a sync input is being received.

When used in conjunction with the ~LDxx command, the ~LS## command can create a powerful area check of a symbol.

~LT#

Sync Input Source

Isolated Input (Pins 1(+), 2(-)) = 0
TTL Input (Pin 4) = 1
Communication Sync = 2

~LV##

Output Interface Mode

= 00 - 99:

This command sets the output interface mode of the unit. Modes have fixed port activation logic defined by specific applications. Some activation parameters are programmable. Custom modes are available – contact RJS technical Support. Modes included in standard SV Series are described in the Output Interface Modes Descriptions Section. Example: ~LV01 sets mode 01.

~LX#

Sync Type

- 0 - Envelope sync
- 1 - Edge sync
- 2 - Envelope sync w/beam control – leading edge turns on laser, trailing edge turns off laser
Note: ~LP# sets polarity for Modes 2, 19 and 20 when ~LX2 is set
- 3 – Edge sync w/beam control – edge turns on beam, bar code exiting beam turns beam off
Note: Use ~LS02 setting for sync type ~LX3

~LZ##

Set Exact Number of Codes per Label (i.e., per sync period)

This command sets the exact number of codes to be read during a sync period. ## = the number of codes. For example: ~LZ02 causes a No Read condition to be set if exactly 2 bar codes are not fully decoded during a sync interval. This command can also be entered by scanning a bar code. See details in the ~LN command description.

This command overrides the ~LN## command if the number of codes set does not = 00. If ~LZ## is set to ~LZ00, the ~LN## command takes precedence.

~Lp#

Turn partials on and off at the decoder level for all symbologies.

- 0- Disable
- 1- Enable

~Lt#

Turn partials on and off at the decoder level for Interleaved 2 of 5 codes only.

0 - Disable

1 - Enable

Output Mode Selection Commands - O

A '~' followed by an 'O' specifies a command from the Output Mode Selection category. These commands include one additional character that identifies the particular Output Mode Command. The Output Mode Selection Commands are listed below.

~OL##

Set an LED on/off. (Does not over-ride normal operation; recommended for use as diagnostic in Mode 0 (~LV00) only)

First '#' - Possible values are '1','2'. Identifies the LED.

Second # - Possible values are '1' (on), '0' (off).

~OP##

Set a PORT on or off. (Does not over-ride normal operation; recommended for use as diagnostic in Mode 0 (~LV00) only)

First # - Possible values are '1','2','3','4','5'. Identifies the port.

Second # - Possible values are '1' (on), '0' (off).

~OS#

Set Transmission Data Format

This command is affective only if the standard transmission mode is enabled via the ~HQ0 command.

0 = Standard transmission format as described in the Serial Port Transmission Format Section

1 =Standard transmission format modified; analysis parameters a through N included, but encoded data is formatted as data characters only rather than all symbol characters. The data consists only of printable ASCII characters and does not include any mandatory symbol characters such as stop, start and symbol mod check characters. One exception is in UPC/EAN codes, the mod 10 check digit is included.

Output Port Setup Commands - P

A '~' immediately followed by a 'P' specifies a command from the Output Port Setup category.

***NOTE:** The following descriptions of the ~PB and ~PP commands imply all ports are individually programmable. All SV port logic is currently programmed via the Output Interface Mode command ~LV##. See the Output Interface Mode Descriptions section for details of port logic. The ~PB and ~PP commands are used to program activation parameters available in the mode settings and are limited to the case where the value of the variable p in the command is always a value of 8. "Port 8" is a general port used for internal purposes. This structure reserves individual port programming to be available in the future.*

Many of the activation parameters are ANSI method calculations. Please see the ANSI Parameter Grade Thresholds Section for details on the values of these parameters.

~PBpīīaaabbb

Port barcode decision block parameters.

pīīaaabbb = Nine decimal digits representing:

Port- p

ID- ii (See Table of Analysis Parameters for ID descriptions)

Low passing threshold- A (aaa)

High passing threshold- B (bbb)

Values for aaa and bbb can be found in the following table:

Values “A” and “B” determine the passing thresholds. If the measured parameter is less than A or greater than B the relevant error flag would be set.

See **Output Interface Modes Descriptions Section** for ~PB command examples

Table of Analysis Parameters

IDs	Analysis Parameters	Low	High	Units	Low Value	High Value
01	Overall Grade	0.0	4.0	Grade	000	040
02	Decodability	0	100	%	000	100
03	Modulation	0	100	%	000	100
04	Symbol Contrast	0	100	%	000	100
05	EC min	0	100	%	000	100
06	Defects	0	100	%	000	100
07	Rmin/Rmax	0	100	%	000	100
08	Rw	0	100	%	000	100
09	Rb	0	100	%	000	100
10	PCS	0	100	%	000	100
11	Z within TOL of VAL	1	255	Mils	001	255
12	AVG BWD	-100	100	% of X	000*	200*
13	MIN BWD	-100	100	% of X	000*	200*
14	MAX BWD	-100	100	% of X	000*	200*
15	Ratio	1.8	8.0	Ratio	018	080
16	QZ (Percent good QZ)	0	100	%	000	100
17	ICG	0.1	8.0	X-dim	001	080
18	Application Mod CHK	NA	NA	Flag	000	000
19	Min Scans	2	200	Scans	002	200
20	Min Chars	1	64	#	001	064
21	Percent Decode	0	100	%	000	100
22	Ref. Decode	NA	NA	Flag	000	001
23	Character Format	NA	NA	Flag	000	001
24	Partial Decode	NA	NA	Flag	000	001
25	Data Match	NA	NA	Flag	000	001
26	Illegal Position	NA	NA	Flag	000	001

*The data format for negative numbers ranging from -100 to -1 is 0 to 99. For example: -100=0; -95=5; -10=90; 0=100; 25=125; 95=195; 100=200

~PPpiiiaa

Port action parameters.

piiiaa = Six decimal digits representing:

Port- p

ID- ii (See Table of Action Parameters for description of ID)

Value of action- aaa

Table of Action Parameters

ID S	Description	Low Value	High Value
01	Pulse width (0.1s to 10.0s; > 10.0= latch)	000	255
02	Active State high or low	000 (active low)	001
03	Set port on Good/Bad Evaluation	000(Bad)	001(Good)

~PLpii

List all Port setup parameters. (Parameters are set by the ~PB command.)

pii= Three decimal digits representing:

Port- p

ID- ii

~PT#

Show <Port 1 to 8> status and all the Port Parameters (Parameters are set by the ~PB command.)

Transmission is in the following format for command ~PT1:

- 1) ~PT
- 2) hexadecimal value '4' - identifies the beginning of the datapacket response.
- 3) A list of text strings like the one shown in the example. Each string is terminated by a two character sequence: '\r' (the carriage return character), '\n' (the line feed character).
- 4) hexadecimal value '5' - identifies the end of the datapacket response
- 5) 1

Example return using Scanvision:

```
Port Status:
Global HW: 001
Global SW MIRR: 001
PORT STATE: 000
PASS/FAIL PARAMETERS:
001 - 255 255
002 - 037 100
003 - 255 255
004 - 000 100
005 - 255 255
006 - 021 000
007 - 255 255
008 - 255 255
009 - 255 255
010 - 255 255
011 - 010 050
012 - 255 255
013 - 255 255
014 - 255 255
015 - 018 000
016 - 050 100
017 - 255 255
018 - 255 255
019 - 255 255
020 - 255 255
021 - 255 255
022 - 255 255
023 - 255 255
024 - 255 255
025 - 255 255
026 - 255 255
```

~PR####

Port/LED reset state

= four hexadecimal digits

Each output port and led is represented by a binary digit in the four hexadecimal digits as follows:

<u>Indicator</u>	<u>Digit value</u>
Power indicator	0x0001
Read LED	0x0002
LED1	0x0004
LED2	0x0008
Output Port 1	0x0010
Output Port 2	0x0020
Output Port 3	0x0040
Output Port 4	0x0080
Output Port 5	0x0100
* Sync Indicator	0x0200

* Inverted logic

- Except for the sync indicator, if a bit is clear, the inactive state of the port is OFF. Example:
~PR0210 = sync indicator goes “ON” when a sync is detected and Port 1 goes “OFF” when activated. All other ports go “ON” when activated.

~Px

Save the new port configuration by writing it onto the flash.

~PY

Cancel the current port setup (restore the old Port configuration by getting the old values from the flash).

~PZpii

List the parameter action. (Parameter actions are set by the ~PP command.)

Port- p

ID- ii

System Control Commands - S

A ‘~’ followed by an ‘S’ specifies a command from the System Control category. These commands include one additional character that identifies the particular System Control Command. The System Control Commands are listed below.

~SA

Software sync for communication output mode #4 – Commanded Read Mode (~HO4).

~SBn

Normal or Single Scan Operation

When n=0, normal scanning is enabled where a code must be scanned 2 out of 3 times in order to be detected.

When n=1, a single scan of can be used to capture and analyze a bar code, enabling bar codes to be analyzed while traveling through the laser beam at high speeds.

The major trade-off to the single scan feature is only one bar code at a time can be analyzed in the beam vs. up to 4 codes in picket fence mode in the standard system. The major disadvantage to this method in cases where only a single scan is used for evaluation of a bar code is there is a higher probability that the analyses may not be accurate because part of the scan could be at the upper or lower edges of one or more of the elements in the code. Therefore if most of the analyses are being calculated with a single scan, this type of operation is recommended for measuring print trends in high volume, high speed applications where some small percentage of analyses that randomly indicate an unusual low grade can be filtered out.

In the case the bar code is in the laser beam for more than a single scan, all the scans gathered are averaged in the symbol analysis just like standard SV operation.

The special single scan operation is enabled only in Ladder Orientation mode. Picket fence Orientation mode operation is not affected. The travel direction of the codes can be either picket fence or ladder. The reason for using ladder mode is it limits the number of codes that can be simultaneously analyzed in the beam to a single code.

How to Set Up Single Scan Operation

Three commands that set up the operation are ~SB1 and ~LS01 and ~Hnx (x can be 2, 3, 4, or 5). The SV must also be placed in "Ladder" mode and the code must be in the ladder zone to be scanned and analyzed.

~SB1 (~SB0 is the normal setting) enables the system to let the initial scan of a code pass to the analysis algorithms rather than wait for one of the next two scans to be a duplicate before the code is allowed to be analyzed.

NOTE: The ~SB1 setting may not update the horizontal bar code position in the report transmission. Therefore if the horizontal position is needed during setup, set ~SB0 temporarily to see the position, then set ~SB1 for 1 scan operation.

~LS01 allows the initial scan to be reported as a 1 scan average in case the code leaves the beam before a second scan is detected.

~Hnx is a command that programs the number of consecutive scans that do not detect a bar code that cause the code to exit the beam and be reported. The standard system operation is fixed at 5. ~Hnx can be programmed for 2, 3, 4, or 5 scans. A lower number will allow a higher duty cycle, but it may also be less stable if a code is static in the laser beam, therefore causing multiple reports. **Note:** Especially when setting up with a static code in the beam, or operating in picket fence orientation, make sure the code passes through the programmed ladder zone.

Checking SV Status with ~HT

The normal way of checking system status is with the ~HT command. The newer commands ~SB and ~Hn are not displayed with the standard ~HT command. In order to display the additional commands, set command ~De1 to allow the alternate ~HT reply.

When using ScanVision menus to program SV parameters, set ~De0 for normal ~HT reply or an error message may be displayed.

~SC

Execute the calibration procedure.

The SV unit will respond to this command as follows:

CP505050 will be transmitted if the calibration is successful.

CF000000 will be transmitted if the calibration was unsuccessful

~Sc (lower case c)

Set Scanner Gain and Offset for symbol that is in the laser beam

This command automatically sets the scanner gain and offset to a bar code that is in the laser beam. Place the SV unit in moving codes mode to use this command. In some cases where more than two reflectance levels are in the beam (caused by color graphics, etc.), this command will be unsuccessful. In those instances, use the ~Hd commands to set scanner gain and offset.

~SD

Disable Verification

This command turns the laser beam off.

~SE

Enable Verification

This command turns the laser beam on.

~SK#

Communication Sync

A sync command sent via serial communications can be used similar to an external sync input to analyze a no read condition. In previous versions of SV firmware the only way to create a no read transmission or no read control output from an SV unit is by detecting an external sync through inputs on pin 1,2 (Isolated) or on pin 4 (ttl) of the Power I/O connector.

= 0 or 1. Details of how the values are used in conjunction with other commands as follows;;

1. Command ~LT# includes an ~LT2 choice to allow ~SK# as the sync input
2. ~SK# will be received but not cause any action if either ~LT0 or ~LT1 is set.
3. An external sync input will not be recognized if ~LT2 is set
4. Receipt of ~SK# command will be identical to detecting a hardware sync input
5. After receiving the ~SK# command, the SV unit will operate per settings of the various commands related to sync inputs - ~LR#, ~LV#
6. ~LP0 must be set when using any Output Interface Mode except 2 and 19
7. ~LP1 must be set if using Output Interface Mode 2 or 19
8. ~LX0, ~LX1, ~LX2 or ~LX3 can be used with any Output Interface Mode except 2 and 19
9. ~LX0 must be set if using Output Interface Modes 2 or 19

Operation Description

1. If ~LX0 or ~LX2 (any envelope sync mode) is enabled
 - a. Receipt of ~SK1 will be the leading edge of the envelope sync
 - b. The end of the envelope sync will occur when ~SK0 is received
 - c. After ~SK1 is received, any additional ~SK1 received will be ignored until a ~SK0 is received
 - d. After ~SK0 is received, any additional ~SK0 will be ignored until an ~SK1 is received
2. If ~LX1 or ~LX3 (any edge sync mode) is enabled
 - a. Receipt of any ~SK0 will be ignored
 - b. Receipt of any ~SK1 will be the edge sync input

Comments

1. Recognition and response of the communication sync commands may be slower than a hardware sync (13 ms)

~SN###

Set the number of scans for Software Commanded Read Mode.

- The number of scans up to 200.

~SQ

Raster Check.

This command shows beams for all eight polygon facets for 4 seconds, then shows a beam for one facet for 4 seconds. Ideally, the beam widths will look identical in non-raster type scanners. Acceptable difference in most cases is 1/16th inch.

~SR

Reset the System.

This re-initialization procedure recalls all of the current setup parameters from the flash.

~SSbbbeee

Program the start and end characters in a transmission

bbb = decimal value of the ASCII character that indicates the beginning of a transmission.

eee = decimal value of the ASCII character that indicates the end of a transmission.

Allowed values for bbb and eee are 001 through 127.

Example ~SS083069 causes an S to be the beginning character and an E to be the ending character of a data transmission. This command applies only when the standard transmission mode is enabled (~HQ0.) **The command ~SS013010 must be used when operating with RJS ScanVision software.**

~SY

Software Sync for communication output modes #1 and #2 (~HO1, ~HO2); trigger a sync response from the verifier, and enable the verifier

~Sh##

Set the high target reflectance value for calibration.

- The high target reflectance value (70 to 99).

This sets a new high reflectance target value for a calibration symbol.

To use the target values encoded in the calibration symbol set this value to 00.

~Sl##

Set the low target reflectance value for calibration.

- The low target reflectance value (1 to 20).

This sets a new low reflectance target value for a calibration symbol.

To use the target values encoded in the calibration symbol set this value to 00.

~Ssxy

Program header and trailer characters in a standard transmission format.

This command is similar to ~SS, but allows a programmable number of characters that begin and end the standard transmission, where ~SS has a fixed single character for both start and end of the transmission.

x = number of characters in the header. Allowed values are 0,1,...9 therefore up to nine header characters are available.

y = number of characters in the trailer. Allowed values are 0,1,2 therefore up to two trailer characters are available.

If either x or y are not 0, then additional 3 digit fields indicating the decimal value of the ASCII character transmitted must be added to the command for each character placement indicated by the x and y settings. Allowed values are 001 through 255.

If both x and y are 0, then the ~SS command settings are used for header and trailer characters.

The ~Ssxy command is basically an override to the ~SS command and obeys all current logic involving the ~SS command in conjunction with other command settings. Therefore ~LR0 or ~LR1 must be set for the transmission format to be valid for all transmissions.

Any other values of ~LR override the transmission format with the format defined by that particular ~LR setting.

Data Transmission Example 1

If ~Ss00 is set, ~LR3 is set and SV is in moving codes mode, if ~SY is received the transmission format sent will be sent according to the ~SS command settings.

Data Transmission Example 2

If ~Ssxy is programmed so x or y does not equal zero, in the case of Data Transmission Example 1 above, the transmission format will be sent according to the ~Ssxy command setting.

~Ssxy Command Example 1;

~Ss32048049112013010

~Ss = the command header

x = 3 which means there will be three header characters transmitted

y = 2 which means there will be 2 trailer characters transmitted

048 = decimal value for ASCII character 0 which will be the first header character transmitted

049 = decimal value of ASCII character 1 which will be the second header character sent

112 = decimal value for ASCII character p which will be the third header character (and final) sent

013 = decimal value for ASCII character CR which will be the first trailer character sent

010 = decimal value of ASCII character LF which will be second (and final) trailer character sent

~Ssxy Command Example 2;

~Ss11080086

One header character P will be sent and one trailer character V will be sent

~Stx

Program Command Indicator Header

This command programs the indicator character from a pre-determined set of available characters.

x – the value of this character is used for selecting the command indicator. Available indicators are ASCII characters that are not part of any standard SV command syntax in order to be secure. Allowed values of x are 0,1, ..9. Indicator characters available are below;

~St0 = ~ (system default) ASCII decimal value of 126

~St1 = : ASCII decimal value of 58

~St2 = ; ASCII decimal value of 59

~St3 = (ASCII decimal value of 40

~St4 =) ASCII decimal value of 41

~St5 = [ASCII decimal value of 91

~St6 =] ASCII decimal value of 93

~St7 = { ASCII decimal value of 123

~St8 = } ASCII decimal value of 125

~St9 = ^ ASCII decimal value of 94

~Stx Command Example - ~St5

Valid command syntax is [LV00 instead of the default ~LV00

OUTPUT INTERFACE MODES DESCRIPTIONS

Output interface modes are used to set the SV Series for particular ways to activate output ports. The mode is set via the `~LV##` command. The following list describes the standard output interface modes available in SV firmware versions x270 and higher. Each description includes the commands for programming the particular parameters that can activate the proper ports for that mode. Custom modes are available – contact RJS Technical Support.

After programming the SV unit for the desired port activation parameters, it is recommended to review them. When using ScanVision, this can be done via the Transmit SV Commands Window by sending the `~HT` command to review all scanner settings, and sending the `~PT8` command to review all quality parameter failure threshold settings.

Mode 00 (~LV00)

This mode does not activate output ports. Only the serial communications port is active.

Mode 01 (~LV01)

A. Mode 01 I/O operation

1. System will operate in Edge Sync or Envelope sync mode (`~LX#`)
2. Sync polarity programmable (`~LP#`)
3. Use `~PR0210` for proper port initialization.
4. Port 1 will go active OFF (no current) on an error condition.
5. Port 2 will go active ON (sink current) on an error condition.
6. Pushing the reset button or power re-cycle will place Ports 1 and 2 in their inactive states and reset the # codes per sync counter.
7. Error conditions available are:
 - a. Partial Read (Programmable, `~LQ#`, `~Lp#`)
 - b. % decode (Programmable, `~LD##`)
 - c. Bad Quiet Zone (`~PB816xxx100`)
 - d. ANSI Defects grade (Programmable, `~PB806xxx000`)
 - e. ANSI Decodability (Programmable, `~PB802xxx100`)
 - f. Symbol Contrast grade (Programmable, `~PB804xxx100`)
 - g. No Read (if sync is received)
 - h. Number of codes per sync programmable (`~LN##`, `~LZ##`)
 - i. Overall ANSI Grade (Programmable, `~LAXx`)
 - j. Symbology modulo check digit

B. Mode 01 LED Operation

1. LED1 will turn on if Outputs 1 and 2 go active due to ANSI, contrast, or quiet zone failure
2. LED2 will turn on if Outputs 1 and 2 go active due to a partial or no read condition

Note; Both LEDs can be on in cases where multiple bar codes are analyzed in a sync period.

C. SV Commands Important to Mode 01

This system is operating in a “mode” rather than fully programmable logic. The port activation parameters are programmable via the `~PB8` rather than `~PB1`, `~PB2`, etc. for each individual port. Other commands, such as mode commands are also available. The commands most useful for this system application are described below.

`~LV01`

This command sets this mode of operation.

`~Lp0`

This command turns off all partial decode logic at the decoder level

~Lp1

This command turns on partial decode logic at the decoder level

~LQ1

This command allows partial decodes to activate the output ports

~LQ0

This command disables partial decodes to activate output ports.

NOTE: In SV firmware versions x238 and lower, ~LQ commands are not implemented and the command ~HQ1 must be used to disable partial decodes from activating ports. In this case the standard data transmission format is modified and ScanVision will not display data characters correctly.

~LDxx

This command sets the % decode threshold for a passing condition. If analyzing poorly printed symbols, it is recommended that partial decodes be enabled at the decoder level when this command is enabled.

xx = failure threshold. Example ~LD75: if 74 % or less of scans on a code were not fully decoded, this sets a failure for this parameter.

~PB816xxx100

This command sets the minimum percent of scans on a code which calculate good quiet zones to determine an acceptable quiet zone analysis. The field xxx is the minimum passing threshold. Example: if xxx = 030, a minimum of 30% of all fully decoded scans on a code must calculate a good quiet zone, or a failure condition is set for this parameter.

~PB806xxx000

This command sets the threshold for the ANSI Defects calculation on a code to set a failure condition. The field xxx is the passing threshold for the calculation. For example: if xxx = 025, a Defects analysis of 26% or higher will cause a failure condition for this parameter.

~PB802xxx100

This command sets the threshold for the ANSI Decodability calculation on a code to set a failure condition. The field xxx is the passing threshold for the calculation. For example: if xxx = 037, a Decodability analysis of 36% or lower will cause a failure condition for this parameter.

~PB804xxx100

This command sets the threshold for the ANSI Symbol Contrast calculation on a code to set a failure condition. The field xxx is the passing threshold for the calculation. For example: if xxx = 020, a Symbol Contrast analysis of 19% or lower will cause a failure condition for this parameter.

~LN##

This command sets the minimum number of codes to be read during a sync period. ## = the number of codes. For example: ~LN02 causes a No Read condition to be set if less than 2 bar codes are fully decoded during a sync interval.

~LZ##

This command sets the exact number of codes to be read during a sync period. ## = the number of codes. For example: ~LZ02 causes a No Read condition to be set if exactly 2 bar codes are not fully decoded during a sync interval.

This command overrides the ~LN## command if the number of codes set does not = 00. If ~LZ## is set to ~LZ00, the ~LN## command takes precedence.

~L A_{xx}

This command sets the passing threshold for the Overall ANSI method Symbol Grade. For example: ~LA28 causes an Overall Symbol Grade of 2.7 or lower calculated for the code analyzed to set a failure condition for this parameter.

~H x

This command stores all parameters into non-volatile memory. This command should be the last command sent after parameters are programmed via the above commands.

Mode 02 (~LV02)

A. Mode 02 I/O operation

1. Envelope type sync input on pin 4
2. Port 3: per sync type. The state of this output must be stable within 12.5 milliseconds after the sync input goes low (trailing edge.) Typical time for stability will be less than 7.5 milliseconds if the sync is received when a bar code or complex graphic is not in the beam. The port shall go active (sink current) for the following conditions;
 - a. ANSI Defects grade programmable (~PB806xxx000)
 - b. ANSI Decodability grade programmable (~PB802xxx100)
 - c. Overall ANSI Grade (Programmable, ~L A_{xx})
 - d. Bad quiet zone (~PB816xxx000)
 - e. No Read (if sync is received)
 - f. Partial decodes and % decode logic programmable (~L $p_{\#}$, ~L $Q_{\#}$)
 - g. Number of codes per sync programmable (~LN##, ~LZ##)
 - h. Symbology modulo check digit
3. Sync polarity - Leading edge high going; time between trailing (low going) edge to leading edge - 12.5 milliseconds minimum
4. Port 1; acts as strobe (signal ensuring Port 3 condition is stable) in response to trailing edge of sync input. This signal will go “on” (sink current) between 20 and 100 microseconds after Port 3 condition is stable.
5. Ports 1 and 3 will go high (no current) within 12.5 milliseconds after the sync input goes high (leading edge).
6. Use ~PR0200 for proper port initialization.

B. Mode 02 LED Operation

1. LED1 will turn on if Port 3 goes active due to ANSI or quiet zone failures
2. LED2 will turn on if Port 3 goes active due to a no read or partial condition
3. The leading edge of a sync input will turn LEDS 1 and 2 OFF.

C. SV Commands Important to Mode 02

This system is operating in a “mode” rather than fully programmable logic. The port activation parameters are programmable via the ~PB8 rather than ~PB1, ~PB2, etc. for each individual port. Other commands, such as mode commands are also available. The commands most useful for this system application are described below.

~LV02

This command sets this mode of operation.

~L p_0

This command turns off all partial decode logic at the decoder level

~L p_1

This command turns on partial decode logic at the decoder level

~LQ1

This command allows partial decodes to activate the output ports

~LQ0

This command disables partial decodes to activate output ports

NOTE: In SV firmware versions x238 and lower, ~LQ commands are not implemented and the command ~HQ1 must be used to disable partial decodes from activating ports. In this case the standard data transmission format is modified and ScanVision will not display data characters correctly.

~LDxx

This command sets the % decode threshold for a passing condition. If analyzing poorly printed symbols, it is recommended that partial decodes be enabled at the decoder level when this command is enabled.

xx = failure threshold. Example ~LD75: if 74 % or less of scans on a code were not fully decoded, this sets a failure for this parameter.

~PB816xxx100

This command sets the minimum percent of scans on a code, which calculate good quiet zones to determine an acceptable quiet zone analysis. The field xxx is the minimum passing threshold. Example: if xxx = 030, a minimum of 30% of all fully decoded scans on a code must calculate a good quiet zone, or a failure condition is set for this parameter.

~PB806xxx000

This command sets the threshold for the ANSI Defects calculation on a code to set a failure condition. The field xxx is the passing threshold for the calculation. For example: if xxx = 025, a Defects analysis of 26% or higher will cause a failure condition for this parameter.

~PB802xxx100

This command sets the threshold for the ANSI Decodability calculation on a code to set a failure condition. The field xxx is the passing threshold for the calculation. For example: if xxx = 037, a Decodability analysis of 36% or lower will cause a failure condition for this parameter.

~LAXx

This command sets the passing threshold for the Overall ANSI method Symbol Grade. For example:

~LA28 causes an Overall Symbol Grade of 2.7 or lower calculated for the code analyzed to set a failure condition for this parameter.

~LN##

This command sets the minimum number of codes to be read during a sync period. ## = the number of codes. For example: ~LN02 causes a No Read condition to be set if less than 2 bar codes are fully decoded during a sync interval.

~LZ##

This command sets the exact number of codes to be read during a sync period. ## = the number of codes. For example: ~LZ02 causes a No Read condition to be set if exactly 2 bar codes are not fully decoded during a sync interval.

This command overrides the ~LN## command if the number of codes set does not = 00. If ~LZ## is set to ~LZ00, the ~LN## command takes precedence.

~Hx

This command stores all parameters into non-volatile memory. This command should be the last command sent after parameters are programmed via the above commands.

Mode 03 (~LV03)

This mode is identical to Mode 01 with the exception of the meaning of the ~LN command:

~LN##

This command sets the **exact** number of codes to be read during a sync period. ## = the number of codes. For example: ~LN02 causes a No Read condition to be set if less or more than 2 bar codes are fully decoded during a sync interval. (This system is using edge sync mode, therefore a sync interval is the time between sync inputs.) ~LN00 disables a no read condition.

Mode 12 (~LV12)

A. Mode 12 I/O operation

1. System will operate Envelope or Edge sync mode (~LX#)
2. Sync polarity – programmable (~LP#)
3. Use ~**PR0210** for proper port initialization.
4. Port 1 will go active OFF (no current) on an error condition.
5. Port 2 will go active ON (sink current) on an error condition.
6. Port 3 will operate in per analysis pulse mode. Active polarity ON (sink current), approximately 500 millisecond duration. Port 3 will activate (pulse) on an error condition.
7. Port 4 will operate in per analysis pulse mode. Active polarity ON (sink current), approximately 50 millisecond duration. Port 4 will activate (pulse) on an error condition.
8. Pushing the reset button or power re-cycle will place Ports 1- 4 in their inactive states.
9. Error conditions available are:
 - a. Partial Read (~Lp#, ~LQ#)
 - b. % decode programmable, (~LD##)
 - c. Bad Quiet Zone (~PB816xxx100)
 - d. ANSI Defects grade programmable (~PB806xxx000)
 - e. ANSI Decodability grade programmable (~PB802xxx100)
 - f. Symbol Contrast grade programmable (~PB804xxx100)
 - g. No Read (if edge sync is received)
 - h. Number of codes per sync programmable (~LN##, ~LZ##)
 - i. Overall ANSI Grade (Programmable, ~LAXx)
 - j. Symbology modulo check digit

B. Mode 12 LED Operation

1. LED1 will turn on if Ports 1-4 go active due to ANSI, contrast, or quiet zone failure
2. LED2 will turn on if Ports 1-4 go active due to a partial or no read condition

Note; Both LEDs can be on in cases where multiple bar codes are analyzed in a sync period.

C. SV Commands Important to Mode 12

This system is operating in a “mode” rather than fully programmable logic. The port activation parameters are programmable via the ~PB8 rather than ~PB1, ~PB2, etc. for each individual port. Other commands, such as mode commands are also available. The commands most useful for this system application are described below.

~LV12

This command sets this mode of operation.

~Lp0

This command turns off all partial decode logic at the decoder level

~Lp1

This command turns on partial decode logic at the decoder level

~LQ1

This command allows partial decodes to activate the output ports

~LQ0

This command disables partial decodes to activate output ports.

NOTE: In SV firmware versions x238 and lower, ~LQ commands are not implemented and the command ~HQ1 must be used to disable partial decodes from activating ports. In this case the standard data transmission format is modified and ScanVision will not display data characters correctly.

~LDxx

This command sets the % decode threshold for a passing condition. If analyzing poorly printed symbols, it is recommended that partial decodes be enabled at the decoder level when this command is enabled.

xx = failure threshold. Example ~LD75: if 74 % or less of scans on a code were not fully decoded, this sets a failure for this parameter.

~PB816xxx100

This command sets the minimum percent of scans on a code which calculate good quiet zones to determine an acceptable quiet zone analysis. The field xxx is the minimum passing threshold. Example: if xxx = 030, a minimum of 30% of all fully decoded scans on a code must calculate a good quiet zone, or a failure condition is set for this parameter.

~PB806xxx000

This command sets the threshold for the ANSI Defects calculation on a code to set a failure condition. The field xxx is the passing threshold for the calculation. For example: if xxx = 025, a Defects analysis of 26% or higher will cause a failure condition for this parameter.

~PB802xxx100

This command sets the threshold for the ANSI Decodability calculation on a code to set a failure condition. The field xxx is the passing threshold for the calculation. For example: if xxx = 037, a Decodability analysis of 36% or lower will cause a failure condition for this parameter.

~PB804xxx100

This command sets the threshold for the ANSI Symbol Contrast calculation on a code to set a failure condition. The field xxx is the passing threshold for the calculation. For example: if xxx = 020, a Symbol Contrast analysis of 19% or lower will cause a failure condition for this parameter.

~LN##

This command sets the minimum number of codes to be read during a sync period. ## = the number of codes. For example: ~LN02 causes a No Read condition to be set if less than 2 bar codes are fully decoded during a sync interval.

~LZ##

This command sets the exact number of codes to be read during a sync period. ## = the number of codes. For example: ~LZ02 causes a No Read condition to be set if exactly 2 bar codes are not fully decoded during a sync interval.

This command overrides the ~LN## command if the number of codes set does not = 00. If ~LZ## is set to ~LZ00, the ~LN## command takes precedence.

~LAXx

This command sets the passing threshold for the Overall ANSI method Symbol Grade. For example: ~LA28 causes an Overall Symbol Grade of 2.7 or lower calculated for the code analyzed to set a failure condition for this parameter.

~Hx

This command stores all parameters into non-volatile memory. This command should be the last command sent after parameters are programmed via the above commands.

Mode 16 (~LV16)

A. Mode 16 I/O operation

1. System will operate in Edge Sync or Envelope sync mode (**~LX#**).
2. Sync polarity programmable (**~LP#**)
3. Use **~PR0200** for proper port initialization.
4. Port 1 will pulse active ON for a bar code quality error condition.
5. Port 2 will pulse active ON for a NO READ, partial or low % decode error condition.
6. Port 3 will pulse active ON for a non-error condition.
7. Port pulse times programmable. (**~PP801xxx**)
8. Pulses act like re-triggerable 1-shot logic
9. Pushing the reset button or power re-cycle will place Ports 1, 2 and 3 in their inactive states and reset the # codes per sync counter.
10. Error conditions available are:
 - a. Partial Read (Programmable, (**~Lp#, LQ#**))
 - b. % decode (Programmable, **~LD##**)
 - c. Bad Quiet Zone: < 10X (**~PB816xxx100**)
 - d. ANSI Defects grade less than B (Programmable, **~PB806xxx000**)
 - e. ANSI Decodability grade less than C (Programmable, **~PB802xxx100**)
 - f. Symbol Contrast grade less than D (Programmable, **~PB804xxx100**)
 - g. Overall ANSI Grade (Programmable, **~LAXx**)
 - h. No Read (if sync is received)
 - i. Number of codes per sync programmable (**~LN##, ~LZ##**)
 - j. X dimension (Programmable **~PB811xxxyyy**)
 - k. Symbology modulo check digit

B. Mode 16 LED Operation

1. LED1 will turn on during the time a Port goes active due to any bar code quality or dimensional error.
2. LED2 will turn on during the time a Port goes active due to a partial or no read condition

Note; Both LEDs can be on in cases where multiple bar codes are analyzed in a sync period.

C. SV Commands Important to Mode 16

This system is operating in a “mode” rather than fully programmable logic. The port activation parameters are programmable via the ~PB8 rather than ~PB1, ~PB2, etc. for each individual port. Other commands, such as mode commands are also available. The commands most useful for this system application are described below. Please see the SV Series Operator’s Guide for additional command description details.

~LV16

This command sets the proper mode for this operation.

~Lp0

This command turns off all partial decode logic at the decoder level

~Lp1

This command turns on partial decode logic at the decoder level

~LQ1

This command allows partial decodes to activate the output ports

~LQ0

This command disables partial decodes to activate output ports.

~PP801xxx

This command sets the “active” time for the port pulses. The value “xxx” sets the time in .1 second intervals. Any value greater than 100 (10 seconds) creates a latching output.

~LDxx

This command sets the % decode threshold for a passing condition. If analyzing poorly printed symbols, it is recommended that partial decodes be enabled at the decoder level when this command is enabled.

xx = failure threshold. Example ~LD75: if 74 % or less of scans on a code were not fully decoded, this sets a failure for this parameter.

~PB816xxx100

This command sets the minimum percent of scans on a code which calculate good quiet zones to determine an acceptable quiet zone analysis. The field xxx is the minimum passing threshold. Example: if xxx = 030, a minimum of 30% of all fully decoded scans on a code must calculate a good quiet zone, or a failure condition is set for this parameter.

~PB806xxx000

This command sets the threshold for the ANSI Defects calculation on a code to set a failure condition. The field xxx is the passing threshold for the calculation. For example: if xxx = 025, a Defects analysis of 26% or higher will cause a failure condition for this parameter.

~PB802xxx100

This command sets the threshold for the ANSI Decodability calculation on a code to set a failure condition. The field xxx is the passing threshold for the calculation. For example: if xxx = 037, a Decodability analysis of 36% or lower will cause a failure condition for this parameter.

~PB804xxx100

This command sets the threshold for the ANSI Symbol Contrast calculation on a code to set a failure condition. The field xxx is the passing threshold for the calculation. For example: if xxx = 020, a Symbol Contrast analysis of 19% or lower will cause a failure condition for this parameter.

~PB811xxxyyy

This command sets the threshold for acceptable X dimension ranges. The value for xxx is the narrowest acceptable X dimension. The value yyy is the widest acceptable X dimension. Units are in .001 inch (mils). For example: ~PB811010020 will cause a failure for n X dimension less than 10 mils or greater than 20 mils.

~LAxx

This command sets the passing threshold for the Overall ANSI method Symbol Grade. For example: ~LA28 causes an Overall Symbol Grade of 2.7 or lower calculated for the code analyzed to set a failure condition for this parameter.

~LN##

This command sets the minimum number of codes to be read during a sync period. ## = the number of codes. For example: ~LN02 causes a No Read condition to be set if less than 2 bar codes are fully decoded during a sync interval. (This system is using edge sync mode, therefore a sync interval is the time between sync inputs.)

~LZ##

This command sets the exact number of codes to be read during a sync period. ## = the number of codes. For example: ~LZ02 causes a No Read condition to be set if exactly 2 bar codes are not fully decoded during a sync interval.

This command overrides the ~LN## command if the number of codes set does not = 00. If ~LZ## is set to ~LZ00, the ~LN## command takes precedence.

~Hx

This command stores all parameters into non-volatile memory. This command should be the last command sent after parameters are programmed via the above commands.

Mode 17 (~LV17)

A. I/O operation

1. System will operate in Edge Sync or Envelope sync mode (~LX#).
2. Sync polarity programmable (~LP#)
3. Use ~PR0200 for proper port initialization.
4. Port 1 will pulse active ON for a bar code quality or data error condition.
5. Port 2 will pulse active ON for a NO READ, partial or low % decode error condition.
6. Port 3 will pulse active ON for a non-error condition.
7. Port pulse times programmable. (~PP801xxx)
8. Pulses act like re-triggerable 1-shot logic
9. Pushing the reset button or power re-cycle will place Ports 1, 2 and 3 in their inactive states and reset the # codes per sync counter.
10. Error conditions available are:
 - a. Partial Read (Programmable, (~Lp#, LQ#)
 - b. % decode (Programmable, ~LD##)
 - c. Bad Quiet Zone: < 10X (~PB816xxx100)
 - d. ANSI Defects grade (Programmable, ~PB806xxx000)
 - e. ANSI Decodability grade (Programmable, ~PB802xxx100)
 - f. Symbol Contrast grade (Programmable, ~PB804xxx100)
 - g. Overall ANSI Grade (Programmable, ~LAXx)
 - h. No Read (if sync is received)
 - i. Number of codes per sync programmable (~LN##, ~LZ##)
 - j. X dimension Range (Programmable ~PB811xxxyyy)
 - k. Ratio (Programmable ~PB815xxx000)
 - l. Symbology modulo check digit
 - m. I 2 of 5 optional Mod 10 Check Digit data error (if enabled)
 - n. Data Match Error (~BC – see Operator’s Guide)
 - o. Increment or Decrement data Error (~Br – see Operator’s Guide)

B. LED Operation

1. LED1 will turn on when Port 1 is active due to ANSI, Symbol Contrast, X dimension, ratio, mod check or quiet zone error conditions.
2. LED1 will flash when Port 1 is active due to a data increment or decrement error condition.
3. LED2 will turn on when Port 2 is active due to a partial, % decode or no read error conditions.
4. LED2 will flash when Port 1 is active due to a Data Match error condition.
5. Flashing on indication will override a solid indication if both types of error conditions occur.

Note; Both LEDs can be on in cases where multiple bar codes are analyzed in a sync period.

C. SV Commands Important for Mode 17

This system is operating in a “mode” rather than fully programmable logic. The port activation parameters are programmable via the ~PB8 rather than ~PB1, ~PB2, etc. for each individual port. Other commands, such as mode commands are also available. The commands most useful for this system application are described below. Please see the SV Series Operator’s Guide for additional command description details.

~LV17

This command sets this mode of operation.

~Lp0

This command turns off all partial decode logic at the decoder level

~Lp1

This command turns on partial decode logic at the decoder level

~LQ1

This command allows partial decodes to activate the output ports

~LQ0

This command disables partial decodes to activate output ports.

~LAxx

This command sets the passing threshold for the Overall ANSI method Symbol Grade. For example:

~LA28 causes an Overall Symbol Grade of 2.7 or lower calculated for the code analyzed to set a failure condition for this parameter.

~LDxx

This command sets the % decode threshold for a passing condition. If analyzing poorly printed symbols, it is recommended that partial decodes be enabled at the decoder level when this command is enabled.

xx = failure threshold. Example ~LD75: if 74 % or less of scans on a code were not fully decoded, this sets a failure for this parameter.

~PP801xxx

This command sets the “active” time for the port pulses. The value “xxx” sets the time in .1 second intervals. Any value greater than 100 (10 seconds) creates a latching output.

~PB816xxx100

This command sets the minimum percent of scans on a code which calculate good quiet zones to determine an acceptable quiet zone analysis. The field xxx is the minimum passing threshold. Example: if xxx = 030, a minimum of 30% of all fully decoded scans on a code must calculate a good quiet zone, or a failure condition is set for this parameter.

~PB806xxx000

This command sets the threshold for the ANSI Defects calculation on a code to set a failure condition. The field xxx is the passing threshold for the calculation. For example: if xxx = 025, a Defects analysis of 26% or higher will cause a failure condition for this parameter.

~PB802xxx100

This command sets the threshold for the ANSI Decodability calculation on a code to set a failure condition. The field xxx is the passing threshold for the calculation. For example: if xxx = 037, a Decodability analysis of 36% or lower will cause a failure condition for this parameter.

~PB804xxx100

This command sets the threshold for the ANSI Symbol Contrast calculation on a code to set a failure condition. The field xxx is the passing threshold for the calculation. For example: if xxx = 020, a Symbol Contrast analysis of 19% or lower will cause a failure condition for this parameter.

~PB815xxx000

This command sets the threshold for the ratio calculation on a code to set a failure condition. The field xxx is the passing threshold for the calculation. For example: if xxx = 025, a ratio analysis of 2.4 or lower will cause a failure condition for this parameter.

~PB811xxxyyy

This command sets the threshold for acceptable X dimension ranges. The value for xxx is the narrowest acceptable X dimension. The value yyy is the widest acceptable X dimension. Units are in .001 inch (mils). For example: ~PB811010020 will cause a failure for an X dimension less than 10 mils or greater than 20 mils.

~LN##

This command sets the minimum number of codes to be read during a sync period. ## = the number of codes. For example: ~LN02 causes a No Read condition to be set if less than 2 bar codes are fully decoded during a sync interval. See the ~LZ## for priority.

If the value ## = 00 (and ~LZ00 is also set), a sync input is disregarded, therefore a No Read condition is disabled.

~LZ##

This command sets the exact number of codes to be read during a sync period. ## = the number of codes. For example: ~LZ02 causes a No Read condition to be set if exactly 2 bar codes are not fully decoded during a sync interval.

This command overrides the ~LN## command if the number of codes set does not = 00. If ~LZ## is set to ~LZ00, the ~LN## command takes precedence.

~Hx

This command stores all parameters into non-volatile memory. This command should be the last command sent after parameters are programmed via the above commands.

Mode 18 (~LV18)

A. I/O operation

1. System will operate Envelope or Edge sync mode (~LX#)
2. Sync polarity – programmable (~LP#)
3. Use ~PR0210 for proper port initialization.
4. Port 1 will go active OFF (no current) on an error condition.
5. Port 2 will go active ON (sink current) on an error condition.
6. Port 3 will operate in per analysis pulse mode. Active polarity ON (sink current), approximately 500 millisecond duration. Port 3 will activate (pulse) on an error condition.
7. Port 4 will operate in per analysis pulse mode. Active polarity ON (sink current), approximately 50 millisecond duration. Port 4 will activate (pulse) on an error condition.
8. Port 5 will pulse active ON for an acceptable condition (absence of error condition.)
9. Port 5 pulse time programmable (~PP801xxx). Pulses will act like a re-triggerable 1-shot.
10. Pushing the reset button or power re-cycle will place Ports 1- 5 in their inactive states.
11. Error conditions available are:
 - a. Partial Read (Programmable, (~Lp#, LQ#)
 - b. % decode (Programmable, ~LD##)
 - c. Bad Quiet Zone: < 10X (~PB816xxx100)
 - d. ANSI Defects grade (Programmable, ~PB806xxx000)
 - e. ANSI Decodability grade (Programmable, ~PB802xxx100)

- f. Symbol Contrast grade (Programmable, ~PB804xxx100)
- g. Overall ANSI Grade (Programmable, ~LAxx)
- h. No Read (if sync is received)
- i. Number of codes per sync programmable (~LN##, ~LZ##)
- j. X dimension Range (Programmable ~PB811xxxyyy)
- k. Ratio (Programmable ~PB815xxx000)
- l. Symbology modulo check digit
- m. 1 2 of 5 optional Mod 10 Check Digit data error (if enabled)
- n. Data Match Error (~BC – see Operator’s Guide)
- o. Increment or Decrement data error (~Br – see Operator’s Guide)

B. LED Operation

1. LED1 will turn on when Ports 1 and 2 are active due to ANSI, Symbol Contrast, X dimension, ratio, mod check or quiet zone error conditions.
2. LED1 will flash when Ports 1 and 2 are active due to a data increment or decrement error condition.
3. LED2 will turn on when Ports 1 and 2 are active due to a partial, % decode or no read error conditions.
4. LED2 will flash when Ports 1 and 2 are active due to a Data Match error condition.
5. Flashing indication will override a solid on indication if both types of error conditions occur.

Note; Both LEDs can be on in cases where multiple bar codes are analyzed in a sync period.

C. SV Commands Important to this System

This system is operating in a “mode” rather than fully programmable logic. The port activation parameters are programmable via the ~PB8 rather than ~PB1, ~PB2, etc. for each individual port. Other commands, such as mode commands are also available. The commands most useful for this system application are described below. Please see the SV Series Operator’s Guide for additional command description details.

~LV18

This command sets this mode of operation.

~Lp0

This command turns off all partial decode logic at the decoder level

~Lp1

This command turns on partial decode logic at the decoder level

~LQ1

This command allows partial decodes to activate the output ports

~LQ0

This command disables partial decodes to activate output ports.

~LAxx

This command sets the passing threshold for the Overall ANSI method Symbol Grade. For example: ~LA28 causes an Overall Symbol Grade of 2.7 or lower calculated for the code analyzed to set a failure condition for this parameter.

~LDxx

This command sets the % decode threshold for a passing condition. If analyzing poorly printed symbols, it is recommended that partial decodes be enabled at the decoder level when this command is enabled. xx = failure threshold. Example ~LD75: if 74 % or less of scans on a code were not fully decoded, this sets a failure for this parameter.

~PP801xxx

This command sets the “active” time for the port pulses. The value “xxx” sets the time in .1 second intervals. Any value greater than 100 (10 seconds) creates a latching output.

~PB816xxx100

This command sets the minimum percent of scans on a code which calculate good quiet zones to determine an acceptable quiet zone analysis. The field xxx is the minimum passing threshold. Example: if xxx = 030, a minimum of 30% of all fully decoded scans on a code must calculate a good quiet zone, or a failure condition is set for this parameter.

~PB806xxx000

This command sets the threshold for the ANSI Defects calculation on a code to set a failure condition. The field xxx is the passing threshold for the calculation. For example: if xxx = 025, a Defects analysis of 26% or higher will cause a failure condition for this parameter.

~PB802xxx100

This command sets the threshold for the ANSI Decodability calculation on a code to set a failure condition. The field xxx is the passing threshold for the calculation. For example: if xxx = 037, a Decodability analysis of 36% or lower will cause a failure condition for this parameter.

~PB804xxx100

This command sets the threshold for the ANSI Symbol Contrast calculation on a code to set a failure condition. The field xxx is the passing threshold for the calculation. For example: if xxx = 020, a Symbol Contrast analysis of 19% or lower will cause a failure condition for this parameter.

~PB815xxx000

This command sets the threshold for the ratio calculation on a code to set a failure condition. The field xxx is the passing threshold for the calculation. For example: if xxx = 025, a ratio analysis of 2.4 or lower will cause a failure condition for this parameter.

~PB811xxxyyy

This command sets the threshold for acceptable X dimension ranges. The value for xxx is the narrowest acceptable X dimension. The value yyy is the widest acceptable X dimension. Units are in .001 inch (mils). For example: ~PB811010020 will cause a failure for an X dimension less than 10 mils or greater than 20 mils.

~LN##

This command sets the minimum number of codes to be read during a sync period. ## = the number of codes. For example: ~LN02 causes a No Read condition to be set if less than 2 bar codes are fully decoded during a sync interval. See the ~LZ## for priority.

If the value ## = 00 (and ~LZ00 is also set), a sync input is disregarded, therefore a No Read condition is disabled.

~LZ##

This command sets the exact number of codes to be read during a sync period. ## = the number of codes. For example: ~LZ02 causes a No Read condition to be set if exactly 2 bar codes are not fully decoded during a sync interval.

This command overrides the ~LN## command if the number of codes set does not = 00. If ~LZ## is set to ~LZ00, the ~LN## command takes precedence.

~Hx

This command stores all parameters into non-volatile memory. This command should be the last command sent after parameters are programmed via the above commands.

Mode 19 (~LV19)

A. I/O operation

1. Envelope type sync input on pin 4
2. Port 3: per sync type. The state of this output must be stable within 12.5 milliseconds after the sync input goes low (trailing edge.) Typical time for stability will be less than 7.5 milliseconds if the sync is received when a bar code or complex graphic is not in the beam. The port shall go active (sink current) for the following error conditions;
 - a. Partial Read (Programmable, (~Lp#, LQ#)
 - b. % decode (Programmable, ~LD##)
 - c. Bad Quiet Zone: < 10X (~PB816xxx100)
 - d. ANSI Defects grade (Programmable, ~PB806xxx000)
 - e. ANSI Decodability grade (Programmable, ~PB802xxx100)
 - f. Symbol Contrast grade (Programmable, ~PB804xxx100)
 - g. Overall ANSI Grade (Programmable, ~LAXx)
 - h. No Read (if sync is received)
 - i. Number of codes per sync programmable (~LN##, ~LZ##)
 - j. X dimension Range (Programmable ~PB811xxxyyy)
 - k. Ratio (Programmable ~PB815xxx000)
 - l. Symbology modulo check digit
 - m. I 2 of 5 optional Mod 10 Check Digit data error (if enabled)
 - n. Data Match Error (~BC – see Operator’s Guide)
 - o. Increment or Decrement data error (~Br – see Operator’s Guide)
3. Sync polarity - Leading edge high going; time between trailing (low going) edge to leading edge - 12.5 milliseconds minimum
4. Port 1; acts as strobe (signal ensuring Port 3 condition is stable) in response to trailing edge of sync input. This signal will go “on” (sink current) between 20 and 100 microseconds after Port 3 condition is stable.
5. Ports 1 and 3 will go high (no current) within 12.5 milliseconds after the sync input goes high (leading edge).
6. Use ~PR0200 for proper port initialization.

B. LED Operation

1. LED1 will turn on when Port 3 is active due to ANSI, Symbol Contrast, X dimension, ratio, mod check or quiet zone error conditions.
2. LED1 will flash when Port 3 is active due to a data increment or decrement error condition.
3. LED2 will turn on when Port 3 is active due to a partial, % decode or no read error conditions.
4. LED2 will flash when Port 3 is active due to a Data Match error condition.
5. Flashing indication will override a solid on indication if both types of error conditions occur.

Note; Both LEDs can be on in cases where multiple bar codes are analyzed in a sync period.

C. SV Commands Important to this System

This system is operating in a “mode” rather than fully programmable logic. The port activation parameters are programmable via the ~PB8 rather than ~PB1, ~PB2, etc. for each individual port. Other commands, such as mode commands are also available. The commands most useful for this system application are described below. Please see the SV Series Operator’s Guide for additional command description details.

~LV19

This command sets this mode of operation.

~Lp0

This command turns off all partial decode logic at the decoder level

~Lp1

This command turns on partial decode logic at the decoder level

~LQ1

This command allows partial decodes to activate the output ports

~LQ0

This command disables partial decodes to activate output ports.

~LAxx

This command sets the passing threshold for the Overall ANSI method Symbol Grade. For example:

~LA28 causes an Overall Symbol Grade of 2.7 or lower calculated for the code analyzed to set a failure condition for this parameter.

~LDxx

This command sets the % decode threshold for a passing condition. If analyzing poorly printed symbols, it is recommended that partial decodes be enabled at the decoder level when this command is enabled.

xx = failure threshold. Example ~LD75: if 74 % or less of scans on a code were not fully decoded, this sets a failure for this parameter.

~PB816xxx100

This command sets the minimum percent of scans on a code which calculate good quiet zones to determine an acceptable quiet zone analysis. The field xxx is the minimum passing threshold. Example: if xxx = 030, a minimum of 30% of all fully decoded scans on a code must calculate a good quiet zone, or a failure condition is set for this parameter.

~PB806xxx000

This command sets the threshold for the ANSI Defects calculation on a code to set a failure condition. The field xxx is the passing threshold for the calculation. For example: if xxx = 025, a Defects analysis of 26% or higher will cause a failure condition for this parameter.

~PB802xxx100

This command sets the threshold for the ANSI Decodability calculation on a code to set a failure condition. The field xxx is the passing threshold for the calculation. For example: if xxx = 037, a Decodability analysis of 36% or lower will cause a failure condition for this parameter.

~PB804xxx100

This command sets the threshold for the ANSI Symbol Contrast calculation on a code to set a failure condition. The field xxx is the passing threshold for the calculation. For example: if xxx = 020, a Symbol Contrast analysis of 19% or lower will cause a failure condition for this parameter.

~PB815xxx000

This command sets the threshold for the ratio calculation on a code to set a failure condition. The field xxx is the passing threshold for the calculation. For example: if xxx = 025, a ratio analysis of 2.4 or lower will cause a failure condition for this parameter.

~PB811xxxyyy

This command sets the threshold for acceptable X dimension ranges. The value for xxx is the narrowest acceptable X dimension. The value yyy is the widest acceptable X dimension. Units are in .001 inch (mils). For example: ~PB811010020 will cause a failure for an X dimension less than 10 mils or greater than 20 mils.

~LN##

This command sets the minimum number of codes to be read during a sync period. ## = the number of codes. For example: ~LN02 causes a No Read condition to be set if less than 2 bar codes are fully decoded during a sync interval. See the ~LZ## for priority.

If the value ## = 00 (and ~LZ00 is also set), a sync input is disregarded, therefore a No Read condition is disabled.

~LZ##

This command sets the exact number of codes to be read during a sync period. ## = the number of codes. For example: ~LZ02 causes a No Read condition to be set if exactly 2 bar codes are not fully decoded during a sync interval.

This command overrides the ~LN## command if the number of codes set does not = 00. If ~LZ## is set to ~LZ00, the ~LN## command takes precedence.

~Hx

This command stores all parameters into non-volatile memory. This command should be the last command sent after parameters are programmed via the above commands.

Mode 20 (~LV20)

This mode is identical to Mode 19 with the exception the sync polarity is reversed. The leading edge is low going.

ANSI PARAMETER GRADE THRESHOLDS

ANSI parameter fail thresholds are set in the SV Series by commands requiring numeric settings that correlate to the parameter calculations. Below are descriptions of how the numeric calculations are divided into letter grades per the ANSI Bar Code Quality Specification

R_{min}

$$A \leq .5 \times R_{\max}$$

$$F > .5 \times R_{\max}$$

Symbol Contrast

$$A \geq 70\%$$

$$B \geq 55\%$$

$$C \geq 40\%$$

$$D \geq 20\%$$

$$F < 20\%$$

Minimum. Edge Contrast

$$A \geq 15\%$$

$$F < 15\%$$

Modulation

$$A \geq .70$$

$$B \geq .60$$

$$C \geq .50$$

$$D \geq .40$$

$$F < .40$$

Decodability

$$A \geq .62$$

$$B \geq .50$$

$$C \geq .37$$

$$D \geq .25$$

$$F < .25$$

Defects

$$A \leq .15$$

$$B \leq .20$$

$$C \leq .25$$

$$D \leq .30$$

$$F > .30$$

Conversion of letter scan grade to numeric grade

$$A=4, B=3, C=2, D=1, F=0$$

Conversion of numeric symbol grade to letter symbol grade (used in averaging)

$$3.5 \leq A \leq 4.0$$

$$2.5 \leq B < 3.5$$

$$1.5 \leq C < 2.5$$

$$0.5 \leq D < 1.5$$

$$F < 0.5$$

Reference Decode

A = ANSI method algorithm decoded the symbol

F = ANSI method algorithm could not decode the symbol

APPENDIX A; SV SERIES SETUP HINTS

Introduction

The RJS SV Series of Scanner/Verifiers requires a fixed scanning distance and angle for maximum verification analysis accuracy. This is similar to the requirement of a wand “guide” on a portable bar code verifier to ensure the optics is placed at a consistent angle. If the “guide” is not placed properly, analysis results will become inaccurate, although the bar code will still be decoded.

This document is intended to provide some hints to help make the basic scanning setup as easy and quick as possible in order to allow more time to concentrate on the application portion of the installation.

This document is written with the assumption that RJS ScanVision software is being used as the setup tool. ScanVision is available for download from the RJS web site at www.rjs1.com. A null modem serial communication cable is required to interface the PC to an SV unit during the setup process. An appropriate power / interface cable must also be connected in order to operate the SV unit.

It is highly recommended to have a SV Series Operator’s Guide for reference while reading this document.

Setting the Proper Scan Distance

A proper and fixed scan distance is required to make sure the laser beam is in focus, therefore providing the correct optical resolution for the particular SV model. The specified scan distance is indicated on a label on the side of each unit.

The SV Series’ feature of being able to measure a bar code’s X dimension makes it convenient for setting up scan distance. In the manufacturing process each SV unit is programmed to accurately measure the X dimension when scanning at the optimum distance. Therefore, if the analysis of a bar code with a known X dimension indicates an accurate result, the scanner is set to the proper scan distance. Below are some basic steps to set the proper scan distance using the X dimension as the adjustment factor:

1. Place the SV Calibration symbol (supplied with each SV unit) in the laser beam.
2. Roughly adjust the scan distance so the READ led is on.
3. Press the SPACE bar in ScanVision to get an analysis of the code.
4. Adjust scan distance until the X dimension matches the cal symbol’s X dimension within +/- .1 mil. All RJS calibration symbols have a 10 mil X dimension unless otherwise specified on the symbol. Note: a scan distance too close will read a larger than the known X dimension. Too far will read smaller than the known dimension. The X dimension is titled “X (mils)” in the ScanVision Session Mode display as shown in Figure 1.

Once the Scan distance (and angle – see setting proper angle) is set, the SV unit does not have to be moved again.

Figure 1 – Session Mode Screen Showing the X Dimension Measurement

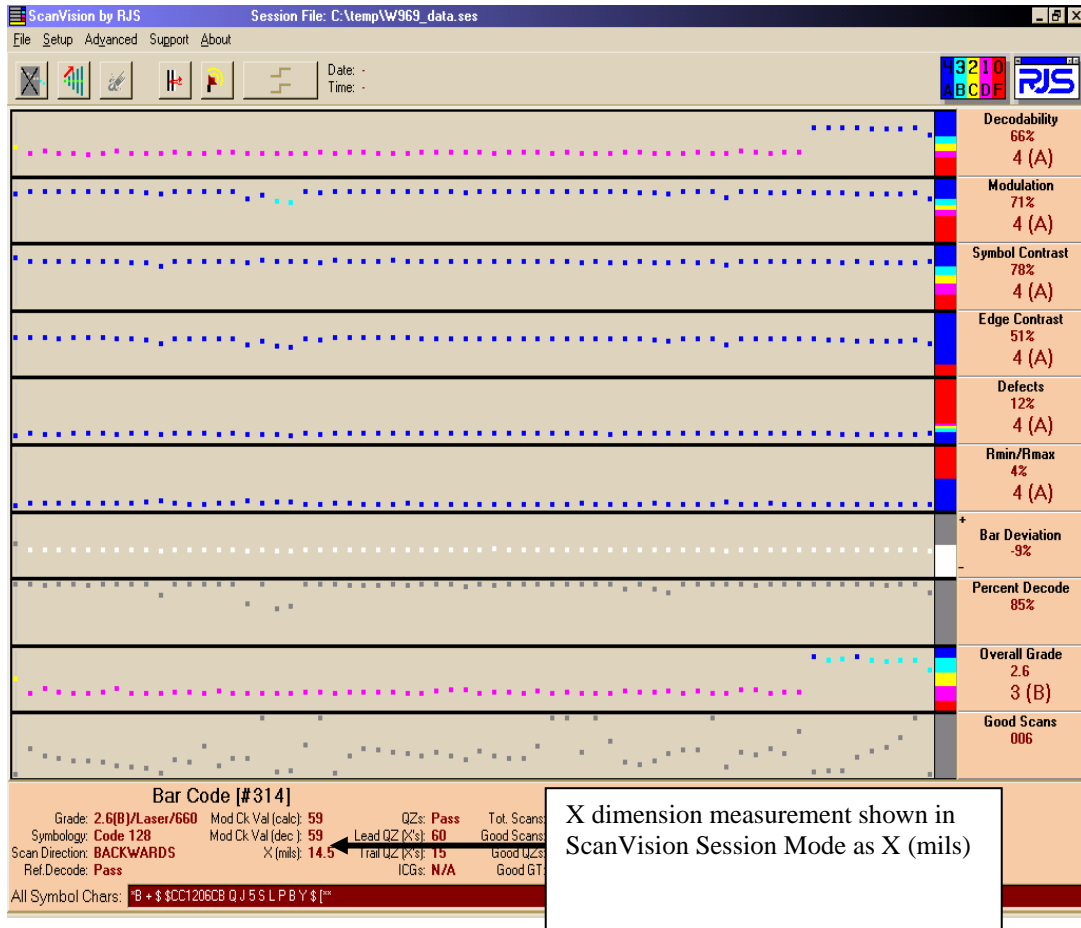

Setting the Proper Scan Angle

The SV Series requires a fixed scanning angle for two basic reasons:

1. To maintain proper scanner signal levels in order to effectively decode symbols.
2. To accurately calculate reflectance parameters.

Acceptable scanning angles range from 10 to 35 degrees from vertical (relative to the bar code being scanned) depending on the material being scanned, mounting considerations, etc.

SV units incorporate proprietary, analog scanners. The scanner gain and offset are adjustable, allowing the units to adapt to practically any material. ScanVision software allows easy setup of scanner gain and offset. A quick method of adjusting the scanner using a special command ~Sc is described below. If the “quick method” described below is unsuccessful, follow the setup procedure in the SV Series Installation and Setup Procedures section using the ~Hd commands.

1. Set the SV unit in moving codes mode and picket fence bar code orientation via the ScanVision Setup menus.
2. Place the SV unit at an angle as close as possible to 22 degrees from vertical (relative to the bar code) and at the correct scanning distance from the bar code to be analyzed. (See the Setting the proper scan distance section above.)
3. Place an SV Calibration symbol in the laser beam at the same distance and angle that will be used in the final application.

4. Go to the Transmit a Command screen by clicking on the  button

5. Send the command ~Sc (lower case “c”)
6. Leave the screen by clicking on the RETURN button on the bottom of the Screen.
7. Press F3 to get a Reflectance profile Screen.
8. Confirm the signal levels are between the yellow lines and flat on the bottom as shown in Figure 2. If correct, go to step 10.
9. If the bottom of the signal is not flat, change the scan angle and repeat steps 3 – 7. If the code’s signal amplitude is not within the yellow lines, follow the Setup procedure in the SV Series Operator’s Guide by using the ~Hd commands. (See Figure 3)
10. At this point, the scanner gain and offset are compatible with the Calibration symbol’s contrast. Place an actual symbol being used in the application in the beam at the proper distance and angle.
11. Press the “New Profile” in the Reflectance Profile screen button to get a Reflectance Profile
12. Confirm the signal levels are between the yellow lines, amplitude is 5 lines high minimum and flat on the bottom as shown in Figure 2. **If correct, the scanner is set up for the material in the application.** Go to Step 13.
13. If the bottom of the signal is not flat, or the signal level is not within the yellow lines (see Figure 3), or at least 5 lines in amplitude, **the material used in the application is not adaptable to scanner settings compatible with the calibration symbol. Use steps 3-8 to adjust the scanner gain and offset for this material and do not use any parameters that involve reflectance measurements for failure detection for this application. See the Calibration Hints section.**
14. **IMPORTANT!!** At this point the scanner is set up for the material in the application and the ~Sc command has been used at least once to change the scanner’s setting from the initial state. To finalize the settings, **transmit the SV command ~Hx (lower case x).** This will save the new settings to non-volatile memory for permanent operation.
15. The SV unit is now ready to be programmed for any application specific requirements using output interface modes, or other modes of scanning operation such as ladder orientation, static codes mode, etc.

Figure 2 – Example of “Good” Scan Profile

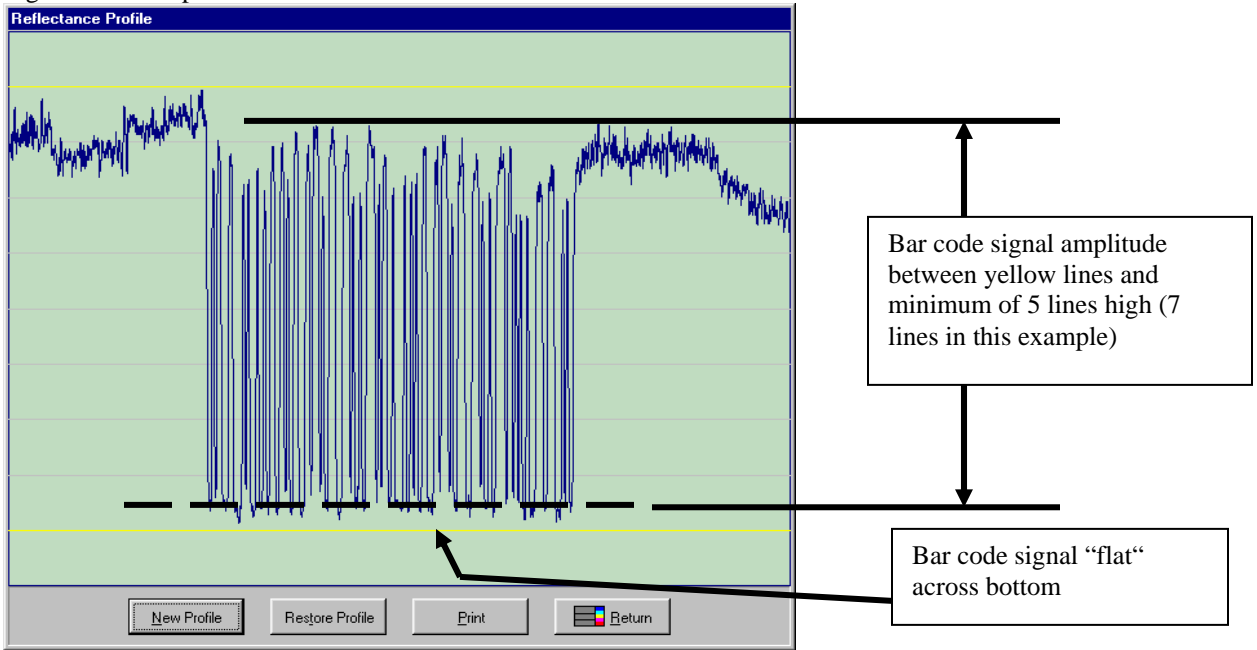
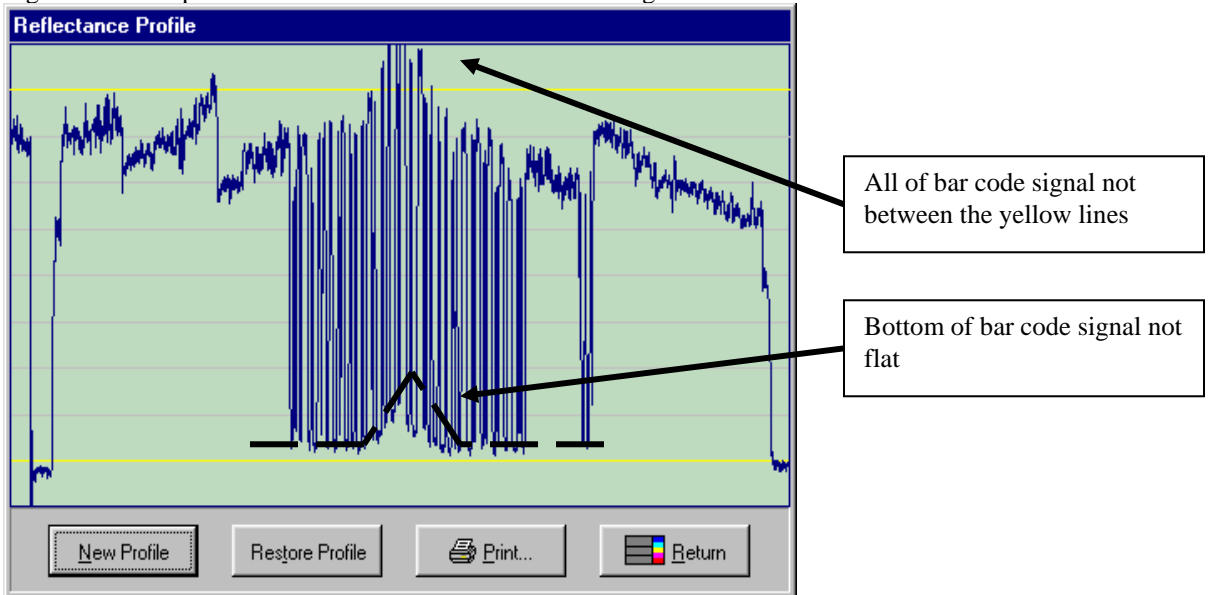

Figure 3 – Examples of Scan Profile Parameters Out of Range



Calibration Hints

Calibration is used to normalize reflectance calculations to known (and/or traceable) values in absolute units of % reflectance. **Calibration affects reflectance calculations only. Calibration does not affect** any other calculations or ability to decode a symbol, etc. The scanner gain and offset settings have the major effect on scanning performance. Keeping the scanner signal linear (between the yellow lines as described in the distance and angle setup sections above) is very helpful for good decoding, but is **CRUCIAL** for reflectance measurements. The calibration procedure will not be successful unless the bar code signal is proper.

There may be cases in applications where the material being analyzed requires a scanner gain and offset setting that will not allow calibration with the standard SV calibration symbol. In most cases this is due to a low contrast material (such as brown corrugated) that will make the signal level on the calibration symbol go past the yellow lines. In cases like this there are two basic choices to make:

1. Do not use parameters that involve absolute units of reflectance as failure criteria. These parameters include Symbol Contrast, Overall ANSI Grade, PCS, Rmax, and Rmin.
2. If reflectance parameters are required to be analyzed in the application, a calibration symbol can be created from the material being analyzed. Contact RJS Technical Support for details.