

UPR800 Series

Process Indicator

1/4 DIN Panel Display of Pressure and Temperature



Stocked, Distributed, and Supported by

SENSORS
INCORPORATED

507 Kelsey Street • Delano, MN 55328
Phone 763-972-1040 Fax 763-972-1041
Toll Free 888-920-0939
Sensorsincorporated.com

DOC974144
REV010109





Table Of Contents

QUICK START INSTRUCTION.....	5
Mounting.....	5
Wiring.....	6
Scaling.....	6
Calibration and Operation.....	6
1.0 INTRODUCTION.....	7
2.0 SPECIFICATIONS.....	9
2.1 Mechanical Specifications.....	9
2.2 Main Power Supply & Environmental Specification.....	9
2.3 Display Specifications.....	10
2.4 Primary Input.....	11
2.5 Secondary Input (optional).....	12
2.6 Primary & Secondary Analog Inputs Common.....	13
2.7 Digital Input Specification.....	14
2.8 Alarms.....	14
2.9 Optional Serial Communication Interface Specification.....	15
2.10 Main Analog Output Specification.....	15
2.11 Second Analog Output Specification.....	15
2.12 Primary & Secondary Analog Outputs Common Specification.....	16
3.0 UNPACKING.....	19
4.0 DIMENSIONAL INFORMATION.....	20
5.0 HARDWARE.....	21
6.0 MOUNTING AND WIRING.....	22
Terminal Assignments.....	24
UPR700 to UPR800 Wiring Conversion Table.....	25
7.0 START-UP PROCEDURE.....	27
7.1 Getting Ready:.....	27
7.2 Configuring the UPR800:.....	27
7.3 Keyboard Description:.....	28
7.4 Operating Mode Description:.....	28
8.0 CONFIGURATION.....	30
8.1 Parameters.....	30
8.2 Parameter Configuration Procedures.....	30
8.2.1 Setting the Logic Input Configuration (if supplied).....	31
8.2.2 Setting the Logic Input Status (if supplied).....	31
8.2.3 Setting Peak Detection.....	31
8.2.4 Setting the Line Frequency.....	31
8.2.5 Setting the Display Filter.....	32
8.3 Primary Input Setup.....	33
8.3.1 Setting the Primary Input Type for a Strain Gage Transducer.....	33

8.3.2	Setting the Shunt Calibration for Strain Gage Transducers and Amplified units	33
8.3.3	Setting the Primary Input Type for an Amplified Transmitter	34
8.3.4	Setting the Primary Input Full-Scale Value	34
8.3.5	Setting the Primary Input Low-Scale Value	34
8.3.6	Setting the Primary Input Decimal Place	35
8.3.7	Setting the Primary Input Failsafe Mode	35
8.4	Secondary Input Setup	35
8.4.1	Setting the Secondary Input Type	35
8.4.2	Setting the Secondary Input Scale and Decimal Point	36
8.4.3	Setting the Thermocouple Type and Units	36
8.4.4	Setting the Secondary Input Failsafe Mode	36
8.5	Setting the Alarms	37
8.5.1	Setting Channel Alarm to Monitor (Alarm Input Channel Link)	37
8.5.2	Setting Alarm Type	38
8.5.3	Setting the Filtering for Alarm 1	38
8.5.4	Setting the Hysteresis for Alarm	38
8.5.5	Setting the Reset Mode for Alarms	38
8.5.6	Setting the Failsafe Mode for Alarms	39
8.5.7	Setting the Alarms Value (Alarms Threshold)	39
8.5.8	Setting the Alarms Mask Reset Type	39
8.6	Main Analog Output Setup	40
8.6.1	Setting the Main Analog Output Type	40
8.6.2	Setting the Main Analog Output Link	40
8.6.3	Setting the Main Analog Output Range Low	40
8.6.4	Setting the Main Analog Output Range High	40
8.6.5	Setting the Main Analog Output Filter	41
8.7	Setting the Security Codes	41
8.7.1	Setting the Security Codes for Level A	41
8.7.2	Setting the Security Codes for Level B	41
8.7.3	Setting the Security Codes for Level C	41
8.7	Configure Differential Pressure	42
8.8	Configure by Remote PC (Configuration Port Interface or CPI)	47
9.0	OPERATION	48
9.1	Primary Input Calibration	48
9.1.1	Calibration of Pressure Transducers Equipped with an Internal Shunt Resistor	48
9.1.2	Calibration of Amplified Pressure Transmitters with an Internal Shunt Resistor	48
9.1.3	Calibration of Pressure Transducers with External Shunt Resistors	48
9.1.4	Calibration of Analog Inputs Using a Pressure Calibration Source	49
9.1.5	Calibration of the UPR800 to Calibrated Linear Analog Input	49
9.2	Instrument Calibration	50
9.2.2	General Calibration Procedure	50
9.3	RS-485 (Optional)	53
9.3.1	Serial Communication Interface Address	53
9.3.2	Protocol Type	54
9.3.3	Communication Type	54
9.3.4	Communication Baud Rate	54
10.0	ERROR CODES	55

10.1 Error Codes and Troubleshooting.....	55
10.2 “OPEN” Error Code and Troubleshooting	56
10.3 Instrument Maintenance.....	56
11.0 NORMATIVE REFERENCES	58
12.1 Group 1 Parameters.....	62
12.2 Group 2 Parameters.....	63
12.3 Group 3 Parameters.....	65
12.4 Group 4 Parameters.....	70
12.5 Group 5 Parameters.....	73
12.6 Group 6 Parameters.....	74
13.0 WARRANTY AND SERVICE:	76

Symbols used on the labeling	
	Refer to the Manual for instruction
	Functional Earth

One or more of the symbols below may appear on the labelling

QUICK START INSTRUCTION

Mounting

- Prepare panel cutout to dimensions shown below.
- If more instruments are mounted in the same panel near together, maintain the distances between one instrument to another like as in the figure.
- Slide the rubber gasket (1) over the case.
- Slide the instrument case into the cutout.
- Attach the panel mounting hardware tightening the threaded rod (3) for a secure fit and with a screwdriver, turn the screws with a torque between 0.3 and 0.4 Nm.

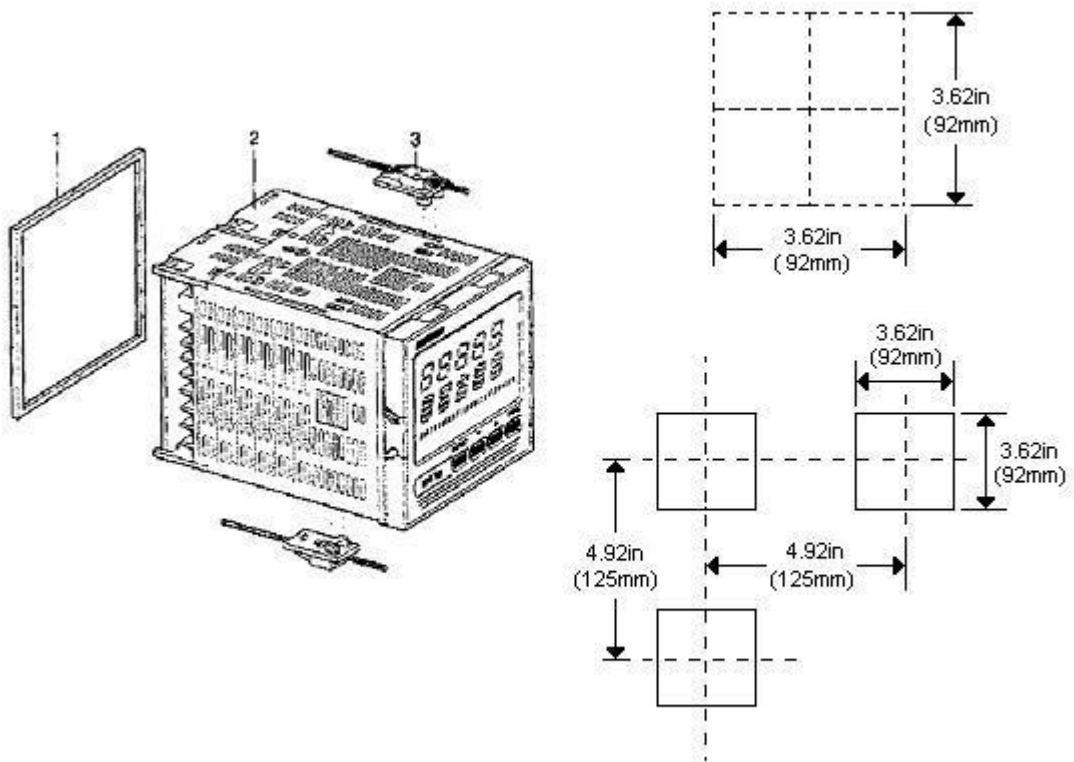

All dimensions are in inches (millimeters) unless otherwise specified

Wiring

- Connect the wires from transducer cable as shown in the terminal diagram, turn the screws with a torque between 1.0 and 1.2 Nm.
- Connect an appropriate length of thermocouple extension wire (Type J) to the connector.
- Connect the thermocouple to the appropriate terminals (remember that red is negative).
- Connect alarm(s) if applicable. Note that alarm defaults are High, Reverse Acting.
- Connect power to the appropriate terminals as shown.

Scaling

- Apply power to the instrument; Upper display will give a reading near zero. Lower display will read the actual temperature.
- Press FUNC key until the Upper display reads NONE. Lower display reads GROUP.
- If your transducer is not a 10,000-psi model, select Group 3 using the Up arrow, enter with function key.
- Lower display reads PI.FSV (Full Scale Value), and the upper display reads 10,000. **Note:** If your transducer is a 10,000 psi model skip next two steps. Scroll to GROUP.
- Using the Down arrow key set the appropriate Full Scale Value for your transducer.
- Enter using the FUNC key to scroll until GROUP legend appears again.
- Using Up arrow key, select GROUP 2.

Calibration and Operation

- Lower display reads ZERO.C and upper display reads OFF. Be sure transducer is at operation temperature and that no pressure is applied.
- Change upper display to ON by using the Up arrow key. Enter with the FUNC key. After a few seconds, the lower display will show SPAN.C and upper display will show OFF.
- Change upper display to ON using Up arrow key. Enter with the FUNC key. In a few seconds lower display shows DSP.FL and upper display shows 0.4. Calibration is complete.
- Using the FUNC key, scroll to the GROUP display. Enter 1 with the Up arrow, and enter with the FUNC key. Instrument shows 0 (± 10) on upper display and temperature on lower display. System is ready for use.

References to Profibus features and instructions should be ignored. Profibus is being considered for a future line expansion and has been accommodated in the current design.

1.0 INTRODUCTION

The UPR800 Pressure/Process Indicator is a microprocessor-based instrument, with the capability of monitoring one or two process variables simultaneously. The primary input is user configurable to be 350Ω Strain Gage, high-level voltage or high level current. If the second input option is chosen, it is configurable by the user as any of four thermocouples, PT-100 RTD, high-level voltage or high level current. They are compatible with many process transmitters and can be scaled by the user to give an appropriate range in engineering units. The UPR800, in its dual input version, can provide simultaneous readout of common process variable pairs such as Pressure and Temperature, Temperature and Humidity, etc., when used with the appropriate sensor / transmitter combinations. Pressure value input and retransmission output groups are selected though the keypad. Thus the need to make numerous selections within the instrument is minimized. The UPR800 is provided with two alarms and an analog retransmission output any of which can be assigned to the primary or secondary input. A second analog retransmission output is available as an option, as is a 24Vdc power supply for two and four wire process transmitters. A third alarm is also available as an option.

Five groups of configuration parameters are available from the keyboard, and are protected by three levels of user definable software locks. The displays can be single-line (primary input only; lower display blanked), dual line with primary input in the upper display and high or low peak in the lower display, or dual display of primary input in the - upper display and secondary input in the lower display. In the last mode, the lower display can alternate between the secondary input and the primary input peak value via keystroke. In addition, a red LED bar graph presents an analog representation of the primary input, as well as indication of the alarm set points.

References to Profibus features and instructions should be ignored. Profibus is being considered for a future line expansion and has been accommodated in the current design.

WARNING NOTE: The user should be aware that if this equipment is used in a manner not consistent with the specifications and instructions in this manual, the protection provided by the equipment might be impaired.

Product (Model) Codes

Model	Input	Options	Power
	Code Description	Code Description	Code Voltage
UPR800-	0 Not Present	0 No Option	3 100-240 Vac (switching)
	1 T/C, RTD, mV, mA/V	2 24 Vdc transmitter power supply and 2 nd analog retransmission.	5 24 Vac/Vdc (switching)
		3 24 Vdc transmitter power supply and 2 nd analog retransmission & RS-485	

DYNISCO UPR800 Series Instruction Manual

Instruments with the suffix - A3 after the model number have the optional third alarm.

Note: UL pending only for Power Code Voltage equal to 5 (24 Vac/Vdc, switching)

2.0 SPECIFICATIONS

2.1 Mechanical Specifications

Case: Polycarbonate Black color Self-extinguishing degree VO according to UL 94

Front Panel: Designed and verified for IP65 and NEMA 4X for indoor location

Installation: Panel mounting

Rear Terminal Block: 43 screw terminals with rear safety cover

2.2 Main Power Supply & Environmental Specification

Main Power Supply: From 100 to 240Vac (-15% to 10%), 50/60 Hz switching. Option: 24Vac/dc

Power supply variation: From -15% to 10% (for 100 to 240Vac). From 14 to 32 Vac/dc (for optional 24Vac/dc).

Power Consumption: Max 22 VA at 50 Hz; Max 27 VA at 60 Hz

Insulation Resistance: 100 M Ω @500Vdc

Dielectric Strength: 1500V rms for 1 min, 1800V for 1 sec

Ambient Temperature: From 0 to 50°C

Storage Temperature: From -20 to 70°C

Humidity: Max 85% RH non-condensing

Watchdog: Hw/Sw is provided for automatic restart

Agency Approvals: UL File # 193253

Self-Certification: CE

Electromagnetic Compatibility and Safety Requirements: The instrument is CE Marked. It is compliant with the European Directive 2004/108/CE according to Product Standard EN 61326-1.

Emission limit: class A – group 1 ISM for equipment suitable for use in all establishments other than domestic and those directly connected to a low voltage power supply network which supplies buildings used for domestic purposes.

Immunity:

- Electrostatic discharge (according to EN 61000-4-2):
contact discharge = 4kV; air discharge = 8kV
- Radio-frequency electrical magnetic (according to EN 61000-4-3):
EM field (amplit. mod.) = 10 V/m (80 MHz to 1 GHz);
3V/m (1,4 GHz to 2 GHz);
1 V/m (2 GHz to 2,7 GHz)
- Electrical fast transient/burst (according to EN 61000-4-4):
AC Power = 2kV;
I/O Signal/Control = 2kV (5/50 ns, 5 kHz);
I/O Signal/Control connected directly to mains supply = 2kV (5/50 ns, 5 kHz)
- Surge (according to EN 61000-4-5):
AC power = 1kV (Line to Line) / 2kV (Line to GND);
I/O Signal/Control = 1kV (Line to Line) / 2kV (Line to GND)
- Radio frequency common mode (according to EN 61000-4-6):
AC Power = 3 V (150kHz to 80 MHz);
I/O Signal/Control = 3 V (150kHz to 80 MHz)
- Voltage dips/short interruptions (according to EN 61000-4-11):
0% during 1 cycle; 40% during 12 cycles; 70% during 30 cycles

This equipment is intended for use in an industrial location. There may be potential difficulties ensuring electromagnetic compatibility in other environmental due to conducted as well as radiated disturbances.

Safety Requirements:

The instrument is compliant with the European Directive 2006/95/CE according to Reference Standard EN 61010-1 for installation category I and pollution degree 2

Installation category CAT I: Voltage transients on any power connected to the instrument must not exceed 1.5kV.

Pollution degree 2: Conductive pollution must be excluded from the cabinet in which the instrument is mounted.

2.3 Display Specifications

Display: LED technology, custom type.

Upper Digits: Red color, 5 numeric digits, 7 segments with decimal point 13.2mm high.

Lower Digits: Green color, 5 alphanumeric digits (British flag), 14 segments with decimal points. 11.3mm high.

Bar Graph: Red color, 35 segment with 3% resolution. Displays continuous bar graph to indicate the measured variable of the primary input (0-100% full scale). Alarm set point values displayed. Last segment blinks for pressure greater than full scale value.

Indicators (Beacons):

Red LED's annunciations:

- A1: Lit when alarm 1 is in alarm state
- A2: Lit when alarm 2 is in alarm state
- A3: Lit when alarm 3 is in alarm state
- REM: Lit when device is controlled by serial link
- 0-25-50-75-100-%: These six LEDs are always on to improve the bar graph indication.
- Kg/cm², PSI, Bar, MPa: Engineering unit for the pressure input. These four beacons are located within the display window, between the numeric digits and the alarm beacons.

Green LED's annunciations:

- PEAK: Lit when lower display shows the peak value
- TEMP: Lit when lower display shows the temperature input value

2.4 Primary Input

Primary Input: Selectable between strain gage and linear by software configuration.

Strain Gage Input: From 340 to 5000Ω, 1-4mV/V. Excitation 10V ±7%. 5 wire connection.

Input Signal: -25/125% of full scale (approximately -10 / 50mV).

Shunt Calibration: With or without shunt resistor (value programmable from 40.0 to 100.0%).

Zero Balance: ±25% of full scale (approximately ± 10mV).

Linear Input: Selectable between 0-5Vdc, 0-10Vdc. 0-20mA, 4-20mA.

Auxiliary Power supply: 24Vdc / 1.5W ± 2% power supply for two or four wire transmitter.

Input Impedance:

- <10Ω for linear current input
- >165KΩ for linear voltage input

Input Protection: Open circuit detection for strain gage (on signal and excitation wires) and 4-20mA inputs; it is not available for 0-5Vdc, 0-10Vdc and 0-20mA. Up or down scale keyboard programmable.

Sampling Time: 50mS typical.

Display Update Time: Selectable: 50, 100, 250 or 400mS.

Engineering Units: Dedicated beacons within the display window.

Calibration mode: Field calibrations (zero and span) are applicable for both strain gage and linear input. Moreover it is possible to delete the field calibration done by the end user and to restore original factory calibration values.

Input resolution: 4000 counts.

Full scale value	Resolution
10/4000	1 count
4002/8000	2 counts
8005/20000	5 counts
20010/40000	10 counts
40020/80000	20 counts
80050/99950	50 counts

Decimal Point Settable in any position of the display.

2.5 Secondary Input (optional)

Temperature Input: Selectable between linear, thermocouple or RTD input by software configuration.

Function: Selectable between: temperature (in case of linear, thermocouple, RTD the input); second sensor for the measurement of a differential pressure (in case of strain gage or linear input)

Linear Input: Selectable between 0-5Vdc, 0-10Vdc, 0-20mA, and 4-20mA

Sensor Type and Range:

Thermocouple J	-200/+800°C	-328/+1472°F
Thermocouple K	-200/+1200°C	-328/+2192°F
Thermocouple L	-200/+800°C	-328/+1472°F
Thermocouple N	0/1300°C	32/+2372°F
Thermocouple T	-200/+400°C	-328/+752°F
Thermocouple E	-200/+600°C	-328/+1112°F
RTD Pt100	-200/+600°C	-328/+1112°F
RTD Pt500	-200/+600°C	-328/+1112°F

Input Protection: Open circuit detection for strain gage (on signal and excitation wires), thermocouple, RTD and 4-20mA inputs; not available for 0-10Vdc, 0-5Vdc and 0-20mA inputs. Up or down scale keyboard.

Input Impedance:

- >1MΩ for thermocouple input.
- <10Ω for linear current input

>165K Ω

T/C Lead Length: 100 Ω max.

Reference Junction Compensation: from -20 to 60°C.

RTD measure system: 3 wire.

RTD Lead Length Compensation: Up to 20 Ω /wire for the Pt100 and Pt500.

Sampling Time: Temperature input is selectable among 100, 200, 500 or 1000mS; differential pressure is 50 mS, typical.

Display Update: At each sample.

Input Resolution with Linear Input: 4000 counts.

Low/High Scale Values: From -1000 to 3000, linear inputs only. Secondary differential pressure is selectable, but with the same resolution and decimal point position of the primary pressure input.

Decimal point: Settable in any position.

NOTE: These secondary inputs are not isolated from the primary input. A double or reinforced insulation between instrument output and power supply must be guaranteed by the external device.

2.6 Primary & Secondary Analog Inputs Common

Common Mode Rejection Ratio: >120dB @50/60Hz

Normal Mode Rejection Ratio: >60dB @ 50/60Hz

Strain gage input: From 340 to 5000 Ω , 1-4 mV/V. Excitation 10V +/- 7%. 5 wires connection.

Input signal: -25/125% of full scale (approximately -10/50mV).

Shunt calibration: With or without shunt resistor (value programmable from 40.0 to 100.0%), the same setting will be used for both inputs (main and secondary) when the differential pressure measurement is selected.

Zero balance: +/- 25% of full scale (approximately +/- 10mV).

Reference accuracy: +/- 0.1% FSV +/-1 digit @ 25 +/- 1°C and nominal power supply voltage.

Operative accuracy: temperature drift:

- < 200 ppm/K of full span (RJ excluded) for TC input.
- < 300 ppm/K of full span for current, voltage and strain gage input.
- < 400 ppm/K of full span for RTD input.
- < 0.1K/K for reference junction.

Zero and span calibration: If differential input used, there is no relation between the calibration of the two single sensors; each input is provided with its own zero and span calibration parameters.

2.7 Digital Input Specification

Digital input: One input from contact closure (voltage free). It may be keyboard programmable for the following functions:

- Alarm reset
- Peak reset
- Alarm and peak reset

NOTE: This input is not isolated from primary input. A double or reinforced insulation between instrument output and power supply must be guaranteed by the external device.

2.8 Alarms

Alarm Outputs: 2 standard alarms (AL1 and AL2). 1 optional alarm (AL3).

AL1 and AL2 Contacts: 1 SPDT 2A max 0 240Vac resistive load.

AL3 Contacts: 1 SPST selectable NO/NC 2A max @ 240Vac resistive load.

Contact Protection: Varistor for spike protection.

Alarm Type: Each alarm is keyboard programmable for:

- Primary/Secondary input
- High/Low/Low inhibited on start up
- Auto/Manual reset

Excitation Type: Keyboard configurable for each alarm: relay coil energized in no alarm condition (failsafe) or relay coil energized in alarm condition (non-failsafe).

Threshold: From 0 to 110% Full Scale (the threshold may be limited due to the selected full scale value).

Hysteresis: Keyboard programmable for each alarm; from 0.1% to 10.0% of span or 1 LSD (whichever is greater) for each alarm.

Filter: Selectable from the following values for each alarm:

OFF, 0.4S, 1S, 2.5S, 3S, 4S, 5S.

Alarm Update Time: At every input conversion.

2.9 Optional Serial Communication Interface Specification

Serial Interface: RS-485 type. Opto-isolated.

Protocol Type: Modbus/Jbus (RTU mode).

Type of Parameters: Run-time and configuration are available by serial link.

Device Address: From 1 to 255

NOTE: The physical interface can only support up to 31 devices for each segment. Use multiple segments for more than 31 devices.

Baud Rate: 600 up to 19200 baud.

Format: 1 start bit, 8 bits with/without parity. 1 stop bit

Parity: Even/Odd.

2.10 Main Analog Output Specification

Main Analog Output: Opto-isolated from CPU input and output circuits.

Type of Output Function: Keyboard selectable as

- Primary input retransmission
- Secondary input retransmission

Type of Analog Output: Keyboard selectable between:

- +0/10Vdc min. load 5 K Ω , with under/over range capability from -2.5 to 12.5V
- -10/+10Vdc mm. load 5K Ω , with under/overrange capability from -12.5 to 12.5V
- +0/5Vdc mm. load 5K Ω , with under/overrange capability from -1.25 to 6.25V
- +0/20mA max. load 500 Ω , with under/over range capability from -5 to 25mA (max. load 400 Ω over 2mA).
- -4/20mA max. load 500 Ω , with under / over range capability from 0 to 24mA (max. load 400 Ω over 20mA).

2.11 Second Analog Output Specification

Second Analog Output: Opto-isolated from CPU input and output circuits.

Type of Output Function: Keyboard selectable for:

- Primary input retransmission
- Secondary input retransmission

Type of Analog Output: Keyboard selectable between:

- +0/10Vdc min. load 5K Ω , with under/over range capability from -2.5 to 12.5V
- +0/5Vdc min. load 5 K Ω , with under/over range capability from -1.25 to 6.25V
- +0/20mA max. load 500 Ω , with under/over range capability from 0 to 24mA (max. load 400 Ω over 20mA).
- +4/20mA max. load 500 Ω , with under/over range capability from 0 to 24mA (max. load 400 Ω over 20mA).

2.12 Primary & Secondary Analog Outputs Common Specification

Resolution: 0.1% of output span.

Reference Accuracy: $\pm 0.1\%$ of output span @ $25 \pm 1^\circ\text{C}$ and nominal line voltage.

Linearity Error: $<0.1\%$ of output span.

Output Noise: $<0.1\%$ of output span.

Scaling: The retransmission low and high limits are selectable from 0 to primary input full-scale value (when the retransmitted variable is primary input) or from low to high secondary limits (when the retransmitted variable is the secondary input). The two scaling values may be freely selectable within the above range. This allows having a direct or reverse output type.

Output Filter: Selectable: OFF, 0.4S, 1S, 2S, 3S, 4S, 5S

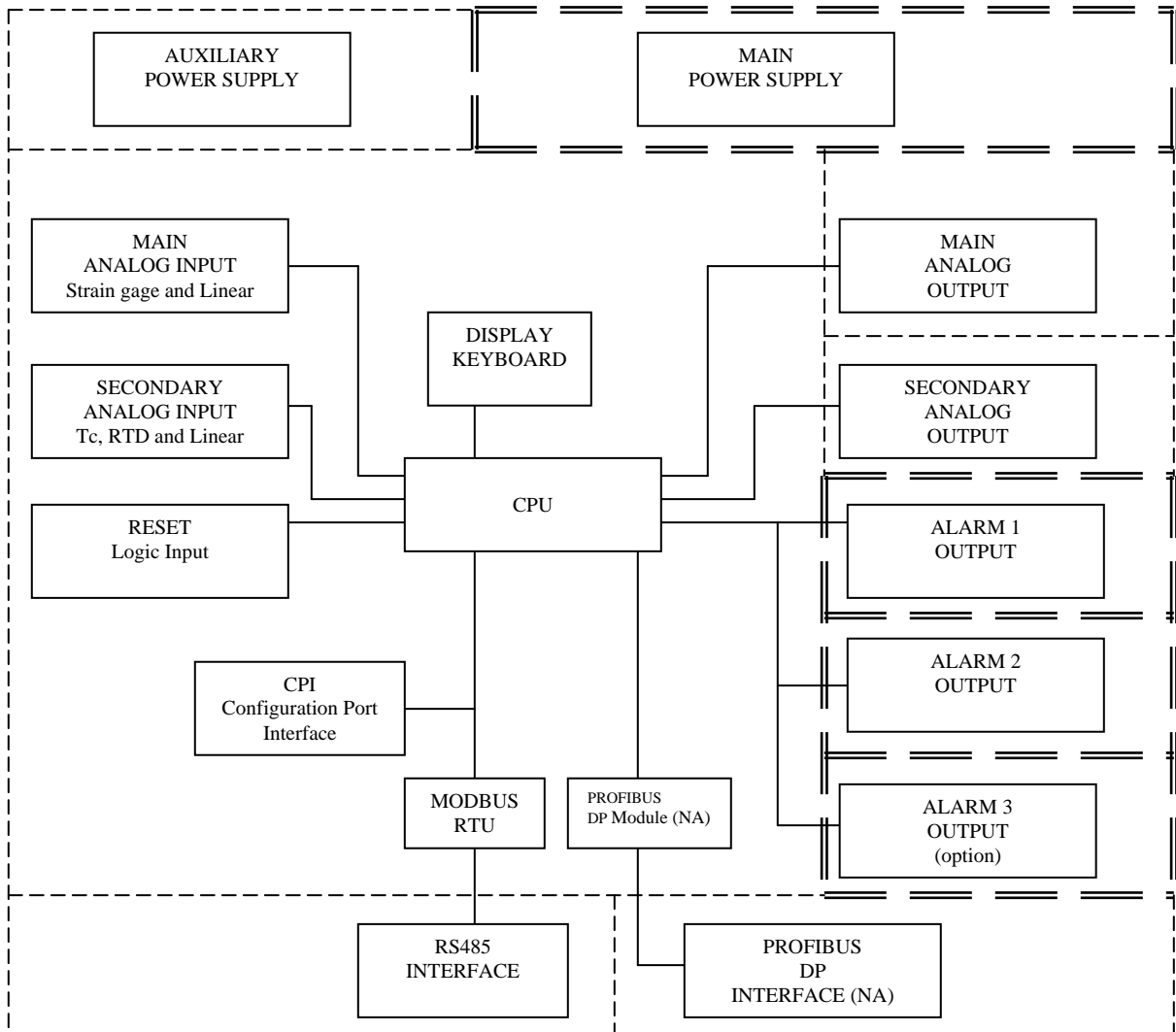

NOTE: Dashed Line represents insulation boundary.
 Double Dashed Line represents reinforced insulation boundary.

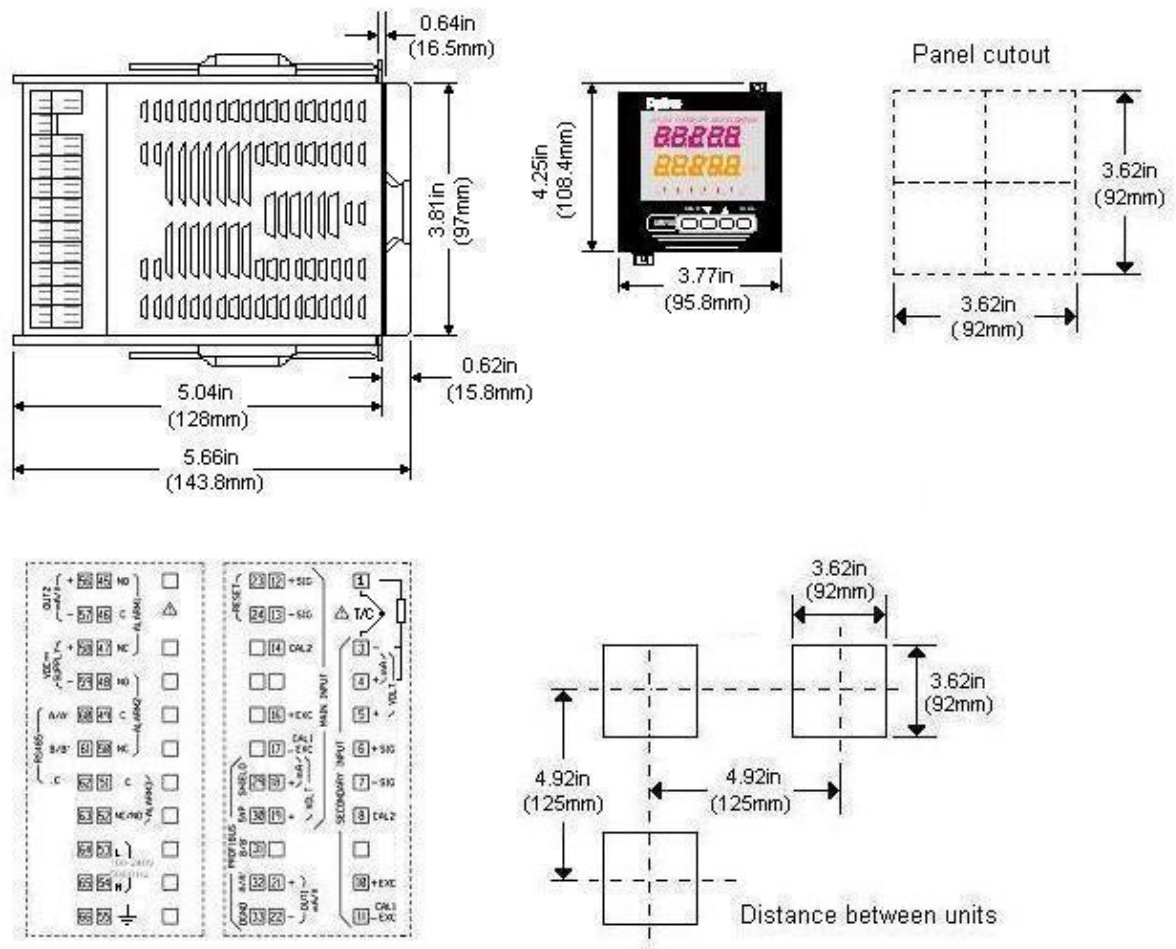

All dimensions are in inches (millimeters) unless otherwise specified

Figure 2. Model UPR800 Outline Drawing

3.0 UNPACKING

Upon receipt, examine package for shipping damage. Notify the carrier immediately in the event of any evidence of damage, and retain shipping materials for their inspection.

This package should contain the instrument and two panel mounting brackets.

4.0 DIMENSIONAL INFORMATION

Dimensions: 3.78" X 3.78" X 6.01" overall (96mm X 96mm X 143.5mm)

Cutout: 3.62" X 3.62" (92mm X 92mm)

Depth behind panel: 5.04" (128mm)

Weight: 1.43 lbs. (650g)

5.0 HARDWARE

The UPR800 is shipped configured for the following:

- Primary Input (Pressure) - Strain Gage
- Optional Secondary Input - Thermocouple
- Main Output - Voltage
- Optional Secondary Output – Voltage
- Security lock is OFF

Please refer to the drawings in the appropriate sections to determine the configuration for input(s) and output(s) used in your particular application. It is necessary only to select the category (e.g. Voltage or Current). The specific range will be chosen in the software menu.

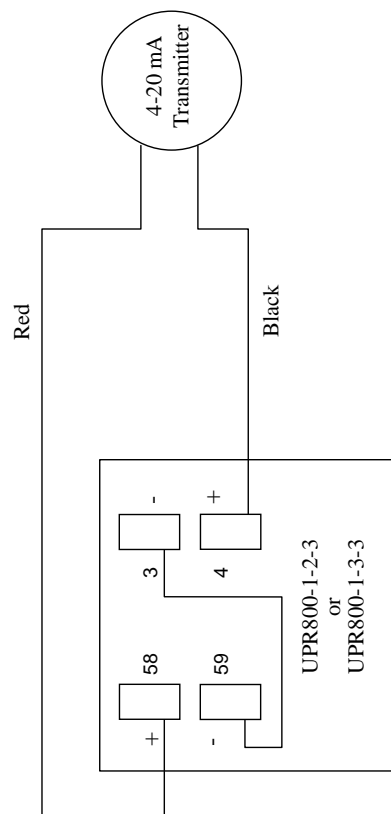

Figure 4. UPR800 Wiring – 4-20 mA Transmitter
Internal 24 VDC Power Supply – Secondary Input

6.0 MOUNTING AND WIRING

Please refer to Figure 2 for cutout dimensions and clearance requirements. Locate the two mounting brackets packed with the instrument and have them available.

1. Slide the instrument case into the cutout, being sure that it is right-side-up (terminal 1 at the top). Attach the panel mounting hardware at diagonally opposite sides of the top and bottom of the case, tightening the threaded rod until the case is secure against the panel.
2. Refer to the model number of the instrument to determine the hardware and options included as part of your unit. Please refer to Section 6.1 for the terminal assignments. Terminals are accessed by opening the terminal covers from the side with the “OPEN” legend.

NOTE 1: The UPR800 is equipped with screw terminals, and no connectors are necessary when wiring the unit

NOTE 2: When wiring the alarms, wire to the Common and NO (normally open) terminals to maintain a fail-safe configuration.

Fail-safe denotes a situation where the alarms relay coils are activated in a no-alarm situation. As the relay coil is energized, terminals that are normally open are closed and can cause completion of a circuit when used as an interlock. Should the alarm threshold be exceeded, OR should power be lost to the instrument the contacts will open, and the circuit will be broken. If the alarm is a latching alarm, it will require an external reset signal to be activated again.

If the alarm is used to provide a contact to an alarm device (light, horn buzzer, etc., when the threshold is exceeded, wiring should be to the Common and NC (normally closed) terminals. Activation of the relay coil will cause the contacts to open in a non-alarm situation, and to close if the threshold is exceeded, or power is interrupted to the instrument. If the alarm is a latching alarm, it will require an external reset signal to be activated again.

NOTE 3: Relay Outputs

The contact rating of all outputs is equal to 2A/240 Vac on resistive load.

- To avoid electrical shock, connect power line at the end of the wiring procedure.
- For power connections use No 16AWG or larger wires rated for at least 75°C.
- Use copper conductors only.

NOTE 4: Power Line

Before connecting the instrument to the power line, make sure that the line voltage corresponds to the description on the identification label.

- To avoid electrical shock, connect power line at the end of the wiring procedure.
- For supply connections use No. 16AWG or larger wires rated for at least 75°C.
- Use copper conductors only.
- Don't run input wires together with power cables.
- When a neutral line is present, please connect it to terminal 54.
- For 24Vdc the polarity need not be observed.

The power supply input is fuse protected by a sub miniature fuse rated T, 1A, 250V. When the fuse is damaged, it is advisable to verify the power supply circuit. It is necessary to send back the instrument to Dynisco for service.

The safety requirements for Permanently Connected Equipment say:

- A switch or circuit-breaker shall be included in the building installation;
- It shall be in close proximity to the equipment and within easy reach of the operator
- It shall be marked as the disconnecting device for the equipment.
- A single switch or circuit breaker can drive more than one instrument
- Protective conductor terminals shall be connected to earth.

Terminal Assignments

Terminal	Terminal Assignment - Description	Function category / class	Voltage Rating, V	Current Rating, A	Load type and Rating
1	RTD, T/C +	Secondary Inputs CAT I	2 Vdc	0.001 Adc	
3	RTD, T/C -, mA/V -				
4	mA +, RTD compensation			0.020 Adc	
5	V +		10 Vdc		
6	SIG +	Secondary Input Strain Gage CAT I			From 340Ω to 5000Ω, Excitation 10Vdc ±7% (between EXC + and EXC -)
7	SIG -				
8	CAL2				
10	EXC +				
11	EXC -, CAL1				
12	SIG +	Main Input Strain Gage CAT I			From 340Ω to 5000Ω, Excitation 10Vdc ±7% (between EXC + and EXC -)
13	SIG -				
14	CAL2				
16	EXC +				
17	EXC -, CAL1, mA -, V -				
18	mA +	Main Linear Inputs CAT I		0.020 Adc	
19	V +		10 Vdc		
21	OUT1 mA/V +	Main Analog Retransmission Class 2			±12.5 Vdc min load 5KΩ -5/+25 mA max load 500Ω (max. load 400Ω over 20 mA).
22	OUT1 mA/V -				
23	RESET	Remote Reset of Alarm and/or peak Class 2			Dry Contact switch (voltage free)
24					
29	SHIELD	Standard ProfiBus Communication Class 2			
30	5VP				
31	B/B'				
32	A/A'				
33	DGND				
45	ALARM1 N.O.	Relay contacts used to identify an event (alarm) condition			240 Vac, 2A , resistive
46	ALARM1 C				
47	ALARM1 N.C				
48	ALARM2 N.O.				
49	ALARM2 C				
50	ALARM2 N.C.				
51	ALARM3 C				
52	ALARM3 N.C./N.O.				
53	Line	Main Power Supply	100 – 240 Vac		27VA maximum
54	Neutral				
55	Earth (Ground)				
56	OUT2 mA/V +	Secondary Analog Retransmission Class 2			±12.5Vdc min load 5KΩ. -5/+25 mA max load 500Ω (max. load 400Ω over 20 mA).
57	OUT2 mA/V -				
58	Vdc SUPPLY +	Auxiliary Power Supply Class 2	24 Vdc	0.063 Adc (1.5W)	
59	Vdc SUPPLY -				
60	A/A'	Serial Communication RS485 Class 2			
61	B/B'				
62	C				

Note:

The instrument is not suitable for use with equipment for measurement within measurement categories II, III and IV.

UPR700 to UPR800 Wiring Conversion Table

	UPR800 Terminal	UPR700 Terminal	
Power			
100 - 240Vac	53	53	
Line Neutral	54	54	
Earth (Ground)	55	55	
Transducer			Dynisco Cable Color
Signal (+)	12	12	Red
Signal (-)	13	13	Black
Excitation (+)	16	16	White
Excitation (-)	17	17	Green
CAL 1	17	17	Blue
CAL 2	14	14	Orange
mA (+)	18	12	
V (+)	19	12	
mA/V (-)	17	13	
Alarms			
A1 (N.O.)	45	45	
A1 Common	46	46	
A1 (N.C.)	47	47	
A2 (N.O.)	48	48	
A2 Common	49	49	
A2 (N.C.)	50	50	
Alarm 3 (optional)			
A3 (N.O. / N.C.)	52	52	
A3 Common	51	51	
Analog Output			
mA/V Out (+)	21	21	
mA/V Out (-)	22	22	
2nd Analog Output (optional)			
mA/V Out (+)	56	56	
mA/V Out (-)	57	57	

DYNISCO UPR800 Series Instruction Manual

UPR800 Terminal		UPR700 Terminal	
24 VDC Transmitter Power Supply (optional)			
24 Vdc (+)	58	58	
24 Vdc (-)	59	59	
External Reset Contacts			
Reset	23	23	
Reset Common	24	24	
Second Analog Input (optional)			
Thermocouple Input			
TC (+)	1	1	
TC (-)	3	3	
mA Input			
Input (+)	4	4	
Input (-)	3	3	
V Input			
Input (+)	5	4	
Input (-)	3	3	
RTD Input 3-wire			
Red	1	1	
Black	3	3	
Black	4	4	
Serial Communications (RS485 only)- (optional)			
A	60	60	
B	61	61	
COM	62	62	

7.0 START-UP PROCEDURE

In general, the UPR800 Pressure/Process Indicator is a microprocessor-based instrument, with the capability of monitoring one or two process variables simultaneously. The primary input is configured to accept a 350 Ω Strain Gage, but can be changed to accept high level voltage or current. The primary input full-scale value can be as low as 10, and as high as 99,950 units. The secondary input, if supplied, will accept a "J" type thermocouple, but can be changed to most thermocouples or RTD's, or to a high-level voltage or current. The secondary input full-scale value can be as low as -1,000 and as high as 3,000 units.

The standard UPR800 has 2 SPDT dry contact closure alarms, with an optional third alarm. In addition, it has one or two scalable analog retransmission outputs, or RS-485 communications.

Alarm 1 is configured as a High Alarm at 40% of the full-scale transducer value, with 0.4 second filtering, 1.0% hysteresis, Auto reset, failsafe mode, and it is linked to the primary input.

Alarm 2 is configured as a High Alarm at 60% of the full-scale value, with 0.4 second filtering, 1.0% hysteresis, Auto reset, failsafe mode, and is also linked to the primary input,

Alarm 3, if supplied, is configured as a High Alarm at 80% of the full-scale value, with 0.4 second filtering, 1.0% hysteresis, Auto reset, failsafe mode, and it is disabled (not linked to any input),



These terms will be described in the **ALARMS** section.

7.1 Getting Ready:

1. Slide the case into the panel cutout. **MAKE SURE TERMINAL 1 IS AT THE TOP!** Attach the panel mounting hardware at diagonally opposite sides of the top and bottom of the case, tightening the threaded rod until the case is secure against the panel.
2. Attach the primary and secondary devices, (if supplied) and wire according to the terminal assignments.

7.2 Configuring the UPR800:

Apply power to the cabinet. The upper display will show a reading near zero, and the lower display will show the current temperature or PEAK if the unit does not have secondary input. It may display OPEN if there is no transducer connected, or if the transducer is amplified.

The keys on the UPR800 must be pressed and released to move about in the configure screens. Do not press and hold a key unless told to do so; simply press the key and release it to advance to the next screen. The arrow keys  or  may be held down to advance rapidly through the values.

7.3 Keyboard Description:

The keyboard is composed of four push buttons, covered by a silicone protective operator, labeled , , **FUNC** and **RESET**.



The  is called the “Down Arrow Key”, and is used to increment and decrement the parameter value.

The  is called the “Up Arrow Key”, and is used to increment and decrement the parameter value. It also may be used to switch the lower display from the secondary input (if available) to the peak value (if enabled) and back again. At power up, the lower display shows the secondary input value (if present) or it shows the peak value. If there is no secondary input and the peak value is disabled, the lower display is blank.

The **FUNC** (“function”) key is used to access the parameter to view, modify, and enter the “Operating Mode Switching” procedure (when pressed for more than 7 seconds).

The **RESET** key is used to reset the stored peak value and to reset the alarms when held for 1 second, (once the alarm condition has cleared beyond the hysteresis value). This function is disabled when the device is controlled by the serial link. In addition, when checking or changing parameters, it is used to return to the normal display mode without storing the parameter change.

Pressing  then **RESET** together, or  then, may be used to jump to maximum or minimum parameter values when the instrument is in function mode.

At power up, if the instrument detects a parameter error, the upper display shows **ERR #**, (where **#** is the error number), and the lower display will show the parameter name. If the wrong parameter is a run-time parameter (i.e. **AL 1** to **SO.TYP**) pressing the  then  together will cause the instrument to load the default values for all parameters.

If the wrong parameter is a calibration or code parameter, pressing the **FUNC** then **RESET** keys together, enables the instrument to access the run-time parameters. This function is intended only to restore a misplaced parameter’s value; however, the performance of the instrument is not guaranteed. The user is advised to check the stated parameter.

NOTE: All the actions explained above that require two or more pushbuttons, must follow the pushbutton sequence exactly.

7.4 Operating Mode Description:

The **FUNC** key is used to access the parameters organized in five groups. Use the **FUNC** pushbutton to access the Group 1 parameters; the last entry (showing **Group** and

None is intended to access the other groups of parameters, or pressing **FUNC** again returns to the normal display mode. Each group has its own family of parameters, loosely grouped around the decreasing need to change the parameters. Each group also has the ability to load its own default parameters and the default values of the lower number groups.

8.0 CONFIGURATION

8.1 Parameters

The UPR800 parameters are grouped in five sections guarded by three security levels. The more common parameters are in the first groups, with the higher Group numbers for those parameters an operator would not normally modify. Each group can be reset to its default value by two keystrokes. This also resets the parameters of any lower numbered group to default. If GROUP 5 is set to default, the entire instrument is reset to its default parameters. If a unit does not have a particular option, its parameters will not appear. For example, an instrument that does not have RS-485 communications will skip those parameters related to communications. Likewise, if a particular function is turned off, its other parameters will not appear. For example, if Alarm 2 is turned to **OFF** in Group 3, the hysteresis, reset, filter, type, and threshold functions will not appear on screen. Nor will the alarm appear on the bar graph display.

When the instrument is turned on, it will go through a self-test during which the front panel will illuminate. The instrument will then be in the normal display mode showing the value of the main input on the upper display, and the value of the secondary input on the lower display (if so equipped). If there is no secondary input, the lower display will show the maximum peak value of the main input. In the event that no input device is connected, both displays will show **OPEn**. If no secondary input is present, the lower display will show **OPEn** indicating that the unit failed to full scale, the bar graph display will be at 100% with the last segment flashing. Turn the power to the instrument off and connect an input device to the appropriate terminals, and connect a thermocouple or appropriate signal source to the secondary input terminals (if supplied). Upon turning the instrument back on, the displays should have a numeric value, close to zero pressure on the pressure display, and near room temperature on the thermocouple display. Depressing **FUNC** will go automatically into the GROUP 1 parameters.

Successively pressing **FUNC** will scroll through all the parameters of GROUP 1. The last two parameters of each group allow the default parameters to be restored, and returns to **GROUP**. If **nonE** is chosen in the group access function, the instrument will return to normal operating mode after pressing of the **FUNC** key.

When in GROUP 1, if no keyboard activity is detected for approximately 10 seconds, the instrument will automatically return to the normal display mode.

8.2 Parameter Configuration Procedures

The parameters in the five groups are extensive, and not all parameters need to be addressed. While they are fully explained in the following section, it would be well to review them prior to configuring the instrument in your application. It is entirely possible that only a minimum number of parameters need to be adjusted to have your process operating satisfactorily. Please note that at any time, the default parameters may be reset to the factory settings. Each parameter group can be reset at any time, (which also resets the levels with numbers higher than the selected group). To set a default level, press the **FUNC** key until **DEFLT** shows on the lower display and **OFF** shows on the

upper display. Press the **▼** or **▲** key until **ON 1** shows in the upper display. Press the **FUNC** key to load all of the factory parameters for groups 1, 2, 3, 4, and 5.

To reset a specific group (and higher numbered groups) to the default factory settings, press the **FUNC** key until **nonE** and **GROUP** show on the display. Press the **▲** key until the appropriate group number appears in the upper display. . Press the **FUNC** key to enter the appropriate group. Press the **FUNC** key until **DEFLT** shows on the lower display and **OFF** shows on the upper display. Press the **▼** or **▲** key until **ON #** (where # is the Group number). Press the **FUNC** key to load the factory parameters for that groups (and higher numbered groups).

8.2.1 Setting the Logic Input Configuration (if supplied)

If the unit does not have the logic input option, skip to Section 8.3.3.

The Logic Input can be off, can be set to function as an alarm reset, a peak reset, or it can reset both. To verify this parameter or to change it, press the **FUNC** key until **nonE** and **GROUP** show on the display. Press the **▲** key until **4** shows in the upper display. Press the **FUNC** key until the lower display shows **LI.TYP**. Press the **▼** or **▲** key until the upper display shows the correct selection: **OFF**, **AL** - alarms reset, **P** - Peak reset or **AL-P**, Alarm & Peak reset), **CAL.0**, Remote Zero Cal, **ALL**, AL+P+CAL.0). Press the **FUNC** key to set the value and move to the next parameter, or press the **RESET** key to go back to the active display.

8.2.2 Setting the Logic Input Status (if supplied)

The Logic Input Status can be off, can be set to function as an alarm reset, a peak reset, or it can reset both. To verify this parameter or to change it, press the **FUNC** key until **nonE** and **GROUP** show on the display. Press the **▲** key until **4** shows in the upper display. Press the **FUNC** key until the lower display shows **LI.STS**. Press the **▼** or **▲** key until the upper display shows the correct selection: **CLOSE**, or **OPEN**.

Press the **FUNC** key to set the value and move to the next parameter, or press the **RESET** key to go back to the active display.

8.2.3 Setting Peak Detection

The Peak Detection can be either set to OFF, the default value of HIGH, or to LOW. To verify this parameter or to change it, press the **FUNC** key until **nonE** and **GROUP** show on the display. Press the **▲** key until **4** shows in the upper display. Press the **FUNC** key until the lower display shows **PEAK**. Press the **▼** or **▲** key until the upper display shows the correct value (**OFF**, **HI**, or **LO**). Press the **FUNC** key to set the value and move to the next parameter, or press the **RESET** key to go back to the active display.

8.2.4 Setting the Line Frequency

The Line Frequency default value is Auto. To verify this parameter or to change to 50 Hz, press the **FUNC** key until **nonE** and **GROUP** show on the display. Press the **▲** key until **4** shows in the upper display. Press the **FUNC** key until the lower display shows **LINE.F**. Press the **▼** or **▲** key until the upper display shows the correct frequency. Press the

FUNC key to set the value. Press the **FUNC** key to set the value and move to the next parameter, or press the **RESET** key to go back to the active display. When set to Auto, Group 4 Parameter LINE.R displays the detected Line Frequency.

8.2.5 Setting the Display Filter

Filtering is an electrical method of averaging the displayed values over a period of time to arrive at a more legible display. Filtering helps to eliminate short duration transients and spikes that may cause false or spurious readings.

To change or view the Main Analog Output Filter, press the **FUNC** key until **nonE** and **GROUP** show on the display. Press the **▲** key until **2** shows in the upper display. Press the **FUNC** key until the lower display changes to **DSP.FL**. Using the **▼** or **▲** keys, select the amount of filtering desired, from none (**OFF**) to five seconds. When finished, press the **FUNC** key to lock in the value and advance to the next parameter.

GROUP #	FUNCTION	MNEMONIC	CHOICES	DEFAULT
Group 5	Primary Input Selection	PI.TYP	Str, 0-20, 4-20, 0-5, 0-10	Str
Group 5	Secondary Input Selection	SI.TYP	OFF, tc, rtd, 0-20 4-20, 0-10, str	Tc
Group 4	Shunt Calibration	SHUNT	OFF, On	On
Group 4	Shunt Value	SHNT%	40.0 TO 100.0%	80.0%
Group 3	Input Full Scale Value	PI.FSV	10 TO 99950	10000
Group 3	Input Low Scale Value	PI.LSV	± 25% OF SFV OF FS V	0
Group 3	Input Decimal Point Position	PI.DP	None, 1,2,3,4 places	None
Group 3	Secondary Input T/C Type	SI.TC	tc J, tc CA, tc L, tc n	tc J
Group 3	Alarm 1 Input Channel Link	AI.LNK	OFF, Prl.In, Sec.In	Prl.In
Group 3	Alarm 1 Type	AI.TYP	HI, LO, Inhib	HI
Group 3	Alarm 2 Input Channel Link	A2.LNK	OFF, Prl.In, Sec.In	PrLIn
Group 3	Alarm 2 Type	ALTYP	HI, 10, Inhib	HI
Group 2	Zero Calibration	ZERO.C	OFF, On, CLEAR	OFF
Group 2	Span Calibration	SPAN.C	OFF, On, CLEAR	OFF

Group 1	Alarm 1 Threshold	AL1	TO 110%of span	40% of range of related input
Group 1	Alarm 2 Threshold	AL2	TO 110% of span	60% of range of related input

In this example, these are functions necessary to allow operation of a pressure/temperature indicator with two high alarms.

8.3 Primary Input Setup

8.3.1 Setting the Primary Input Type for a Strain Gage Transducer

If using a **Dynisco** transducer, the model number of the transducer will designate its own electrical output. For example, in plastic melt applications, the PT462E-5M-6/18 or TPT432A-10M-6/18 have a strain gage (0-3.33 mV/V dc full scale) signal output. Amplified units have a number where the strain gage units have a letter (E or A). The PT4624-5M-6/18 has a 4-20mA signal output; the PT4625-5M-6/18 has a 0-5 Vdc signal output, while PT4626-5M-6/18 has a 0-10Vdc signal output. In Industrial applications, amplified units have a middle or end number of 4, 5, or 6. The S840-000-1C has a 4-20mA signal output; the PT150-7.5M has a 0-5Vdc signal output, while PT276-5M has a 0-10Vdc signal output.

If you have an amplified transducer, or other amplified input, skip this section.

The UPR800's default setting is strain gage input. To verify that the input is set for strain gage, press the **FUNC** key until **nonE** and **GROUP** show on the display. Press the **▲** key until **5** shows in the upper display. Press the **FUNC** key and the upper display should show **Str** while the lower display shows **PI.TYP**. If not, press the **▼** or **▲** key until the upper display changes to **Str** (for strain gage). Press the **FUNC** key to set the value. The upper display changes to **tc** with **SI.TYP** on the lower display. Press the **RESET** key to return to the active display.

8.3.2 Setting the Shunt Calibration for Strain Gage Transducers and Amplified units

The Dynisco strain gage transducers and amplified transmitters (if so equipped) have an internal shunt to allow the UPR800 to set the span full scale value automatically. To Access the Shunt Calibration parameter, press the **FUNC** key until **nonE** and **GROUP** show on the display. Press the **▲** key until **4** shows in the upper display. Press the **FUNC** key and the upper display will show **OFF** while the lower display shows **SHUNT**. Press the **▼** or **▲** key until the upper display changes to the **ON**. Press the **FUNC** key to set the value and move to the next Shunt parameter.

The upper display will show **80.0** while the lower display shows **SHNT%**. In most cases, the Dynisco transducers have an 80% shunt value so no changes need be made. However, some transducers and strain gages have shunt values that may range from 40-100%. If so, press the **▼** or **▲** key until the upper display changes to the correct values.

Press the **FUNC** key to set the value. Press the **RESET** key to go back to the active display.

8.3.3 Setting the Primary Input Type for an Amplified Transmitter

If using a voltage or current output transducer, the model number of the transducer will designate its own electrical output. For example, a PT4624-7.5M-6/18 or an S840-000-10M has an amplified signal output. In plastic melt applications, amplified units have a number where the strain gage units have a letter (E or A). The PT4624-7.5M-6/18 has a 4-20mA signal output; the PT4625-7.5M-6/18 has a 0-5Vdc signal output, while PT4626-7.5M-6/18 has a 0-10Vdc signal output. In Industrial applications, amplified units have a middle or end number of 4, 5, or 6. The PT140 has a 4-20mA signal output; the PT150-7.5M has a 0-5Vdc signal output, while PT276-5M has a 0-10Vdc signal output. NOTE: If using 0-10V transmitter, do not connect RCal leads to terminals 14 & 17.

If you have a strain gauge transducer, load cell, or other mV/V device, see other section.

The Instrument's default setting is strain gage input. To select another input for a transmitter or to use another process instrument, such as humidity sensors, position sensors, etc., press the **FUNC** key until **nonE** and **GROUP** show on the display. Press the **▲** key until **5** shows in the upper display. Press the **FUNC** key and the upper display will show **Str** while the lower display shows **PI.TYP**. Press the **▼** or **▲** key until the upper display changes to the correct value (**0-20** for 0-20 mA linear input, **4-20** for 4-20 mA current loop input, **0-5** for 0-5Vdc linear input, and **0-10** for 0-10Vdc linear input. Press the **FUNC** key to set the value. Press the **RESET** key to go back to the active display.

Remember to change software configuration to correspond to the proper input.

8.3.4 Setting the Primary Input Full-Scale Value

The model number of the transducer or transmitter will designate the full-scale pressure capability. For example, model number TPT432A-5M-6/18 indicates that the full-scale pressure is 5,000 (5M), while the PT150-5C indicates that the full-scale pressure is 500 (5C). Since the default value in the instrument is 10,000 full scale, the input full-scale value must be changed to 5,000 (or 500). Note that there are no units here, it can be psi, bar, mPa, kg/cm² or any engineering unit; the magnitude is all that is important. To set the full-scale value, press the **FUNC** key until **nonE** and **GROUP** show on the display. Press the **▲** key until **3** shows in the upper display. Press the **FUNC** key and the upper display will show **10000** while the lower display shows **PI.FSV**. Hold the **▼** or **▲** key until the upper display changes to **5000** (or whatever the full-scale value of the primary input may be). Press the **FUNC** key to set the value. Check that the next display reads **0** in the upper display and **PI.LSV** in the lower display; if not, set to zero with the arrow keys and press **FUNC** to lock in the value. Finally, press the **RESET** key to go back to the active display. Similarly, if the full-scale pressure is 350 Bar (3.5CB), set **PI.FSV** to 350.

8.3.5 Setting the Primary Input Low-Scale Value

For applications where a low scale value is non-zero, the Instrument can provide a low scale value of $\pm 25\%$ of the full scale value.

To set the low-scale value, press the **FUNC** key until **nonE** and **GROUP** show on the display. Press the **▲** key until **3** shows in the upper display. Press the **FUNC** key and the upper display will show a value while the lower display shows **PI.SFV**. Press the **FUNC** key and the upper display will show **0** while the lower display shows **PI.LFV**. Hold the **▼** or **▲** key until the upper display changes to whatever the low-scale value of the primary input may be. Press the **FUNC** key to set the value. Finally, press the **RESET** key to go back to the active display.

8.3.6 Setting the Primary Input Decimal Place

To set the decimal place, press the **FUNC** key until **nonE** and **GROUP** show on the display. Press the **▲** key until **3** shows in the upper display. Press the **FUNC** key until the lower display shows **PI.DP**. Press the **▼** or **▲** key until the upper display shows the correct decimal place location. Press the **FUNC** key to set the value. Finally, press the **RESET** key to go back to the active display.

8.3.7 Setting the Primary Input Failsafe Mode

The Primary Input Failsafe Mode is nothing more than a safety mechanism that tells the instrument what to do in the event of a loss of the primary signal. If the system is set up to shut down the process in a high alarm condition, the Primary Input Failsafe parameter sets the value of the primary input to full scale if it loses the primary signal. If the system is set up to shut down the process in a low alarm condition, the Primary Input Failsafe parameter sets the value of the primary input to low scale if it loses the primary signal. The default Primary Input Failsafe Mode is to set the value to full scale high.

To set the Primary Input Failsafe Mode, press the **FUNC** key until **nonE** and **GROUP** show on the display. Press the **▲** key until **4** shows in the upper display. Press the **FUNC** key until the lower display shows **PI.IFS**. Press the **▼** or **▲** key until the upper display shows the correct mode, either **HI** or **Lo**. Press the **FUNC** key to set the value. Finally, press the **RESET** key to go back to the active display.

8.4 Secondary Input Setup

Skip this section if there is no secondary input or if this is a new installation and the secondary input is for a “J” type thermocouple expressed in degrees Fahrenheit (°F).

8.4.1 Setting the Secondary Input Type

The Secondary Input measured values will show in the lower display. The Instrument's default secondary input setting is for a “J” type thermocouple. To select another type of input, press the **FUNC** key until **nonE** and **GROUP** show on the display. Press the **▲** key until **5** shows in the upper display. Press the **FUNC** key twice and the upper display will show **tr** while the lower display shows **SI.TYP**. Press the **▼** or **▲** key until the upper display changes to the correct value (**rtd** for Platinum RTD, **0-20** for 0-20 mA linear input, **4-20** for 4-20mA current loop input, **0-10** for 0-10Vdc linear input, and **OFF** if the input is to be disabled. Press the **FUNC** key to set the value. Finally, press the **RESET** key to go back to the active display.

Remember to change software configuration to correspond to the proper input.

8.4.2 Setting the Secondary Input Scale and Decimal Point

Skip to “Setting the Thermocouple Type and Units” if the secondary input is for an RTD or a thermocouple.

If the Instrument’s secondary input is set as a voltage or current, the Range Values need to be set. Press the **FUNC** key until **nonE** and **GROUP** show on the display. Press the **▲** key until **3** shows in the upper display. Press the **FUNC** key and the upper display will show the full scale value while the lower display shows **SI.FSV**. Press the **FUNC** key until the lower display changes to **SI.LO**. Using the **▼** or **▲** keys, enter the zero value for the input. For example if the input from a device is 500-3,000 units, it is 500 units at zero, so enter 500. Press the **FUNC** key to set the value. The lower display will change to **SI.HI**. Using the **▼** or **▲** keys, enter the high (full-scale) value for the input. For example if the input from a device is 500-3,000 units, it is 3,000 units at full scale, so enter 3000. Press the **FUNC** key to set the value. The lower display will change to **SI.DP**, the decimal point position for the secondary input. Using the **▼** or **▲** keys, select the position for the decimal point for this input and press **FUNC** to lock in the value. Finally, press the **RESET** key to go back to the active display.

8.4.3 Setting the Thermocouple Type and Units:

If the secondary input is from a thermocouple, set the thermocouple type and temperature units, by pressing the **FUNC** key until **nonE** and **GROUP** show on the display. Press the **▲** key until **3** shows in the upper display. Press the **FUNC** key until the lower display shows **SI.TC**. Press the **▼** or **▲** key until the upper display changes to the correct value (**tc j** for type “J”, **tc CA** for type “K”, **tc L** for type “L”, and **tc n** for a type “N” thermocouple). Press the **FUNC** key to set the value. The upper display changes to **FAhr** (for Fahrenheit) while the lower display shows **SI.C/F**. Press the **▼** or **▲** key to change to Celsius **CEL** or if desired.

These inputs are factory pre-calibrated for the following ranges, and require no further calibration.

Thermocouple	Type J	-200 to 800°C	-328 to 1472°F
	Type K (CA)	-200 to 1200°C	-328 to 2192°F
	Type L	-200 to 800°C	-328 to 1472°F
	Type N	0 to 1300°C	32 to 2372°F
	Type T	-200 to 400°C	-328 to 752°F
	Type E	-200 to 600°C	-328 to 1112°F
RTD	Pt100	-200 to 600°C	-328 to 1112°F
	Pt500	-200 to 600°C	-328 to 1112°F

8.4.4 Setting the Secondary Input Failsafe Mode

The Secondary Input Failsafe Mode is a safety mechanism that tells the instrument what to do in the event of a loss of the Secondary signal. In the event of a Secondary input

signal loss, the Secondary Input Failsafe parameter sets the value of the primary input to full scale (in the default mode).

To set the Primary Input Failsafe Mode, press the **FUNC** key until **nonE** and **GROUP** show on the display. Press the **▲** key until **4** shows in the upper display. Press the **FUNC** key until the lower display shows **SI.IFS**. Press the **▼** or **▲** key until the upper display shows the correct mode, either **HI** or **Lo**. Press the **FUNC** key to set the value. Finally, press the **RESET** key to go back to the active display.

8.5 Setting the Alarms:

All Alarms supplied with the Instrument can be linked to either the Primary Input or the Secondary Input (if available), and are capable of being set as High Level Alarms or Low Level Alarms, and may operate in either *Failsafe* or *Direct* condition.

Failsafe means that in the event of power failure to the Instrument, the Alarm will activate. Use this feature on a shutdown alarm. Please note that in a proper operating condition in Failsafe mode, the Normally Closed Contact are held OPEN, while the Normally Open contacts are held CLOSED. On power failure, they are released.

On start-up, a Low Alarm may cause the unit to go into an undesired alarm condition prior to reaching running conditions. This Alarm can be masked so that the Low Alarm will be deactivated until it has gone above the alarm value for the first time. It will then operate as a normal low alarm.

The default values for **Alarm 1** are: high alarm at 40% of full scale, linked to the primary input, 0.4 second filtering, 1% hysteresis, automatic reset, and failsafe mode. Each alarm may be set to 110% of full scale.

The default values for **Alarm 2** are: high alarm at 60% of full scale, linked to the primary input, 0.4 second filtering, 1% hysteresis, automatic reset, and failsafe mode.

The default values for **Alarm 3**, if supplied, are: high alarm at 80% of full scale, disabled (not linked to any input), 0.4 second filtering, 1% hysteresis, automatic reset, and failsafe mode.

Set the Alarm parameters before setting the alarm value. If the alarm parameters have already been set, set the alarm values as described in section 8.6.7.

8.5.1 Setting Channel Alarm to Monitor (Alarm Input Channel Link):

The Alarm 1 Input Channel Link defaults to the primary input. To check or change this value press the **FUNC** key until **nonE** and **GROUP** show on the display. Press the **▲** key until **3** shows in the upper display. Press the **FUNC** key until **A1.LNK** shows in the lower display. Select the choice desired by pressing the **▼** or **▲** keys. The choices are: **OFF**, (disabled), linked to the primary input **Pri.In**, or linked to the secondary input **Sec.In**. Note: if you do not have a secondary input, **Sec.In** will not appear as a choice. Press the **FUNC** key to lock in the value and advance to the next parameter. Similarly, you may configure Alarm 2 (**A2.LNK**) and if supplied, Alarm 3 (**A3.LNK**).

8.5.2 Setting Alarm Type:

A high alarm will activate when a set point is exceeded. A low alarm will activate whenever the value falls below a set point (including startup). An inhibited low alarm must exceed the low alarm set point before it is enabled. Then it will work like a low alarm. This is ideal on startup.

The default alarm type for Alarm 1 is high. To check or change this value press the **FUNC** key until **nonE** and **GROUP** show on the display. Press the **▲** key until **3** shows in the upper display. Press the **FUNC** key until **A1.TYP** shows in the lower display. Using the **▼** or **▲** keys, select **HI** for high level alarm, **LO** for low level alarm or **Inhib** for a low level alarm with mask at start-up. Press the **FUNC** key to lock in the value and advance to the next parameter. If finished, press **RESET** to return to the operating screen. Similarly, you may configure Alarm 2 (**A2.TYP**) and if supplied, Alarm 3 (**A3.TYP**).

8.5.3 Setting the Filtering for Alarm 1:

Filtering is an electrical method of averaging the input values over a period of time to arrive at a smoother curve. This helps to eliminate short duration transients and spikes which can cause alarms, but which may cause false or spurious readings.

The Alarm filter default is 0.4 seconds of filtering. To change this value, press the **FUNC** key until **nonE** and **GROUP** show on the display. Press the **▲** key until **2** shows in the upper display. Press the **FUNC** key until the lower display changes to **A1.FL**. Using the **▼** or **▲** keys, select the amount of filtering desired, from none (**OFF**) to five seconds. When finished, press the **FUNC** key to lock in the value and advance to the next parameter. If finished, press **RESET** to return to the operating screen. Similarly, you may configure Alarm 2 (**A2.FL**) and if supplied, Alarm 3 (**A3.FL**).

8.5.4 Setting the Hysteresis for Alarm:

Hysteresis is used to describe the amount that the reading must drop below the alarm point (in a high alarm) or must rise above the alarm point (in a low alarm) to clear the alarm condition. This helps to eliminate short duration alarms when operating near the alarm condition. To change or view this value, press the **FUNC** key until **nonE** and **GROUP** show on the display. Press the **▲** key until **4** shows in the upper display. Press the **FUNC** key until the lower display changes to **A1.HYS**. The values for hysteresis can range from 0.1% to 10.0%. Press the **▼** or **▲** keys until the upper display changes to the desired value. Press the **FUNC** key to lock in the value and advance to the next parameter, or press **RESET** to return to the operating screen. Similarly, you may configure Alarm 2 (**A2.HYS**) and if supplied, Alarm 3 (**A3.HYS**).

8.5.5 Setting the Reset Mode for Alarms:

The Alarm Reset Mode determines if the alarm resets itself once the alarm condition is been corrected, or whether the operator must press a button to reset the alarm. The Alarm Reset Mode default is automatic reset once the alarm has cleared. To change or view this value, press the **FUNC** key until **nonE** and **GROUP** show on the display. Press the **▲** key until **4** shows in the upper display. Press the **FUNC** key until the lower display changes to **A1.RES**. The values for reset mode is either **Auto** for automatic reset, or

LAtCH for manual reset. Press the ▼ or ▲ keys until the upper display changes to the desired value. Press the **FUNC** key to lock in the value and advance to the next parameter, or press **RESET** to return to the operating screen. Similarly, you may configure Alarm 2 (**A2.RES**) and if supplied, Alarm 3 (**A3.RES**).

8.5.6 Setting the Failsafe Mode for Alarms:

The Alarm Failsafe Mode determines how the alarms react in the event of a power failure to the UPR800. In the failsafe mode, the alarms will activate in the event of power loss. In non-failsafe mode they **cannot** activate in the event of power loss. The Alarm failsafe mode default is failsafe mode. To change or view this value, press the **FUNC** key until **nonE** and **GROUP** show on the display. Press the ▲ key until **4** shows in the upper display. Press the **FUNC** key until the lower display changes to **A1.FSM**. The options for failsafe mode are either **FS** for failsafe mode, or **nFS** for non-failsafe mode. Press the ▼ or ▲ keys until the upper display changes to the desired value. Press the **FUNC** key to lock in the value and advance to the next parameter, or press **RESET** to return to the operating screen. Similarly, you may configure Alarm 2 (**A2.FSM**) and if supplied, Alarm 3 (**A3.FSM**).

Please note that the wiring must be considered: For failsafe operation the alarm contacts must be wired differently to have operation as expected. This is because the UPR800 holds the contact relay in an energized state during normal operation. In the event of an alarm condition or the loss of power to the UPR800, the relay will be de-energized and will then open. The same holds true for a NC contact. It will be held OPEN during normal operation. In the event of an alarm condition or the loss of power to the UPR800, the relay will be de-energized and will then close.

8.5.7 Setting the Alarms Value (Alarms Threshold):

The Alarm 1 Threshold Values, is the value beyond which the Alarm will activate (i.e. the threshold). Alarm 1 is set in the same engineering units that the Full Scale Value uses. To change or view this value when in the operating screen, press the **FUNC** key, when in the main screen, and the lower display will change to **AL1** with the threshold value in the upper display. Press the ▼ or ▲ keys until the upper display changes to the desired value. Press the **FUNC** key to lock in the value and advance to the next parameter, or press **RESET** to return to the operating screen. Similarly, you may configure Alarm 2 (**AL2**) and if supplied, Alarm 3 (**AL3**).

8.5.8 Setting the Alarms Mask Reset Type:

The Alarm 1 Mask Reset may only be used on alarms configured as inhibited Low Alarms on startup. It prevents the alarm from activating (masks the alarm) until the value of the primary input exceeds the alarm value. To change or view this value when in the operating screen, press the **FUNC** key until the lower display changes to **AL.MSK** with **OFF** in the upper display. Press the ▼ or ▲ keys until the upper display changes to **rESet**. Press the **FUNC** key to lock in the value and advance to the next parameter, or press **RESET** to return to the op screen. You may similarly configure Alarm 2 and if supplied, Alarm 3.

8.6 Main Analog Output Setup

This set of parameters will only be available for units that include an active secondary input (**SI.TYP** other than **OFF**); otherwise it defaults to the primary input.

8.6.1 Setting the Main Analog Output Type

The Main Analog Output Type sets the output to specific voltages or currents. The available outputs are 0-20mA, 4-20mA, 0-10Vdc, -10 to +10Vdc, and 0-5Vdc. To change or view this value, press the **FUNC** key until **nonE** and **GROUP** show on the display. Press the **▲** key until **5** shows in the upper display. Press the **FUNC** key until the lower display changes to **MO.TYP**, and the upper display shows the selected type. Press the **▼** or **▲** keys until the upper display changes to the desired value. Then press the **FUNC** key to lock in the value and advance to the next parameter, or press **RESET** to return to the operating screen. Similarly if the unit has a Secondary input, the Secondary Analog Output Type (**SO.TYP**) can be set in the same manner.

8.6.2 Setting the Main Analog Output Link

To change or view this value, press the **FUNC** key until **nonE** and **GROUP** show on the display. Press the **▲** key until **3** shows in the upper display. Press the **FUNC** key until the lower display changes to **MO.LNK**, and the upper display shows the selected type, either **PrL.In** (the primary input) or **Sec.In** (the secondary Input). Press the **▼** or **▲** keys until the upper display changes to the desired value. Then press the **FUNC** key to lock in the value and advance to the next parameter, or press **RESET** to return to the operating screen. Similarly the Secondary Analog Output Link (**SO.LNK**) can be set in the same manner.

8.6.3 Setting the Main Analog Output Range Low

To change or view the Main Analog Output Range Low, press the **FUNC** key until **nonE** and **GROUP** show on the display. Press the **▲** key until **3** shows in the upper display. Press the **FUNC** key until the lower display changes to **MO.LO**. Press the **▼** or **▲** keys until the upper display changes to the desired value. The value may be anything from 0 to the primary input full scale value, **PI.FSV** if the **MO.LNK** is set to **PrL.Ln**, or if the **MO.LNK** is set to **Sec.Ln**, the value may be from -1000 to 3000. Once the desired value is set, press the **FUNC** key to lock in the value and advance to the next parameter, or press **RESET** to return to the operating screen. Similarly the Secondary Analog Output Range Low (**SO.LO**) can be set in the same manner.

8.6.4 Setting the Main Analog Output Range High

To change or view the Main Analog Output Range High, press the **FUNC** key until **nonE** and **GROUP** show on the display. Press the **▲** key until **3** shows in the upper display. Press the **FUNC** key until the lower display changes to **MO.HI**. Press the **▼** or **▲** keys until the upper display changes to the desired value. The value may be anything from 0 to the primary input full scale value, **PI.FSV** if the **MO.LNK** is set to **PrL.Ln**, or if the **MO.LNK** is set to **Sec.Ln**, the value may be from -1000 to 3000. Once the desired value is set, press the **FUNC** key to lock in the value and advance to the next parameter, or press **RESET** to return to the operating screen. Similarly the Secondary Analog Output Range High (**SO.HI**) can be set in the same manner.

8.6.5 Setting the Main Analog Output Filter

Filtering is an electrical method of averaging the output values over a period of time to arrive at a smoother curve. This helps to eliminate short duration transients and spikes that may cause false or spurious readings.

To change or view the Main Analog Output Filter, press the **FUNC** key until **nonE** and **GROUP** show on the display. Press the **▲** key until **2** shows in the upper display. Press the **FUNC** key until the lower display changes to **MO.FL**. Using the **▼** or **▲** keys, select the amount of filtering desired, from none (**OFF**) to five seconds. When finished, press the **FUNC** key to lock in the value and advance to the next parameter. Similarly the Secondary Analog Output Filter (**SO.FL**) can be set in the same manner.

8.7 Setting the Security Codes

There are three Security levels. When each level has been assigned a code access to the parameters will be available as follows:

- Level A: Allows access to parameters in Group 1 Only
- Level B: Allows access to parameters in Groups 1 and 2 Only
- Level C: Allows access to parameters to all Groups 1 - 5

8.7.1 Setting the Security Codes for Level A

To view or change the security code, press and hold the **FUNC** key for approximately 4 seconds. The Lower display changes to GOTO and the upper display reads OPr. If no buttons are pressed, the indicator reverts back to reading pressure. Press the **▲** key until the upper display reads "CodE". Press the **FUNC** key and the lower display changes to **CODE.A**. The upper display shows **0**, which indicates no security, and 1 means all parameters related to levels A, B, and C are always locked). Press the **▼** or **▲** keys until the desired security code number (from 2 to 250) appears in the upper display. Press the **FUNC** key to lock in the value. The upper display changes to **1**, and the lower display changes to **CODE.B**. This means that ONLY Levels B and C are locked, NOT Level A.

8.7.2 Setting the Security Codes for Level B

If you first set **CODE.A**, the lower display will read **CODE.B**; if not, press the **FUNC** key to move to **CODE.B**. The upper display shows **0**, which indicates no security; or it may show **1**, which means all parameters related to levels A, B, and C are always locked). Press the **▼** or **▲** keys until the desired security code number (from 251 to 500) appears in the upper display. Press the **FUNC** key to lock in the value. The lower display changes to **CODE.C**, and the Upper display shows **1**. This means that all levels are locked and cannot be changed.

8.7.3 Setting the Security Codes for Level C

If you first set **CODE.A** and **CODE.B**, the lower display will read **CODE.C**. If not, press the **FUNC** key to move to **CODE.C**. The upper display shows **0**, which indicates no security; a 1 means all parameters related to levels A, B, and C are always locked). Press the **▼** or **▲** keys until the desired security code number (from 501 to 1000)

appears in the upper display. Press the **FUNC** key to lock in the value. The upper display changes to **Code** and the lower display changes to **UPR**.

Once the security codes are selected, they CANNOT be displayed. If the codes are forgotten, new values must be entered using the above procedure. It is recommended that a code be set for each security level. Note that unlocking the Level C code unlocks Levels A, B, and C. To, relock a code, simply enter any incorrect number and all the locked levels will relock. Unlocking the Level B code, unlocks Levels A and B. Unlocking Level A unlocks only Level A. When the **SECUR** functions are accessed in Group 1, the levels that are locked will be followed by a decimal point.

8.7 Configure Differential Pressure

The UPR800 has capability to indicate differential pressure. The primary and secondary inputs can be either Strain Gage, 0-5Vdc, 0-10Vdc, 0-20mA or 4-20mA. Primary and secondary input types need not be matched types. By default the UPR800-1-X-X with secondary input option is shipped with setup to display temperature on the lower display. To execute the differential display function Group 5 parameter SI.TYP needs to be set from Temp (TC or RTD) to any Strain gage or V/mA setting and SI.FNC needs to be set to diFF.P (Differential Pressure). Wire either a mV/V strain gauge transducer, Volt, or Milliamp transmitter to terminals as show in Figures below.

Strain Gauge Transducer Figure 1.1
For Primary Input (PT1)

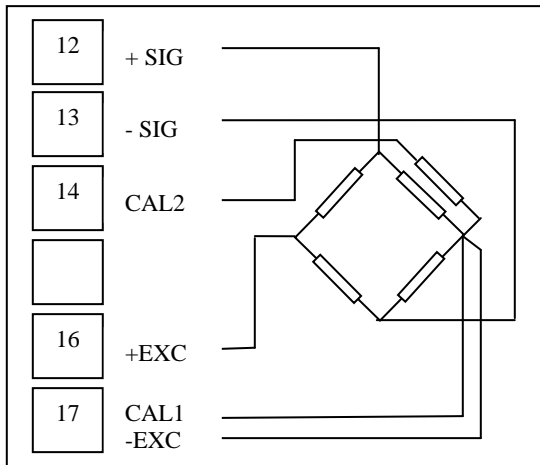

For Secondary Input (PT2)

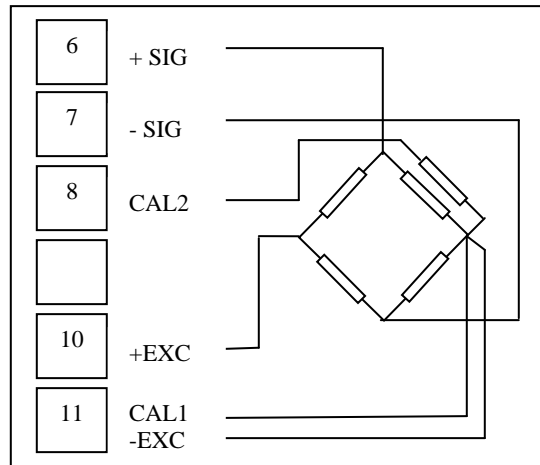

Note: If no internal Rcal is used, Cal1 and Cal2 may be omitted. For transducers with External cal resistors, please refer to the manufacturers recommended wiring instructions.

4-20mA Transmitter Wiring Diagram

For Primary Input (PT1)

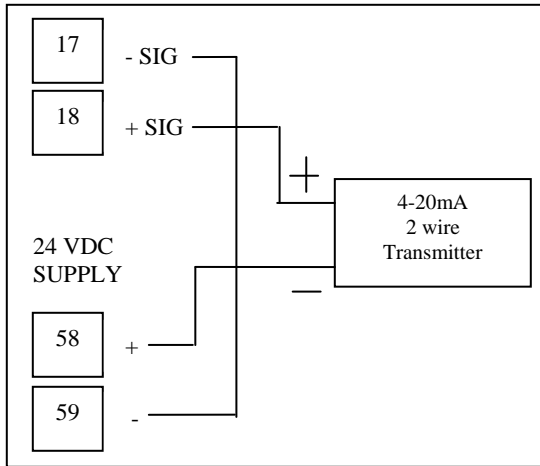

For Secondary Input (PT2)

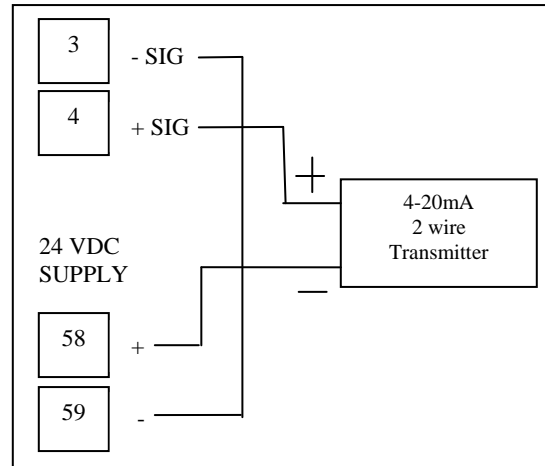

0-20mA Transmitter Wiring Diagram

For Primary Input (PT1)

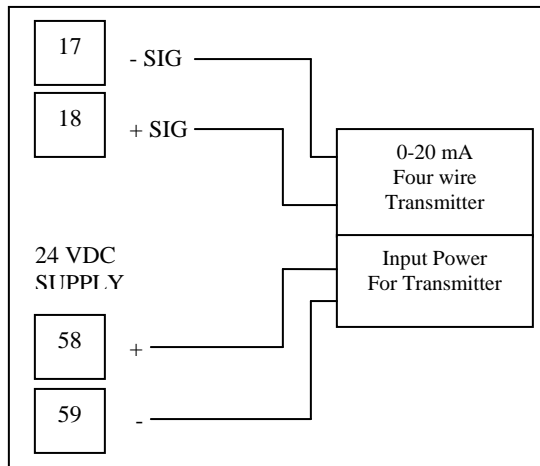

For Secondary Input (PT2)

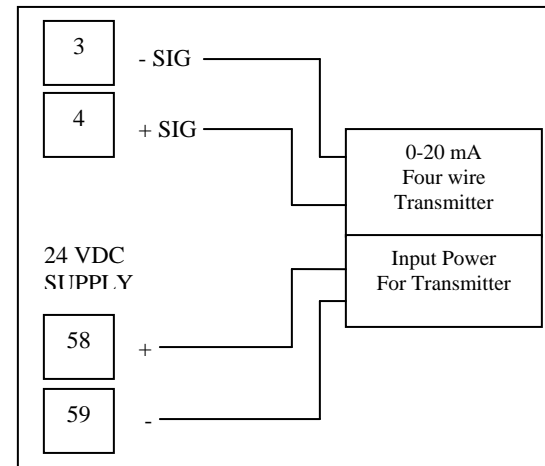

0-5 or 0-10Vdc Transmitter Wiring Diagram

For Primary Input (PT1)

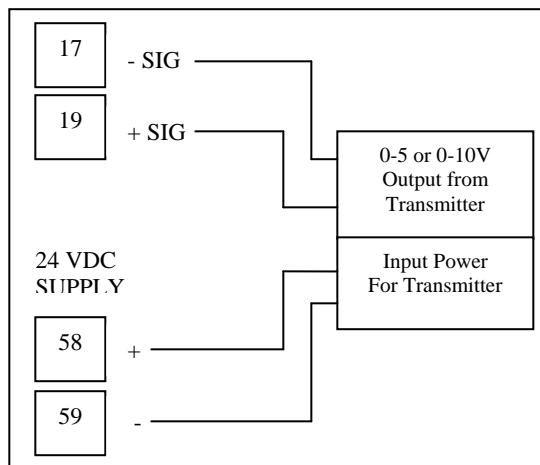

For Secondary Input (PT2)

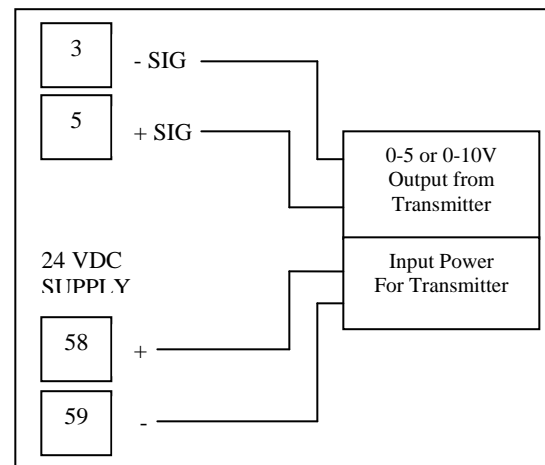

Configuration

Parameters are arranged in Groups 5 through 1 and are in order of frequent use. A general rule of thumb Group 5 parameters are modified once during setup of the indicator and gradually increase in frequency of use to Group 1 which includes Alarm thresholds that may be changed on a regular basis.

Parameters that are used only during differential operation are:

Group 1 PI.VAL – Used to display process value on Primary (Main) input

Group 1 SI.VAL – Used to display process value on Secondary input

Group 2 ZER.2.C – Used to zero calibrate secondary analog input

Group 2 SPN.2.C – Used to Span calibrate the secondary analog input

Group 3 SI.FSV – Used to scale secondary input full scale value







Group 3 SI.LSV – Used to scale secondary input lower scale value

Group 4 SI.IFS – Used to set secondary input Failsafe value

Group 5 SI.TYP (Str) – When set to Strain gage, controller sets SI.FNC to diff P

Group 5 SI.FNC – Used to toggle between Temperature or Differential mode

Group 5 – Input Output types

1. Proceed to Group 5 parameters by pressing the **FUNC** button until Group is shown on lower display and None is shown on upper display. Press the  arrow until Group 5 is displayed.
2. Press **FUNC** button once to display PI.TYP
3. Press  or  arrow until the desired Primary Input type is selected. Str for Strain gage, 0-20 for 0-20 mA, 4-20 for 4-20 mA, 0-5 for 0-5VDC, 0-10 for 0-10 VDC.
4. Press **FUNC** button to save and move on to the next parameter.
5. SI.TYP should now be displayed. Press  or  arrow until the desired Secondary Input type is selected. Str for Strain gage, 0-20 for 0-20 mA, 4-20 for 4-20 mA, 0-5 for 0-5VDC, 0-10 for 0-10 VDC. Note: Setting to either OFF, tc or RTD will turn off differential mode.
6. Press **FUNC** button to save and move to the next parameter. SI.FNC will now be displayed. If Strain gage was selected for SI.TYP, then the SI.FNC will automatically be set to diFF.P for Differential Pressure otherwise press the  arrow to select diFF.P
7. Press the **FUNC** button to save and move to the next parameter. MO.TYP will be displayed on the lower display. Press the  arrow to select the appropriate Main Analog Output Type. Analog outputs available are 0-10 for 0-10VDC, -10.10 for -10V to +10VDC, 0-5 for 0-5VDC, 0-20 for 0-20 mA, 4-20 for 4-20 mA. This selection should match the remote device analog input type used to remotely display the Delta Pressure.
8. Press **FUNC** to save and move to the next parameter. SO.TYP will be displayed (if option is fitted) on the lower display. Press the UP arrow to select the appropriate Secondary Retransmission Output Type. Retransmission outputs available are 0-10 for 0-10Vdc, -10.10 for -10V to +10Vdc, 0-5 for 0-5VDC, 0-20 for 0-20mA, 4-20 for 4-20mA or OFF if the Retransmission output is not used. This selection should match the remote device analog input type used to remotely display the Delta Pressure.

9. Press the **FUNC** button to save and move to the next parameter.
10. DEFLT will be displayed. This is only used to default the Group 5 parameters back to Factory Defaults. This is performed by pressing the **▲** arrow until ON 5 is displayed and then press the **FUNC** button to default otherwise press **FUNC** again to return to the GROUP display.

Group 4 – Shunt and Failsafe Settings

1. Pressure **FUNC** until Group is shown on lower display. Press the **▲** arrow to select Group 4.
2. Press **FUNC** again to move to SHUNT parameter. Depending on type of sensor connected to the primary and secondary inputs Shunt Calibration may or may not be used. Generally Shunt Cal is used on Strain gage transducers with millivolt output because calibration is performed at the Process indicator. Shunt should be set to OFF when using Transmitters with milliamp or volt outputs because the calibration is generally performed on the transmitter itself using zero and Span adjustments.
Note: Setting the SHUNT to off, the indicator will assume the span calibration will be the full scale of the sensor connected to the input.
3. Press **FUNC** to save and move to the next parameter. SHNT.% will be displayed on the lower display (If previous operation set SHUNT to ON). Using the **▲** or **▼** arrows, the % can be adjusted from 40.0 to 100.0 % of full scale. Dynisco Melt Pressure Transducers utilize 80% Shunt Cal output. Consult the manufacturer's documentation for recommended Shunt Calibration setting if using the controller with other sensors.
4. Press **FUNC** to save and move to the next parameter. PI.IFS will be displayed. Primary Input Failsafe can be set to HI or LO depending on the desired action if there is a sensor break. If set to HI, the process input will go high and cause any actions to react as if the process variable has increased to maximum. This includes any alarms and control output. Setting PI.IFS to LO will cause the process input to go to minimum if there is a sensor break.
5. Press **FUNC** to save and move to the next parameter. SI.IFS will be displayed. This setting is for the Secondary Input Failsafe and reacts the same as the Primary Input if there is a sensor break on the secondary input. Press **FUNC** to save the SI.IFS setting.
6. The remaining parameters in Group 4 relating to Alarm action, Logic Input function are outlined in section 8.

Group 3 – Display scaling and indication

1. Proceed to Group 3 parameters by pressing the **FUNC** button until Group is shown on lower display and None is shown on upper display. Press the **▲** arrow until Group 3 is displayed.
2. Press the **FUNC** button until PI.FSV is displayed. Using the **▲** and **▼** arrows, set the Primary Input full scale value to match the full range of the sensor connect to the Main input.
3. Press **FUNC** to save and move to the next parameter. PI.LSV will be displayed. Using the **▲** and **▼** arrows, set the Primary Input Low scale value to the minimum value, typically zero for Melt Pressure sensors.

4. Press **FUNC** to save and move to the next parameter. PI.DP will be displayed. USE the **▲** arrow to step through the decimal point position for the Primary input display.
5. Press **FUNC** to save and move to the next parameter. PI.EU will be displayed. Use the **▲** or **▼** arrows to step through the Primary Input Engineering Units. Available settings are PSI, Bar, Mpa, Kg/cm² or OFF if no Engineering unit is desired.
6. Press **FUNC** to save and move to the next parameter. SI.FSV will be displayed. Using the **▲** and **▼** arrows, set the Secondary Input full scale value to match the full range of the sensor connect to the Secondary input.
7. Press **FUNC** to save and move to the next parameter. SI.LSV will be displayed. Using the **▲** and **▼** arrows, set the Secondary Input Low scale value to the minimum value, typically zero for Melt Pressure sensors.
8. Press **FUNC** to save the SI.LSV parameter setting.
9. The remaining parameters in Group 3 relating to Alarm linking, Output and Setpoint scaling and communications addressing is outlined in Section 8.

Group 2 – Calibration of Sensors

1. Proceed to Group 2 parameters by pressing the **FUNC** button until Group is shown on lower display and None is shown on upper display. Press the **▲** arrow until Group 2 is displayed.
2. Press the **FUNC** button until ZERO.C is displayed on the lower display. Be sure zero pressure is applied to the primary input and press the **▲** arrow to turn upper display to ON. Press **FUNC** button to initiate Zero Calibration on the Primary Input. Note: CLEAR can be used to clear a zero calibration back to Factory setting of 0(mV/v/mA)
3. ZER.2.C should now be displayed on the lower display. Be sure zero pressure is applied to the secondary input and press the **▲** arrow to turn upper display to ON. Press **FUNC** button to initiate Zero Calibration on the Secondary Input.
4. SPAN.C should now be displayed on the lower display. If a Strain Gage transducer is used and Group 4 SHUNT is set to on, be sure zero is applied to the primary input and press the **▲** arrow to turn upper display to ON. The controller will use the simulated 80% (or other cal point set in Group 4 Span %) as the full scale pressure and span the Primary Input.
Note: CLEAR can be used to clear a Span calibrations back to Factory setting of 33.3mV, or 10V, 20mA depending on which input type is selected.
5. SPN.2.C should now be displayed on the lower display. If a Strain Gage transducer is used and Group 4 SHUNT is set to on, be sure zero is applied to the secondary input and press the **▲** arrow to turn upper display to ON. The controller will use the simulated rcal of 80% (or other cal point set in Group 4 Span %) as the full scale pressure and span the Secondary Input.
6. If using a 0-5/0-10V or 0-20/4-20 transmitter, it is recommended to rely on either the factory span or perform the span calibration on the transmitter itself using a deadweight pressure calibrator or other calibrated source.
7. Press **FUNC** button until Process Variable is displayed or press the **RESET** button to exit Group 2.

The remaining parameters in Group 2 relating to Alarm and Retransmission Filters is outlined in Section 8.

Group 1 – Displaying Individual PT1 and PT2 values

1. Press the **FUNC** button until PI.VAL is displayed in the lower display, this is the upstream or PT1 Primary Input pressure value.
2. Press the **FUNC** button once and SI.VAL is displayed in the lower display, this is the downstream or PT2 Secondary Input pressure value.
3. If no buttons are pressed within 10 seconds, the display times out and returns to display PT1-PT2 Delta pressure.

8.8 Configure by Remote PC (Configuration Port Interface or CPI)

The instrument provides an optional method to communicate with a PC host system to access each single operative and configuration parameter or to upload/download the complete instrument parameter set.

The optional system consists of:

- Dedicated adapter that interfaces the instrument to a RS-232 line.
- External wall power supply, to avoid powering the instrument through the main line.
- Receptacle for the five pins clip, located on the side of the instrument package; a mechanical polarization prevents incorrect insertion.
- PC configuration software.

When the Configuration Port Interface (CPI) is connected, all instrument functions are disabled. While connected, the device is in 'remote' mode for all parameter configuration, no matter the local security code settings.

The CPI connection is performed using a Modbus RTU protocol with fixed communication parameters (device address 255, data format 8 bit without parity and 9600 baud). The wall power supply for the CPI adapter has three different interchangeable plugs to accommodate US/Japanese, European and UK sockets. The CPI can also be used also for field upgrades of the instrument firmware. A USB/RS232 converter is compatible with the CPI.

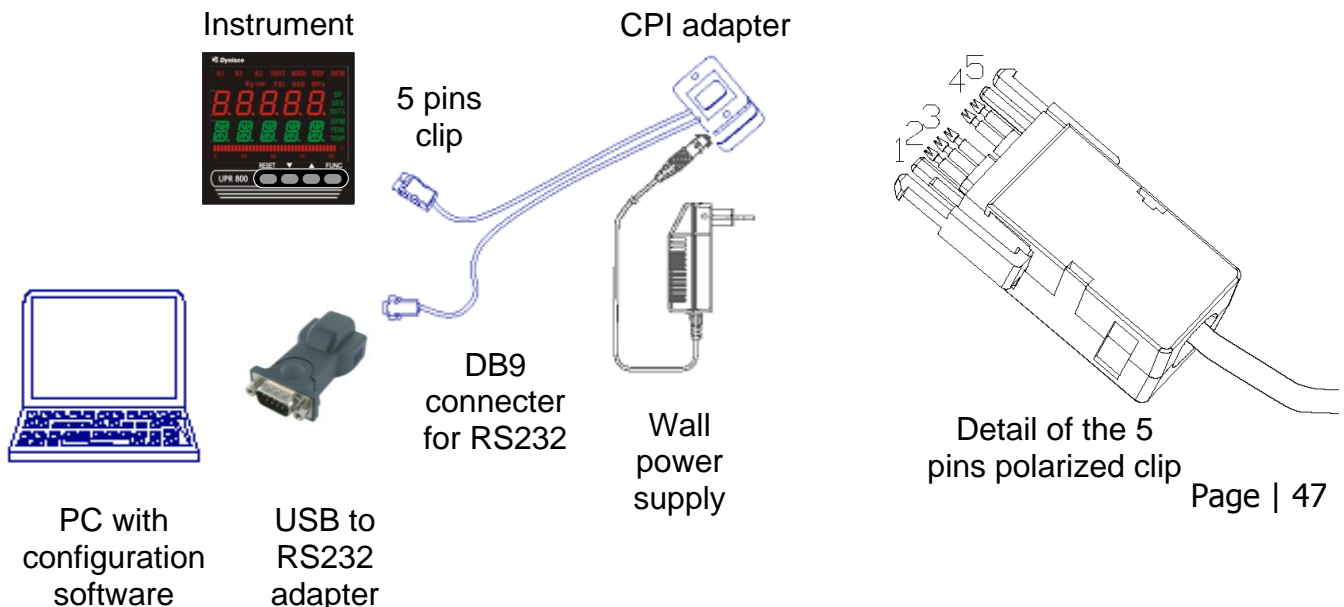

9.0 OPERATION

9.1 Primary Input Calibration

NOTE: In this section the word *Calibration* means to match the Instrument to the input device, so that a specific signal from the input device is equated to a specific pressure and no other, (to the capabilities of its input resolution)

Apply power to the cabinet and allow the system to stabilize for about 30 minutes. Allow the transducer or other input device to come up to operating conditions.

9.1.1 Calibration of Pressure Transducers Equipped with an Internal Shunt Resistor

Be sure that the full scale and low scale values (*PI.FSV* and *PI.LSV*) have been set to match the range of the transducer and that the **SHUNT** function is **ON** and set to the correct percentage (80% for a typical Dynisco transducer).

To calibrate the transducer to the instrument, press the **FUNC** key until **nonE** and **GROUP** show on the display. Press the **▲** key until **2** shows in the upper display. Press the **FUNC** key and the lower display changes to **ZERO.C**. The upper display shows **OFF**. Press the **▼** or **▲** keys until the upper display changes to **ON**. Press the **FUNC** key to calibrate the zero value. The lower display changes to **SPAN.C**. The upper display shows **OFF**. Press the **▼** or **▲** keys until the upper display changes to **ON**.

Press the **FUNC** key to calibrate the span value. When the legend **DSP.FL** appears in the lower display, calibration is complete. Press **RESET** to return to the operating screen.

9.1.2 Calibration of Amplified Pressure Transmitters with an Internal Shunt Resistor

Be sure that the full scale and low scale values (*PI.FSV* and *PI.LSV*) have been set to match the range of the transducer and that the **SHUNT** function is turned **OFF**.

To calibrate the transducer to the instrument, press the **FUNC** key until **nonE** and **GROUP** show on the display. Press the **▲** key until **2** shows in the upper display. Press the **FUNC** key and the lower display changes to **ZERO.C**. The upper display shows **OFF**. Press the **▼** or **▲** keys until the upper display changes to **ON**. Press the **FUNC** key to calibrate the zero value. The lower display changes to **SPAN.C**. The upper display shows **OFF**. Press the **▼** or **▲** keys until the upper display changes to **CLEAR**. Press the **FUNC** key to calibrate the span value. When the legend **DSP.FL** appears in the lower display, calibration is complete. Press **RESET** to return to the operating screen.

9.1.3 Calibration of Pressure Transducers with External Shunt Resistors

Install the external shunt resistor across terminals 13 (signal -) and 14 (Cal 2). Be sure that the full scale and low scale values (*PI.FSV* and *PI.LSV*) have been set to match the range of the transducer and that the **SHUNT** function is **ON** and set to the correct percentage (as supplied by the transducer manufacturer. If the values supplied is an actual pressure value, convert to a percentage and enter in **SHNT.%**).

To calibrate the transducer to the instrument, press the **FUNC** key until **nonE** and **GROUP** show on the display. Press the **▲** key until **2** shows in the upper display. Press the **FUNC** key and the lower display changes to **ZERO.C**. The upper display shows **OFF**. Press the **▼** or **▲** keys until the upper display changes to **ON**. Press the **FUNC** key to calibrate the zero value. The lower display changes to **SPAN.C**. The upper display shows **OFF**. Press the **▼** or **▲** keys until the upper display changes to **ON**. Press the **FUNC** key to calibrate the span value. When the legend **DSP.FL** appears in the lower display, calibration is complete. Press **RESET** to return to the operating screen.

9.1.4 Calibration of Analog Inputs Using a Pressure Calibration Source

Be sure that full scale and low scale values have been set to the range of the process sensor. Press the **FUNC** key until **nonE** and **GROUP** show on the display. Press the **▲** key until **4** shows in the upper display. Press the **FUNC** key and the upper display should show **OFF** while the lower display shows **SHUNT**. If the upper display does not show **OFF**, press the **▼** or **▲** key until the upper display changes to **OFF**. Press the **FUNC** key to set the value and press **RESET** to return to the operating screen.

Press the **FUNC** key until **nonE** and **GROUP** show on the display. Press the **▲** key until **2** shows in the upper display. Press the **FUNC** key and the lower display changes to **ZERO.C**. The upper display shows **OFF**. With low scale equivalent signal applied from an appropriate calibration source, press the **▼** or **▲** keys until the upper display changes to **ON**. Press the **FUNC** key to calibrate the zero value. When the lower display changes to **SPAN.C**, zero calibration is complete. With signal applied equivalent to full scale value from an appropriate calibration source, press the **▼** or **▲** keys until the upper display changes to **ON**. Press the **FUNC** key to calibrate the span value. When the legend **DSP.FL** appears in the lower display, calibration is complete. Press **RESET** to return to the operating screen.

These inputs are factory pre-calibrated for the following ranges, and require no further calibration.

- Voltage: 0-5 VDC, 0-10 VDC
- Current: 4-20 mA; 0-20 mA.

9.1.5 Calibration of the UPR800 to Calibrated Linear Analog Input

Be sure that full scale and low scale values have been set to the range of the process sensor. Press the **FUNC** key until **nonE** and **GROUP** show on the display. Press the **▲** key until **4** shows in the upper display. Press the **FUNC** key and the upper display should show **OFF** while the lower display shows **SHUNT**. If the upper display does not show **OFF**, press the **▼** or **▲** key until the upper display changes to **OFF**. Press the **FUNC** key to set the value and press **RESET** to return to the operating screen.

Press the **FUNC** key until **nonE** and **GROUP** show on the display. Press the **▲** key until **2** shows in the upper display. Press the **FUNC** key and the lower display changes to **ZERO.C**. The upper display shows **OFF**. With the input at the low scale value, press the **▼** or **▲** keys until the upper display changes to **ON**. Press the **FUNC** key to calibrate the

zero value. When the lower display changes to **SPAN.C**, zero calibration is complete. Press the **▼** or **▲** keys until the upper display changes to **CLEAR**. Press the **FUNC** key to restore the linear factory calibration of the span value. When the legend **DSP.FL** appears in the lower display, calibration is complete. Press **RESET** to return to the operating screen.

9.2 Instrument Calibration

NOTE: In this section the word *Calibration* means to set the Instrument to an internationally recognized standard, independent of input device.

9.2.2 General Calibration Procedure

- 1.) Use the **▼** or **▲** keys to show the following functions:
 - Firmware revision
 - Pressure input counts
 - Zero, for the strain gage input (P.ST.ZE)
 - Span, for the strain gage input (P.ST.SP)
 - Pressure (P.STR)
 - Zero, for the linear inputs (P.LN.ZE)
 - Span, for the linear inputs (P.LN.SP)
 - Current (P.020)
 - Voltage, 0-10V (P.010)
 - Secondary input counts
 - Zero, for the strain gage input (S.ST.ZE)
 - Span, for the strain gage input (S.ST.SP)
 - Pressure (S.STR)
 - Zero, for the linear inputs (S.LN.ZE)
 - Span, for the linear inputs (S.LN.SP)
 - Current (S.020)
 - Voltage, 0-10V (S.010)
 - Thermocouple and RTD (S.TC.PT)
 - Reference junction (S.RJ)
 - Line resistance for RTD (S.RL)
 - Line frequency (FREQ)
 - Digital inputs status (DIG.IN)
 - Maximum Power Consumption
 - Minimum Power Consumption
- 2.) The display values for analog inputs are scaled from 0 to 25,000 counts; it is also linear for RTD input.
- 3.) Use the **▼** or **▲** keys to select a display value from 0 to 10 and to check the linearity of output circuit at 0%, 10%, 90% and 100%.
- 4.) If the values do not correspond with the values in the Calibration Parameters Summary Table below, use the **▼** or **▲** keys to correct the value displayed.
- 5.) When all the appropriate values are correct, depress the **FUNC** key.

- 6.) If the values CANNOT be made to correspond with the values in the Calibration Parameters Summary Table, the instrument must be sent to Dynisco for repair or re-calibration.

See the following Calibration Parameter Summary.

CALIBRATION PARAMETERS SUMMARY					
PARAMETER	CIRCUIT	INPUT TYPE	RANGE	VALUE	NOTE
PL.020	Primary Input	Current	Zero	0mA	
PH.020	Primary Input	Current	Full scale	20mA	
P.020	Primary Input	Current	Verify		(2)
PL.05	Primary Input	Voltage 0-5V	Zero	0V	
PH.05	Primary Input	Voltage 0-5V	Full scale	5V	
P.05	Primary Input	Voltage 0-5V	Verify		(2)
PL.010	Primary Input	Voltage 0-10V	Zero	0V	
PH.010	Primary Input	Voltage 0-10V	Full scale	10V	
P.010	Primary Input	Voltage 0-10V	Verify		(2)
SL.020	Secondary Input	Current	Zero	0mA	
SH.020	Secondary Input	Current	Full scale	20mA	
S.020	Secondary Input	Current	Verify		(2)
SL.05	Secondary Input	Voltage	Zero		
SH.05	Secondary Input	Voltage	Full scale		
S.05	Secondary Input	Voltage	Verify		(2)
SL.010	Secondary Input	Voltage	Zero	0V	
SH.010	Secondary Input	Voltage	Full scale	10V	
S.010	Secondary Input	Voltage	Verify		(2)
SL.TC	Secondary Input	Thermocouple	Zero	0mV	
SH.TC	Secondary Input	Thermocouple	Full scale	50mV	
S.TC	Secondary Input	Thermocouple	Verify		(2)
S*RJ	Secondary Input	Thermocouple	Ref. junct.	Ambient	
S.RJ	Secondary Input	Thermocouple	Verify	Ambient	
SL.RTD	Secondary Input	RTD100	Zero	0Ω	(2)
SH.RTD	Secondary Input	RTD100	Full scale	320Ω	
S.RTD	Secondary Input	RTD100	Verify		(2)
SL.PT5	Secondary Input	RTD500	Zero	0Ω	
SH.PT5	Secondary Input	RTD500	Full scale	1600Ω	
S.PT5	Secondary Input	RTD500	Verify		(2)
ML.CUR	Main analog output	Current	Zero	-5 mA	
MH.CUR	Main analog output	Current	Full Scale	25 mA	
M.CUR	Main analog output	Current	Verify		(3)
ML.VOL	Main analog output	Voltage	Zero	-12.5V	
MH.VOL	Main analog output	Voltage	Full scale	12.5V	
M.VOL	Main analog output	Voltage	Verify		(3)
SL.CUR	Second analog output	Current	Zero	-5 mA	
SH.CUR	Second analog output	Current	Full scale	25 mA	
S.CUR	Second analog output	Current	Verify		(3)
SL.VOL	Second analog output	Voltage	Zero	-12.5V	
SH.VOL	Second analog output	Voltage	Full scale	12.5V	
S.VOL	Second analog output	Voltage	Verify		(3)
DEFLT	Load default calibration and code	DO NOT ATTEMPT TO MODIFY UNDER ANY CIRCUMSTANCES			

Notes for Calibration Parameter Summary:

- (1) Use the **▼** or **▲** keys to show the following functions:
 - Firmware revision
 - Pressure input counts
 - Zero, for the strain gage input (P.ST.ZE)
 - Span, for the strain gage input (P.ST.SP)
 - Pressure (P.STR)
 - Zero, for the linear inputs (P.LN.ZE)
 - Span, for the linear inputs (P.LN.SP)
 - Current (P.020)
 - Voltage, 0-10V (P.010)
 - Secondary input counts
 - Zero, for the strain gage input (S.ST.ZE)
 - Span, for the strain gage input (S.ST.SP)
 - Pressure (S.STR)
 - Zero, for the linear inputs (S.LN.ZE)
 - Span, for the linear inputs (S.LN.SP)
 - Current (S.020)
 - Voltage, 0-10V (S.010)
 - Thermocouple and RTD (S.TC.PT)
 - Reference junction (S.RJ)
 - Line resistance for RTD (S.RL)
 - Line frequency (FREQ)
 - Digital inputs status (DIG.IN)
 - Maximum power consumption
 - Minimum power consumption
- (2) The display values for analog inputs are scaled from 0 to 25000 counts; the read-out is linear also for the RTD inputs.
- (3) Use the **▼** or **▲** keys to select a display value from 0 to 10 and to check the linearity of output circuit at 0%, 10%, .. 90% and 100% of full scale value +/- 0.05% of full scale value.

9.3 RS-485 (Optional)

The UPR800 is available with an RS-485 Digital communications port. The configuration parameters for this option are found in the Group 3 parameters only if this option is included. The UPR800, when equipped with this option, is compatible with Modbus and Jbus protocols, the choice of which is made in the Configuration/Setup menu. The Modbus/Jbus Communications manual is available on request.

9.3.1 Serial Communication Interface Address

This function is used to set the serial Communication Interface Address. To view or access this function, press the **FUNC** key until **nonE** and **GROUP** show on the display. Press the **▲** key until **3** shows in the upper display. Press the **FUNC** key and the lower display changes to **SC.ADR**. The upper display shows **OFF**. Press the **▼** or **▲** keys until the upper display changes to the appropriate address, from 1 to 255. Press the **FUNC** key to store the value, and to view the next parameter. If finished, press **RESET** to return to the operating screen.

9.3.2 Protocol Type

This function is used to select the Protocol Type. To view or access this function, press the **FUNC** key until **nonE** and **GROUP** show on the display. Press the **▲** key until **3** shows in the upper display. Press the **FUNC** key and the lower display changes to **SC.BUS**. The upper display shows **nodbS**. Press the **▼** or **▲** keys until the upper display changes to the appropriate protocol, either Modbus (**nodbS**) or Jbus (**JbuS**). Press the **FUNC** key to store the value, and to view the next parameter. If finished, press **RESET** to return to the operating screen.

9.3.3 Communication Type

This function is used to select the number and format of the serial bits used in communication. To view or access this function, press the **FUNC** key until **nonE** and **GROUP** show on the display. Press the **▲** key until **3** shows in the upper display. Press the **FUNC** key and the lower display changes to **SC.FRM**. The upper display shows **8**. Press the **▼** or **▲** keys until the upper display changes to the appropriate bit format, 8 bit without parity (**8**), 8 bit with even parity (**8 E**), or 8 bit with odd parity (**8 O**). Press the **FUNC** key to store the value, and to view the next parameter. If finished, press **RESET** to return to the operating screen.

9.3.4 Communication Baud Rate

This function is used to select the Communication Baud Rate. To view or access this function, press the **FUNC** key until **nonE** and **GROUP** show on the display. Press the **▲** key until **3** shows in the upper display. Press the **FUNC** key and the lower display changes to **SC.BDR**. The upper display shows **19200**. Press the **▼** or **▲** keys until the upper display changes to the appropriate Baud rate: 600, 1200, 2400, 4800, 9600, or 19200.

Press the **FUNC** key to store the value, and to view the next parameter. If finished, press **RESET** to return to the operating screen.

Further documentation is available in Dynisco's publication #974089 *Modbus/J-Bus Protocol for Dynisco UPR800/ATC880*. Please visit www.dynisco.com or contact Dynisco at 800-221-2201 for an electronic copy of this manual.

10.0 ERROR CODES

On power up, the UPR800 will enter a self-test mode to evaluate the condition of the equipment. If an error is detected, the screen will show an error code number in the upper display and the mnemonic **Err**, in the lower display.



10.1 Error Codes and Troubleshooting

The errors codes and their possible causes and solutions are as follows:

- 1** Error during EEPROM access.
Correction: De-power the instrument and wait for 60 seconds. On power-on the situation should clear itself. If it does not correct itself de-power again. If the error still remains, send the instrument to Dynisco for repair (See Section 11.)
- 3** Wrong zero measure.
Correction: Check that the wiring is correct. Check that there is NO pressure applied on the transducer. If there is no pressure on the transducer, and the wiring is correct, contact Dynisco Technical Assistance at 800-221-2201.
- 5** Input calibration error.
Correction: Check that there is no pressure applied to the transducer. If the transducer is at zero pressure, verify that the SHUNT is turned on, and software configuration is correctly. Also verify that the wiring is correct, especially that the Orange wire is on Terminal 14, and the Blue wire is on Terminal 17 with the Green wire. Disconnect the transducer from the wiring, and either replace the wire, or check the continuity of EACH wire, and that there is no short between any of the wires. If the cable is good, substitute a known good transducer to determine if the transducer is damaged. If the good transducer shows the same error, send the instrument to Dynisco for repair (See Section 11.)
- 6** Wrong Reference Junction Measure.
Correction: The on-board thermocouple cold reference junction was read improperly. Press RESET to try to clear. If this does not work, turn the instrument off, wait about a minute, and turn the power back on. Verify that the instrument is not outside its operating temperature (-20 to 60°C). If the error persists, send the instrument to Dynisco for repair (See Section 11.)
- 11** Overload or short-circuit on primary strain gage input, or unconnected "+EXC" or "-EXC" wire.
Correction: An instrument set for primary strain gage input with NO transducer connected will display this error. Connect a transducer to the instrument to remedy this condition. If there is a transducer connected, disconnect it from the wiring, and either replace the wire, or check the continuity of EACH wire, and that there is no short between any of the wires. If the cable is good, substitute a known good transducer to determine if the transducer is damaged. If the good transducer shows the same error, send the instrument to Dynisco for repair.
- 13** Incorrect span value
- 14** Internal I2C bus communication error with eeproms
- 15** Internal I2C bus communication error with I/O expanders
- RAM** Failure of RAM circuit. There is no correction; the device needs to be sent to Dynisco for repair.

If differential pressure input is used, the error message in the "Normal Display Mode" will indicate the type failure. Review the Group 1 list and look at the "PI.VAL" or "SI.VAL" parameters to identify the faulty channel.

When the upper display shows "Err" and the lower display shows a parameter mnemonic code this means that the related parameter is in error status. In this situation three options are available:

- 1) If the wrong parameter is a run-time parameter (i.e. from AL1 to SO.TYP for UPR880), press the  or  keys and the instrument will load the default values for all groups of parameters.
- 2) If the wrong parameter is a calibration or code parameter press the "FUNC" + "RES" keys to enable the instrument to access the run-time parameters; this function is intended only to restore a misplaced parameter's value. The user is advised to check the stated calibration or code parameter.
- 3) If the wrong parameter is a calibration or code parameter pressing the "FUNC" push-button for one second the instrument enters the operating mode switching procedure. This allows the user to select the calibration or code operating mode to recalibrate or to fix the wrong parameter.

10.2 "OPEN" Error Code and Troubleshooting

- The display will show "OPEN" under one or more of the following conditions:
- A/D converter saturation (indicating a signal outside the expected range)
- Input current lower than 0.8 mA (for 4-20mA inputs)
- Primary input lower than -25% or higher than 125% of full scale value.
- "SIG +" or "SIG -" wire unconnected for strain gage input
- Remote set point input lower than -1% or higher than 101% of full scale value
- Linear secondary input lower than -1% or higher than 101% of full scale value
- One or more unconnected thermocouple or TD input
- Excess line resistance for thermocouple or RTD input
- Thermocouple or RTD input value outside the specified range.
- Connection cable wire broken or two wires shorted together
- The Orange (CAL2) and Blue (CAL1) wires are on the wrong terminals for a strain gage transducer. The Orange (CAL2) wire connects to terminal 17 (EXC-) together with the Green wire. The Blue (CAL1) wire connects to terminal 14. If the transducer is wired to DHF or (WRSG) Western Regional Strain Gage standards, contact Dynisco Technical Service at 800-221-2201

10.3 Instrument Maintenance

1. REMOVE POWER FROM THE POWER SUPPLY TERMINALS AND FROM RELAY OUTPUT TERMINALS BEFORE REMOVING THE INSTRUMENT FROM CASE
2. Remove instrument from case. To accomplish this, twist off the lateral screw located on the right side of the front panel and spread the two locking tabs located on either side of the case with a tool such as coins or keys used to aid the mechanical function . The instrument will move forward past the locked position.

Grasp the bezel and slide the instrument from the case. Depending on the options chosen, you may find that one or two boards appear to be loosely mounted. This patent-pending design allows the instrument to be removed from the case without having to overcome the friction of all terminals on all boards at one time. Initially the CPU board and alarm board will be released, followed by the I/O and digital communication boards.

3. Using a vacuum cleaner or a compressed air jet (max. 42 PSI) remove all deposits of dust and dirt which may be present on the louvers and on the internal circuits trying to be careful not to damage the electronic components.
4. To clean external plastic or rubber parts use only a cloth moistened with:
 - Ethyl Alcohol—pure or denatured (C₂H₅OH) or
 - Isopropyl Alcohol—pure or denatured ((CH₃)₂CHOH) or
 - Water (H₂O)
 - Always use the mildest means available.
5. Verify that there are no loose terminals
6. Before re-inserting the instrument in its case, be sure that it is perfectly dry
7. Carefully slide the instrument back into its case, until the locking tabs have engaged. An audible click will be heard as each tab engages. Screw in the screw located on the right side of the front panel.

11.0 NORMATIVE REFERENCES

UL 94:	Tests for flammability of plastic materials for parts in devices and appliances.
EN 60529:	Degrees of protection provided by enclosures (IP Code).
Nema 250-1991:	Enclosures for electrical equipment (1000 Volts maximum).
DIN 43700:	Measurements and control instruments for panel mounting; Nominal front and cut-out dimensions.
EN 61010-1	Safety requirements for electrical equipment for measurements, control and laboratory use Part 1: General requirements
EN 61326-1	Electrical equipment for measurement, control and laboratory use - EMC requirements.
EN 55011	Industrial, scientific and medical (ISM) radio-frequency equipment Radio disturbance characteristics. Limit and method of measurement.
EN 61000-4-2	Electromagnetic compatibility (EMC) Part 4: Testing and measurement techniques Section 2: Electrostatic discharge immunity test
EN 61000-4-3	Electromagnetic compatibility - Basic immunity standard - Radiated radio-frequency electromagnetic field - Immunity test
EN 61000-4-4	Electromagnetic compatibility (EMC) Part 4: Testing and measurement techniques Section 4: Electrical fast transient/burst immunity test
EN 61000-4-5	Electromagnetic compatibility (EMC) Part 4: Testing and measurement techniques Section 5: Surge immunity test
EN 61000-4-6	Electromagnetic compatibility-Basic immunity standard- Conducted disturbances induced by radio-frequency fields Immunity test
EN 61000-4-11	Electromagnetic compatibility (EMC) Part 4: Testing and measurement techniques

Section 11: Voltage dips, short interruptions and voltage variations immunity test

IEC 751:1995: Thermometers - References table

DIN 43710-1977: Thermocouples - References table

IEC 584-1:1995: Thermocouples - References table

12.0 PARAMETER GROUP MENUS

Group 1	Function	As Set
AL.MSK	Alarms Mask Reset	
SECUR	Security	
AL1	Alarm 1 Threshold	
AL2	Alarm 2 Threshold	
AL3	Alarm 3 Threshold	
PI.VAL	Primary Pressure Input Value	
SI.VAL	Secondary Pressure Input Value	
DEFLT	Loading Default Data	
GROUP	Group Access Number	
Group 2	Function	As Set
ZERO.C	Zero Calibration	
ZER.2.C	Zero Calibration For Secondary Input	
SPAN.C	Span Calibration	
SPN.2.C	Span Calibration of Secondary Input	
DSP.FL	Display Filter	
A1.FL	Alarm 1 Filter	
A2.FL	Alarm 2 Filter	
A3.FL	Alarm 3 Filter	
MO.FL	Main Analog Output Filter	
SO.FL	Second Analog Output Filter	
DEFLT	Loading Default Data	
Group 3	Function	As Set
PI.FSV	Primary Input Full Scale Value	
PI.LSV	Primary Input Low Scale Value	
PI.DP	Primary Input Decimal Point Position	
PI.EU	Primary Input Engineering Unit	
SI.TC	Secondary Input Thermocouple Type	
SI.RTD	Secondary Temperature Input RTD Type	
SI.C/F	Engineering Unit For Secondary Input	
SI.LO	Secondary Input Range Low	
SI.HI	Secondary Input Range High	
SI.DP	Secondary Input Decimal Point System	
SI.FSV	Secondary Input Full Scale Value	
SI.LSV	Secondary Input Low Scale Value	
A1.LNK	Alarm 1 Input Channel Link	
A1.TYP	Alarm 1 Type	
A2.LNK	Alarm 2 Input Channel Link	
A2.TYP	Alarm 2 Type	
A3.LNK	Alarm 3 Input Channel Link	
A3.TYP	Alarm 3 Type	
MO.LNK	Main Analog Output Link	
MO.LO	Main Output Range Low	



DYNISCO UPR800 Series Instruction Manual

MO.HI	Main Output Range High	
SO.LNK	Second Analog Range Link	
SO.LO	Second Output Range Low	
SO.HI	Second Output Range High	
SC.ADR	Serial Communication Interface Address	
SC.BUS	Protocol Type	
SC.FRM	Communication Type	
SC.BDR	Communication Baud Rate	
DEFLT	Loading Default Data	
Group 4	Function	As Set
SHUNT	Shunt Calibration	
SHNT.%	Shunt Value	
PI.IFS	Primary Input Fail Safe	
SI.IFS	Secondary Input Fail Safe	
A1.HYS	Alarm 1 Hysteresis	
A1.RES	Alarm 1 Reset Mode	
A1.FSM	Alarm 1 Failsafe Mode	
A2.HYS	Alarm 2 Hysteresis	
A2.RES	Alarm 2 Reset Mode	
A2.FSM	Alarm 2 Failsafe Mode	
A3.HYS	Alarm 3 Hysteresis	
A3.RES	Alarm 3 Reset Mode	
A3.FSM	Alarm 3 Failsafe Mode	
LI.TYP	Logic Input Configuration	
LI.STS	Logic Input Status	
PEAK	Peak Detection	
PI.DUT	Pressure Input Display Update Time	
SI.ST	Secondary Temperature Input Sample Time	
LINE.F	Line Frequency	
LINE.R	Line Frequency Readout	
DEFLT	Loading Default Data	
Group 5	Function	As Set
PI.TYP	Primary Input Selection	
SI.TYP	Secondary Input Selection	
SI.FNC	Secondary Input Function	
MO.TYP	Main Analog Output Selection	
SO.TYP	Second Analog Output Selection	
DEFLT	Loading Default Data	
Group 6	Function	As Set
PB.LOC	Pointer Location Selector	
IN. 0	Pointer Value	
DEFLT	Loading Default Data	



For your convenience, use **As Set** column to enter your individual settings.

12.1 Group 1 Parameters

ALARMS MASK RESET - Group 1

Available: Only if one or more alarms are configured with mask at start-up
Upper display: OFF
Lower display: AL.MSK
Range: Use the   keys to switch the upper display from OFF to rESEt, then press the FUNC key to restore the alarm mask.
Default value: Not applicable

SECURITY - Group 1

Available: Only if CODE.A or CODE.B or CODE.C are On.
Upper display: A b C or A b C. or A b. C or A. b. C. One or more letters followed by a decimal point means that the access to modification of the parameters of the related security level is inhibited.
Lower display: SECUR
Range: Use   keys to input the security code; if the selected code matches the programmed code the parameters of the related security level are unlocked. The unlock operation also unlocks the parameters of the lower numbered groups, while the lock operation locks all the parameters. To choose new security codes enter the “Security Code Setting” operating mode. In order to re-lock the different groups insert any number with the exception of the selected codes.

ALARM 1 THRESHOLD - Group 1

Available: Only if A1.LNK is different than OFF.
Upper display: Alarm 1 threshold value
Lower display: AL1
Range: From low to high scale of the related input. The high limit may be expanded to 110% of span.
Default value: 40% of range of the related input.

ALARM 2 THRESHOLD - Group 1

Available: Only if A2.LNK is different than OFF.
Upper display: Alarm 2 threshold value
Lower display: AL2
Range: From low to high scale of the related input. The high limit may be expanded to 110% of span.
Default value: 60% of range of the related input.

ALARM 3 THRESHOLD - Group 1

Available: Only if A3.LNK is different than OFF.
Upper display: Alarm 3 threshold value
Lower display: AL3
Range: From low to high scale of the related input. The high limit may be expanded to 110% of span.

Default value: 80% of range of the related input.



PRIMARY PRESSURE INPUT VALUE - Group 1

Available: Only if SI.TYP is different from 'OFF' and SI.FNC is equal to 'diff.P'.
Upper display: Primary pressure input value
Lower display: PI.VAL
Range: Read-only parameter.
Default value: Not applicable.



SECONDARY PRESSURE INPUT VALUE - Group 1

Available: Only if SI.TYP is different from 'OFF' and SI.FNC is equal to 'diff.P'.
Upper display: Secondary pressure input value
Lower display: SI.VAL
Range: Read-only parameter.
Default value: Not applicable.

LOADING DEFAULT DATA - Group 1

Available: Only if access to level A is allowed.
Upper display: OFF
Lower display: DEFLT
Range: Use   keys to switch the upper display from OFF to On 1, the press FUNC key to load the default data of the parameters belonging to Group 1.

GROUP ACCESS NUMBER

Available: Always
Upper display: OFF
Lower display: GROUP
Range: Use   keys to switch the upper display from nonE to 1, 2, 3, 4 or 5 and then gain access to the parameters of the selected group by pressing the FUNC key.



12.2 Group 2 Parameters

ZERO CALIBRATION - Group 2

Available: Always
Upper display: OFF
Lower display: ZERO.C
Range: to switch the upper display from OFF to On then press FUNC key to start the zero calibration. It is also possible to select "CLEAR" value to delete the field calibration and restore factory calibration.
Default value: Zero

ZERO CALIBRATION FOR SECONDARY INPUT - Group 2

Available: Only if SI.TYP is different from 'OFF' and SI.FNC is equal to 'diff.P'.
Upper display: OFF
Lower display: ZER.2.C

Range: Use   keys to switch the upper display from OFF to On then press FUNC key to start the zero calibration. It is also possible to select the 'CLEAR' value to delete the field calibration and then restore factory calibration.

Default value: Zero

SPAN CALIBRATION - Group 2

Available: Always

Upper display: OFF

Lower display: SPAN.C

Range: to switch the upper display from OFF to On then press FUNC key to start the span calibration. It is also possible to select "CLEAR" value to delete the field calibration and restore factory calibration.



Default value: Full scale for linear input, 33.3mV for strain gage input.

SPAN CALIBRATION FOR SECONDARY INPUT - Group 2

Available: Only if SI.TYP is different from 'OFF' and SI.FNC is equal to 'diff.P'.

Upper display: OFF

Lower display: SPN.2.C

Range: Use   keys to switch the upper display from OFF to On then press FUNC key to start the zero calibration. It is also possible to select the 'CLEAR' value to delete the field calibration and then restore factory calibration.

Default value: Full scale for linear input, 33.3mV for strain gage input

DISPLAY FILTER - Group 2

Available: Always

Upper display: Time constant of the display filter (primary input).

Lower display: DSP.FL

Range: OFF, 0.4, 1, 2, 3, 4, 5 sec.

Default value: 0.4 sec.

ALARM 1 FILTER - Group 2

Available: Only if A1.LNK is different than OFF.

Upper display: Time constant of the alarm 1 filter.

Lower display: A1.FL

Range: OFF, 0.4, 1, 2, 3, 4, 5 sec.

Default value: 0.4 sec.

ALARM 2 FILTER - Group 2

Available: Only if A2.LNK is different than OFF.

Upper display: Time constant of the alarm 2 filter.

Lower display: A2.FL

Range: OFF, 0.4, 1, 2, 3, 4, 5 sec.

Default value: 0.4 sec.

ALARM 3 FILTER - Group 2

Available: Only if A3.LNK is different than OFF.
Upper display: Time constant of the alarm 3 filter.
Lower display: A3.FL
Range: OFF, 0.4, 1, 2, 3, 4, 5 sec.
Default value: 0.4 sec.



MAIN ANALOG OUTPUT FILTER - Group 2

Available: Only if MO.TYP is different than OFF.
Upper display: Time constant of the main analog output filter.
Lower display: MO.FL
Range: OFF, 0.4, 1, 2, 3, 4, 5 sec.
Default value: 0.4 sec.

SECOND ANALOG OUTPUT FILTER - Group 2

Available: Only if SO.TYP is different than OFF.
Upper display: Time constant of the second analog output filter.
Lower display: SO.FL
Range: OFF, 0.4, 1, 2, 3, 4, 5 sec.
Default value: 0.4 sec.

LOADING DEFAULT DATA - Group 2

Available: Only if access to level B is allowed.
Upper display: OFF
Lower display: DEFLT
Range: Use   keys to switch the upper display from OFF to On 2, then press FUNC key to load the default data of the parameters belonging to Group 1 and Group 2.

12.3 Group 3 Parameters



PRIMARY INPUT FULL SCALE VALUE - Group 3

Available: Always
Upper display: Full scale value
Lower display: PI.FSV
Range: From 10 to 99950. Changes to this value causes loading of the default values for the pressure input low scale, the alarm set points, the retransmission limits and the secondary input low/high range, if the latter is configured for differential pressure measurement
Default value: 10000.

PRIMARY INPUT LOW SCALE VALUE - Group 3

Available: Always
Upper display: Low scale value
Lower display: PI.LSV
Range: from -/+25% of Full scale value
Default value: 0

PRIMARY INPUT DECIMAL POINT POSITION - Group 3

Available: Always
Upper display: Full scale value
Lower display: PI.DP
Range: Use   keys to select the position of the decimal point
Default value: None

PRESSURE INPUT ENGINEERING UNIT - Group 3

Available: Always.
Upper display: Engineering unit beacon to lit up.
Lower display: PI.EU
Range: OFF, PSI, bAr, hGcn2, nPa, where: OFF is all beacons are turned off; PSI is first beacon (PSI) lit; bAr is second beacon (Bar) lit; hGcn2 is third beacon (kg/cm²) lit; nPa fourth beacon (MPa) lit
Default value: PSI.

SECONDARY INPUT THERMOCOUPLE TYPE - Group 3

Available: Only if SI.TYP is tc
Upper display: Selected thermocouple type of temperature input.
Lower display: SI.TC
Range: tc J, tc CA, tc L, tc N, tc E, tc T. (thermocouple J, thermocouple K (Cromel lumel), thermocouple L, thermocouple N, thermocouple E, thermocouple T.)
Default value: Thermocouple J

TEMPERATURE (SECONDARY) INPUT RTD TYPE - Group 3

Available: Only if SI.TYP is RTD
Upper display: Selected RTD type of temperature input
Lower display: SI.RTD
Range: Pt100, Pt500
Default value: Pt100

ENGINEERING UNIT FOR SECONDARY INPUT - Group 3

Available: Only if SI.TYP is tc or RTD
Upper display: Selected type of temperature input engineering unit.
Lower display: SI.C/F
Range: Celsius or Fahrenheit
Default value: °F



SECONDARY INPUT RANGE LOW - Group 3

Available: Only if SI.TYP is 0-20, 4-20 or 0-10 and SI.FNC is equal to 'temp'
Upper display: Secondary input range low
Lower display: SI.LO
Range: from -1000 to 3000
Default value: 0

SECONDARY INPUT RANGE HIGH - Group 3

Available: Only if SI.TYP is 0-20, 4-20 or 0-10 and SI.FNC is equal to 'tenp'
Upper display: Secondary input range high
Lower display: SI.HI
Range: from -1000 to 3000
Default value: 1000

SECONDARY INPUT DECIMAL POINT POSITION - Group 3

Available: Only when SI.TYP is 0-20, 4-20 or 0-10 and SI.FNC is equal to 'tenp'
Upper display: Secondary input range high
Lower display: SI.DP
Range: Use   keys to select the position of the decimal point
Default value: None

SECONDARY INPUT FULL SCALE VALUE - Group 3

Available: Only if SI.TYP is different from 'OFF' and SI.FNC is equal to 'diff.P'.
Upper display: Secondary input full scale value.
Lower display: SI.FSV
Range: From 0 to the full scale value (4000, 8000, 20000, 40000, 80000 or 99950, according to the pressure input full scale value).
Default value: 10000.

SECONDARY INPUT LOW SCALE VALUE - Group 3

Available: Only if SI.TYP is different from 'OFF' and SI.FNC is equal to 'diff.P'.
Upper display: Secondary input low scale value.
Lower display: SI.LSV
Range: From +/- 25% of the 'Secondary input full scale value' parameter (SI.FSV).
Default value: 0.

ALARM 1 INPUT CHANNEL LINK - Group 3

Available: Always
Upper display: Configuration for alarm 1 selection
Lower display: A1.LNK
Range: OFF, PrI.In, Sec.In. Disabled, primary input, secondary input
Default value: Primary input

ALARM 1 TYPE - Group 3

Available: Only if A1.LNK is different than OFF
Upper display: Selection of alarm 1 type
Lower display: A1.TYP
Range: HI, LO, Inhlb. High, low, low with mask at start-up
Default Value: High

ALARM 2 INPUT CHANNEL LINK - Group 3

Available: Always
Upper display: Configuration for alarm 2 selection

Lower display: A2.LNK
Range: OFF, PrI.In, SEc.In. Disabled, primary input, secondary input
Default value: Primary input

ALARM 2 TYPE - Group 3

Available: Only if A2.LNK is different than OFF
Upper display: Selection of alarm 2 type
Lower display: A2.TYP
Range: HI, LO, Inhlb. High, low, low with mask start-up
Default value: High

ALARM 3 INPUT CHANNEL LINK - Group 3

Available: Only if Alarm 3 output is fitted.
Upper display: Configuration for alarm 3 selection
Lower display: A3.LNK
Range: OFF, PrI.In, SEc.In. Disabled, primary input, secondary input
Default value: Disabled

ALARM 3 TYPE - Group 3

Available: Only if A3.LNK is different than OFF.
Upper display: Selection of alarm 3 type.
Lower display: A3.TYP
Range: HI, LO, Inhlb. High, low, low with mask at start-up
Default value: High

MAIN ANALOG OUTPUT LINK - Group 3

Available: Only if SI.TYP is different than OFF and SI.FNC is equal to 'tenp'
Upper display: Selected type for man analog output
Lower display: MO.LNK
Range: PrI.In, SEc.In. Primary input, secondary input
Default value: Primary input

MAIN ANALOG OUTPUT RANGE LOW - Group 3

Available: Only if MO.TYP is different than OFF
Upper display: Range low for main analog output
Lower display: MO.LO
Range: from 0 to PI.FSV (if PO.LNK = PrI.In) from -1000 to 3000 (if PO.LNK = SEc.In)
Default value: 0

MAIN ANALOG OUTPUT RANGE HIGH - Group 3

Available: Only if MO.TYP is different than OFF
Upper display: Range high for main analog output.
Lower display: MO.HI
Range: from 0 to PI.FSV (if PO.LNK = PrI.In) from -1000 to 3000 (if PO.LNK = SEc.In)
Default value: PI.FSV

SECONDARY ANALOG OUTPUT LINK - Group 3

Available: Only if SO.TYP is different than OFF and SI.TYP is different than OFF
Upper display: Selected type for second analog output
Lower display: SO.LNK
Range: PrI.In, SEc.In. Primary input, secondary input
Default value: Primary input

SECONDARY ANALOG OUTPUT RANGE LOW - Group 3

Available: Only if SO.TYP is different than OFF and SI.FNC is equal to 'tenp'
Upper display: Range low for second analog output.
Lower display: SO.LO
Range: from 0 to PI.FSV (if SO.LNK = PrI.In) from -1000 to 3000 (if SO.LNK = SEc.In)
Default value: 0

SECOND ANALOG OUTPUT RANGE HIGH - Group 3

Available: Only if SO.TYP is different than OFF.
Upper display: Range high for second analog output.
Lower display: SO.HI
Range: from 0 to PI.FSV (if SO.LNK = PrI.In) from -1000 to 3000 (if SO.LNK = SEc.In).
Default value: PI.FSV.

SERIAL COMMUNICATION INTERFACE ADDRESS - Group 3

Available: Only if serial communication interface is fitted.
Upper display: Serial communication interface address
Lower display: SC.ADR
Range: OFF, 1, 2, Ö, 255. Off disables serial interface
Default value: Off

PROTOCOL TYPE - Group 3

Available: Only if SC.ADR is different than off
Upper display: Protocol type
Lower display: SC.BUS
Range: nodbS, JbuS. Modbus/Jbus selection
Default value: Modbus



COMMUNICATION TYPE - Group 3

Available: Only if SC.ADR is different than Off
Upper display: Number of bits
Lower display: SC.FRM
Range: 8, 8 E, 8 O. 8 bit without parity, 8 bit + even parity, 8 bit + odd parity
Default value: 8 bit without parity

COMMUNICATION BAUD RATE - Group 3

Available: Only if SC.ADR is different than Off
Upper display: Baud rate
Lower display: SC.BDR
Range: 600, 1200, 2400, 4800, 9600, 19200
Default value: 19200

LOADING DEFAULT DATA - Group 3

Available: Only if access to level 3 is allowed
Upper display: OFF
Lower display: DEFLT
Range: Use   keys to switch the upper display from OFF to On 3, then press FUNC key to load the default data of the parameters belonging to group 1, group 2, group 3

12.4 Group 4 Parameters

SHUNT CALIBRATION - Group 4

Available: Always
Upper display: OFF if shunt calibration is disabled, On if shunt calibration is enabled
Lower display: SHUNT
Range: OFF, On
Default value: On

SHUNT VALUE - Group 4

Available: Only if SHUNT parameter is on
Upper display: Shunt value
Lower display: SHNT.%
Range: From 40.0 to 100.0%
Default value: 80.0%

PRIMARY INPUT FAIL SAFE - Group 4

Available: Always
Upper display: Primary input fail safe condition
Lower display: PI.IFS
Range: HI, LO
Default value: High

SECONDARY INPUT FAIL SAFE - Group 4

Available: Only if SI.TYP is different than OFF
Upper display: Secondary input fail safe condition
Lower display: SI.IFS
Range: HI, LO
Default value: High

ALARM 1 HYSTERESIS - Group 4

Available: Only if A1.LNK is different than OFF
Upper display: Alarm 1 hysteresis

Lower display: A1.HYS
Range: From 0.1 to 10.0% of the selected range
Default value: 1.0%

ALARM 1 RESET MODE - Group 4

Available: Only if A1.LNK is different than OFF
Upper display: Selected reset mode for alarm 1
Lower display: A1.RES
Range: Auto, LAtCh. Automatic reset, manual reset
Default value: Auto

ALARM 1 FAILSAFE MODE - Group 4

Available: Only if A1.LNK is different than OFF
Upper display: Selected failsafe mode for alarm 1
Lower display: A1.FSM
Range: FS, nFS. Failsafe mode, non-failsafe mode
Default value: Failsafe mode

ALARM 2 HYSTERESIS - Group 4

Available: Only if A2.LNK is different than OFF
Upper display: Alarm 2 hysteresis
Lower display: A2.HYS
Range: From 0.1 to 10.0% of the selected range
Default value: 1.0%

ALARM 2 RESET MODE - Group 4

Available: Only if A2.LNK is different than OFF
Upper display: Selected reset mode for alarm 2
Lower display: A2.RES
Range: Auto, LAtCh. Automatic reset, manual reset
Default value: Auto

ALARM 2 FAILSAFE MODE - Group 4

Available: Only if A2.LNK is different than OFF
Upper display: Selected failsafe mode for alarm 1
Lower display: A2.FSM
Range: FS, nFS. Failsafe mode, non-failsafe mode
Default value: Failsafe mode

ALARM 3 HYSTERESIS - Group 4

Available: Only if A3.LNK is different than OFF
Upper display: Alarm 3 hysteresis
Lower display: A3.HYS
Range: From 0.1 to 10.0% of the selected range
Default value: 1.0%

ALARM 3 RESET MODE - Group 4

Available: Only if A3.LNK is different than OFF
Upper display: Selected reset mode for alarm 3
Lower display: A3.RES
Range: Auto, LAtCh. Automatic reset, manual reset
Default value: Auto

ALARM 3 FAILSAFE MODE - Group 4

Available: Only if A3.LNK is different than OFF
Upper display: Selected failsafe mode for alarm 1
Lower display: A3.FSM
Range: FS, nFS. Failsafe mode, non-failsafe mode
Default value: Failsafe mode

LOGIC INPUT CONFIGURATION - Group 4

Available: Always
Upper display: Configuration of logic input
Lower display: LI.TYP
Range: OFF, AL, P, AL-P. Disabled, alarm reset, peak reset, alarm and peak reset
Default value: Alarm and peak reset

LOGIC INPUT STATUS - Group 4

Available: Only if LI.TYP is different than OFF.
Upper display: Status of logic input.
Lower display: LI.STS
Range: CLOSE, OPEn. The logic input is considered active when the contact is closed or open with respect to this parameter.
Default value: Closed.

PEAK DETECTION - Group 4

Available: Always.
Upper display: Polarity of peak detector
Lower display: PEAK
Range: OFF, HI, LO. Disabled, maximum peak, minimum peak
Default value: Maximum peak

PRESSURE INPUT DISPLAY UPDATE TIME - Group 4

Available: Always.
Upper display: Display update time for the pressure input.
Lower display: PI.DUT
Range: 0.050, 0.100, 0.250, 0.400 sec.
Default value: 0.400 sec.

SECONDARY INPUT SAMPLE TIME - Group 4

Available: Only if SI.FNC is equal to 'tenp'.
Upper display: Sample time for the secondary input.
Lower display: SI.ST

Range: 0.100, 0.200, 0.500, 1.000 sec.
Default value: 0.500 sec.



LINE FREQUENCY - Group 4

Available: Always.
Upper display: Line frequency rejection.
Lower display: LINE.F
Range: 50, 60, Auto
50 Hz, 60 Hz, automatic detection of the line frequency (except 24Vdc power supply).
Default value: Auto.

LINE FREQUENCY READOUT - Group 4

Available: Only when the LINE.F parameter is set to Auto.
Upper display: Read-only value of the detected line frequency.
Lower display: LINE.R
Range: 50, 60, und.60
50, 60: when the device is able to detect correctly 50 or 60 Hz line frequency. und.60: automatic detection of the line frequency doesn't work (e.g. 24V DC power supply); a 60 Hz rejection is assumed.
Default value: Not applicable.

LOADING DEFAULT DATA - Group 4

Available: Only if access to level C is allowed
Upper display: OFF
Lower display: DEFLT
Range: Use   keys to switch the upper display from OFF to On 4, then press FUNC key to load the default data of the parameters belonging to group 1, group 2, group 3 and group 4

12.5 Group 5 Parameters

PRIMARY INPUT SELECTION - Group 5

Available: Always
Upper display: Type of primary input selection
Lower display: PI.TYP
Range: Str, 0-20, 4-20, 0-5, 0-10. Strain gage, 0-20mA, 4-20mA, 0-5V, 0-10V
Default value: Strain gage
Note: Proper terminal block wiring required

SECONDARY INPUT SELECTION - Group 5

Available: Only is secondary input circuit is fitted
Upper display: Type of secondary input selection
Lower display: SI.TYP
Range: OFF, tc, rtd, 0-20, 4-20, 0-10. Disabled thermocouple, RTD, 0-20 mA, 4-20mA, 0-10V
Default value: Thermocouple

Note: Proper terminal block wiring required

SECONDARY INPUT FUNCTION - Group 5

Available: Only if SI.TYP is different from OFF.
Alterable: Only if SI.TYP is equal to 0-20, 4-20, 0-5, 0-10; otherwise it is forced according to the SI.TYP value.
Upper display: Function of secondary input.
Lower display: SI.FNC
Range: temp, diff.P., where temp input acts as a temperature input and diff.P input acts as the second sensor for differential pressure measurement
Default value: temp.



MAIN ANALOG OUTPUT SELECTION - Group 5

Available: Always
Upper display: Type of main analog output selection
Lower display: MO.TYP
Range: 0-20, 4-20, 0-10, -10.10, 0-5. 0-2mA, 4-2 mA, 0-10V, 0-5V.
Default value: 0-10V.
Note: Proper terminal block wiring required

SECOND ANALOG OUTPUT SELECTION - Group 5



Available: Only if second output is fitted
Upper display: Type of second analog output selection
Lower display: SO.TYP
Range: OFF, 0-20, 4-20, 0-10, -10.10, 0-5. Disabled, 0-20mA, 4-20 mA, 0-10V, -10-10V, 0-5V.
Default value: 0-10V
Note: Proper terminal block wiring required

LOADING DEFAULT DATA - Group 5

Available: Only if access to level C is allowed
Upper display: OFF
Lower display: DEFLT
Range: Use   keys to switch the upper display from OFF to On 5, then press FUNC key to load the default data of the parameters belonging to group 1, group 2, group 3, group 4 and group 5

12.6 Group 6 Parameters

SECURITY CODE - LEVEL A

Available: Always
Upper display: 0, 1, On
Lower display: CODE.A
Range: Use   keys to input the security codes. 0 means no security code (all parameters related to level A are always unlocked). 1 means no security code (all parameters related to level A, level B and



level C are always locked). A number from 2 to 250 is the code for level A protection

SECURITY CODE - LEVEL B

Available: Only if CODE.A is 0 or On

Upper display: 0, 1, On

Lower display: CODE.B



Range: Use   keys to input the security codes. 0 means no security code (the parameters related to level A and level B are always unlocked). 1 means no security code (all parameters related to level B and level C are always locked). A number from 251 to 500 is the code for level B protection

SECURITY CODE - LEVEL C

Available: Only if CODE.B is 0 or On

Upper display: 0, 1, On

Lower display: CODE.C

Range: Use   keys to input security codes. 0 means no security code (the parameters related to level A, level B and level C are always unlocked)

1 means no security code (all parameters related to level C are always locked). A number from 501 to 1000 is the code for level C protection.

NOTE: Once security codes are selected, their values cannot be displayed again but the display shows On. If the codes are forgotten, new values should be chosen, using the above procedure. It is recommended that a code be set for each security level. Note that unlocking the Level C code unlocks Levels A, B and C. Unlocking Level B unlocks Levels B and A. Unlocking Level A only Unlocks Level A. When the SECUR functions are accessed in Group 1, the levels that are locked will be followed by a decimal point. E.g. A.b.C. indicates that all the levels are locked.

13.0 WARRANTY AND SERVICE:

This equipment is subject to the mutual agreement that it is warranted to be free from defects of material and construction but our liability in connection with it shall be limited to repairing or replacing without charge at our factory any material or construction defects which become apparent within one year from the date on which the equipment is shipped, that we have no liability for damages of any kind arising from the installation or use of this apparatus by anyone and that the purchaser by the acceptance of this equipment will assume all liability for any damages which may result from its use or misuse by the purchaser, his or its employees or by others. There is no guarantee or warranty or liability except as here stated.

Should the equipment require service or repair, please call for a Return Material Authorization Number, and return it, along with a brief description of any problem(s) encountered, freight prepaid to:

Dynisco Instruments

38 Forge Parkway

Franklin, MA 02038

Attn: Repair Dept. **RMA#** (call for RMA#)

Please call for a Return Material Authorization Number before returning product to Dynisco.

NOTE: Before returning any product for repair, please call the Dynisco Customer Service Department at 800-332-2245 or 508-541-9400 (or E-mail: repair@mc.dynisco.com) for a Return Authorization Number. Questions concerning warranty, repair cost, or delivery should be directed to the Dynisco Service Department as well.

For further technical assistance, call 800-221-2201