

Dynisco®

Dynisco Instruments

38 Forge Parkway,
Franklin MA 02038

Replaced by the
ATC 880

Stocked, Distributed, and Supported by

SENSORS
INCORPORATED

507 Kelsey Street • Delano, MN 55328
Phone 763-972-1040 Fax 763-972-1041
Toll Free 888-920-0939
Sensorsincorporated.com

DYNISCO μ PC660

MICROPROCESSOR BASED

PRESSURE CONTROLLER

OPERATION MANUAL

TOPIC	SECTION
INTRODUCTION	1-0
SPECIFICATIONS	1-1
INSTALLATION	2-0
MOUNTING	2-1
AC POWER WIRING	2-2
INPUT WIRING	2-3
PRIMARY OUTPUT WIRING	2-4
ALARM WIRING	2-5
AUXILIARY OUTPUT WIRING	2-6
OPTIONAL REMOTE CONTACT WIRING	2-7
OPERATING INSTRUCTIONS	3-0
FRONT PANEL DESCRIPTION	3-1
OPERATING MODES	3-2
CONFIGURATION MODE	3-3
CONTROL MODE	3-4
TRANSDUCER CALIBRATION	3-5
CONTROL PARAMETERS	3-6
CONTROLLER TUNING	3-7
KEYBOARD LOCKOUT	4-0
ERROR MESSAGES	4-1
OUTPUT CALIBRATIONS	4-2
LOADING DEFAULT PARAMETERS	4-3
SERIAL COMMUNICATION INTERFACE	5-0
LOCAL/REMOTE SWITCH	5-1
SERIAL COMMUNICATION WIRING	5-2
PROTOCOL (see separate manual)	5-3
CONTROLLER DEFINITIONS	6-0
ALARM CONFIGURATION EXAMPLES	7-0
WARRANTY AND SERVICE	8-0

MANUAL P/N 974057

8/93

1-0 INTRODUCTION

The μ PC660 is a microprocessor based controller designed for single loop pressure control. Input from a standard Dynisco 350 ohm strain gage pressure transducer can be easily ranged and calibrated through the front keyboard. The control action is full PID with a user choice of 0-20/4-20 mA or 0-10 VDC 12 bit (0.03% F.S.V.) resolution output. A dual slope A/D conversion of less than 100 mS enables the μ PC660 to respond to today's rapid processes. Dual 4 digit alphanumeric displays aid in user setup and operation. Also standard are fully programmable dual alarms, bumpless auto/manual transfer, seven segment LED displays and 0-5 VDC auxiliary output. Optional features include a third alarm and serial communications interface via RS232C, RS422, or RS485.

Please review this manual carefully prior to installation and operation.

1-1 SPECIFICATIONS

GENERAL

Case: ABS black

Displays: Upper display four 12.7mm high 7 segment LED's from -1999 to +9999. Lower display four 7.6mm high seven segment LED's from -1999 to +9999. Decimal point settable at any position from the front keyboard.

Dimensions: DIN 43700 96 x 96 mm, 160 mm deep.

Panel cutout: 92 x 92 mm \pm 0.5 mm

Power Supply: 120/240VAC 50/60 HZ \pm 10 %

Insulation resistance: > 100 MOhm

Analog / Digital Conversion: dual slope 100 milli second conversion. Display update every four conversions.

Accuracy: \pm 0.2% FSV \pm 1 digit @ 25°C ambient (77°F)

Resolution: 1 digit

Input temperature drift: < 150 PPM / °C

Ambient temperature: 0-50°C (32-122°F)

Humidity: 85% RH non-condensing

INPUTS

Type: standard Dynisco 6 wire 350 ohm strain gage pressure transducer.

Sensitivity: auto range from 2 to 4 mV/V

Zero balance: \pm 25% full scale

Bridge excitation: 10VDC nominal

Span Calibration Range: programmable from 40% to 100% (default is 80% for Dynisco).

Input protection: if any transducer lead is disconnected, displays show open circuit and output is forced to zero.

CONTROL ACTIONS

Control mode: PID

Proportional band: adjustable from 1 to 200%, resolution 1 digit.

Integral: adjustable from 0.1 to 99.9 seconds, resolution 0.1 seconds. Adjusting integral over 99.9 seconds excludes integral action.

Derivative: adjustable from 0.1 to 99.9 seconds. Adjusting derivative to 0 seconds excludes derivative action.

CONTROL OUTPUT

Type: (Optoisolated) 0-10 VDC or 4-20 mA output selectable by keyboard and internal jumper

Resolution: 0.1% in manual mode; 0.03% in automatic mode (12 bit).

Load impedance: 500 ohm maximum for mA output, 500 ohm minimum for 0-10 VDC output

Action: direct/reverse, keyboard selectable

Modes: manual or auto PID, bumpless transfer from manual to auto

ALARMS

Number: two standard, three optional

Alarm mode: selectable process, deviation, or band alarm

Alarm output: two alarms; dual SPDT relays, three alarms; 3 SPST relays

Contact rating: 4A @ 250 VAC resistive load

Hysteresis: $\pm 0.39\%$ FSV

ANALOG RECORDER OUTPUT

Type: Linear, 0-5 VDC non-isolated

Max Load Current: 2 mA

Resolution: 0.03% (12 bit)

Max. Range: -25% to +125% of span

EXTERNAL CONTACTS (Optional)

Inputs: 3 CPU isolated contacts

Description: 1 contact for each of the following: auto/manual selection, increasing power output, decreasing power output (manual mode)

Contact Rating: 10 mA minimum

Selection: activated from front keyboard

2-0 INSTALLATION

2-1 MOUNTING

Prepare a panel cutout per the dimensions detailed below. Remove the four mounting brackets from either side of the instrument. Insert the unit into the panel cutout from the front of the panel. While holding the unit firmly against the panel re-install the mounting brackets by sliding them forward until the unit is held firmly against the panel. Panels with a maximum thickness of 5mm can be used.

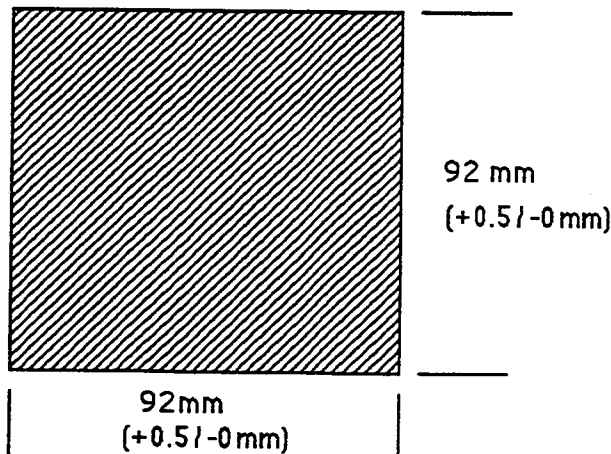

2-2 AC POWER WIRING

AC power is wired as detailed in the following diagram. Note that all rear terminal connections are made with "Fast Ons" Amphenol P/N 640905-1 for 14 thru 16 AWG or equal.

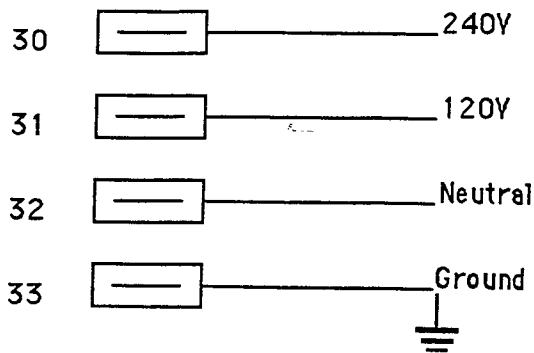

Terminal 33 must be connected to earth ground.

Terminal number 5 must be connected to terminal 33.

2-3 INPUT WIRING

Connect the pressure transducer per the instructions detailed below. Do not run input wires in the same conduit with power cables. Shielded cable should be used and grounded at the transducer end only (Dynisco's cable assembly provides this grounding).

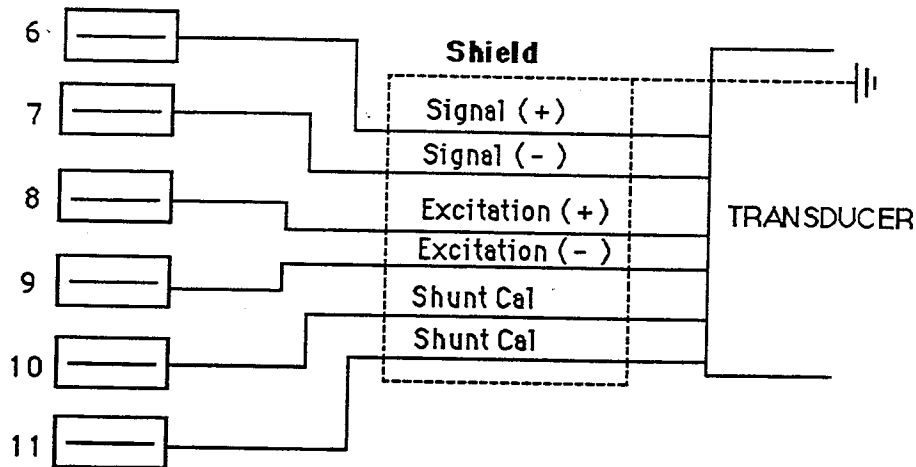

DYNISCO STANDARD WIRE CODE

LEAD	COLOR
EXCITATION+	WHITE
SIGNAL +	RED
EXCITATION-	GREEN
SIGNAL-	BLACK
CALIBRATION	BLUE
CALIBRATION	ORANGE

TRANSDUCER PIN-OUT

PT420 SERIES	PT460 SERIES
A	C
B	A
C	D
D	B
E	E
F	F
G (unused)	
H (unused)	

2-4 PRIMARY OUTPUT WIRING

μ PC660's output is isolated from main circuit ground. Wiring is achieved as detailed below.

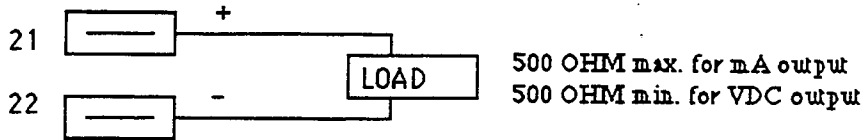

2-5 ALARMS WIRING

μ PC660 is available with either two alarms (standard) or three alarms (optional). The two alarm version has SPDT contacts while the three alarm version has SPST contacts. In both cases alarm contact rating is 4A @ 250VAC resistive load. Alarm wiring is detailed below. See section 3-3 for alarm programming.

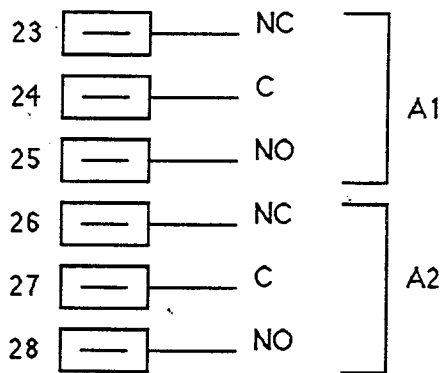

TWO ALARM
VERSION

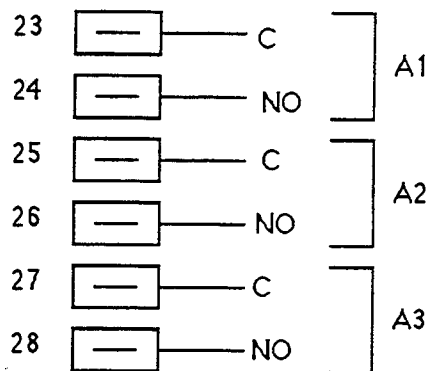

THREE ALARM
VERSION

2-6 AUXILIARY OUTPUT WIRING

μ PC660 has a 0-5VDC auxiliary output which can be found at terminals 2(+) and 3(-).

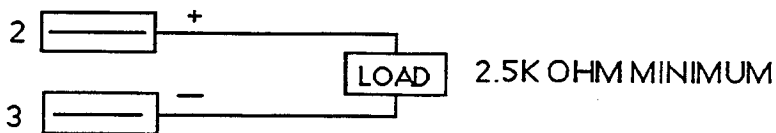

2-7 OPTIONAL REMOTE CONTACT WIRING

The μ PC660 controller is offered with an ECI option that allows the functions of the Auto/Manual and Up/Down keys to be remotely operated via the controller's rear terminals.

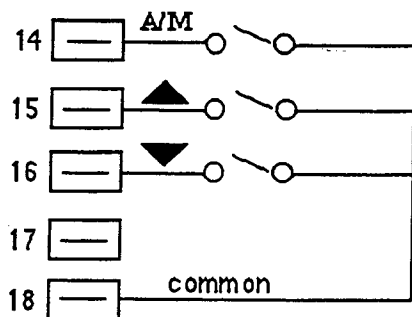

The terminals have the following function:

A/M

open = automatic operation
closed = manual operation



open = no change
closed = increase control power output



open = no change
closed = decrease control power output

The A/M contact must be closed (Manual Mode) in order for the up or down contacts to be active. The external contacts are isolated from the main circuit ground but not between the contacts. If these contacts are closed at the same time, no output change will occur.

NOTE: This option can be added to a standard controller. Specify Dynisco's part number 820723.

REAR TERMINALS

□	1	□	12	23	□
□	2	□	13	24	□
□	3	□	14	25	□
□	4	□	15	26	□
□	5	□	16	27	□
□	6	□	17	28	□
□	7	□	18	29	□
□	8	□	19	30	□
□	9	□	20	31	□
□	10	□	21	32	□
□	11	□	22	33	□

TERMINAL NUMBER

DESCRIPTION

1	UNUSED
2	0-5 VDC AUX OUTPUT (+)
3	0-5 VDC AUX OUTPUT (-)
4	UNUSED
5	GROUND
6	SIGNAL+
7	SIGNAL -
8	EXCITATION +
9	EXCITATION -
10	SHUNT CALIBRATION
11	SHUNT CALIBRATION
12-20	FOR SERIAL COMMUNICATION OR EXTERNAL CONTACT OPTION
21	CONTROL OUTPUT (+)
22	CONTROL OUTPUT (-)
23	ALARM 1 NC
24	ALARM 1 C
25	ALARM 1 NO
26	ALARM 2 NC
27	ALARM 2 C
28	ALARM 2 NO
29	UNUSED
30	240 VAC
31	120 VAC
32	NEUTRAL
33	EARTH GROUND

NOTE: AVOID USING UNUSED TERMINALS AS TIE POINTS

3-0 OPERATING INSTRUCTIONS

3-1 FRONT PANEL FEATURE DESCRIPTION

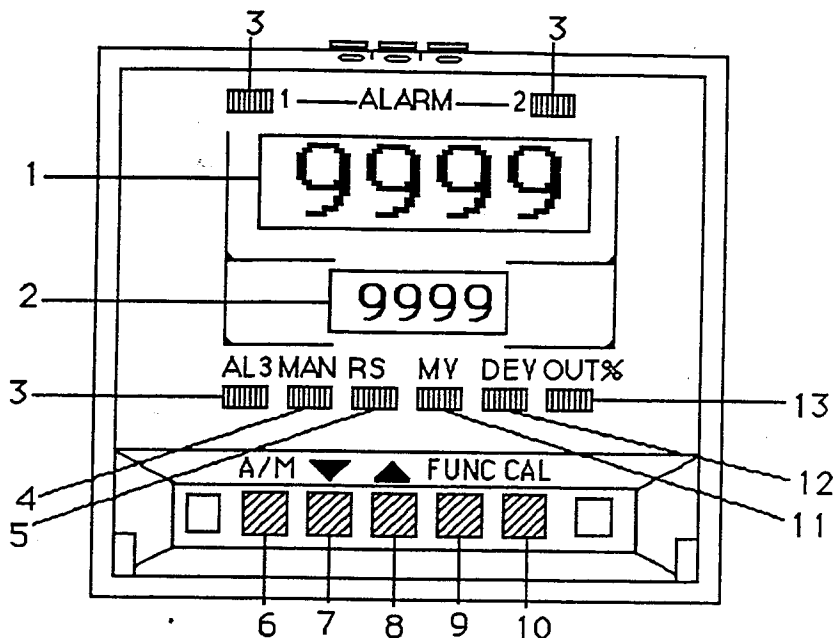

A description of the front panel features follows:

- (1) **UPPER DISPLAY** In the operating mode the upper display shows the measured variable (MV), the deviation of the value from setpoint (DEV), the % of power output (out%), or error codes. Display range is -1999 to +9999.
- (2) **LOWER DISPLAY** In the operating mode the lower display shows setpoint, percent of power output in manual operation and is used to display symbols for parameter adjustment.
- (3) **ALARM LED'S** Lit when the process is in a defined alarm condition.
- (4) **MAN** This LED is on when controller is in manual operation.
- (5) **RS** LED is on when controller is in remote control by a master device via serial commun.
- (6) **A/M** Pushbutton used to change from automatic to manual control and vice versa.
- (7) **DECREMENT** Pushbutton used in parameter setting and in the manual mode to lower power output.
- (8) **INCREMENT** Pushbutton used in parameter modification and to increase power output in manual mode.
- (9) **FUNC** Pushbutton used to scroll and store parameters when in the configure and tuning modes. It is also involved with transducer calibration.
- (10) **CAL** Pushbutton used for transducer calibration.
- (11) **M.V.** This LED is on when the controller is displaying the measured variable.
- (12) **DEV** This LED is illuminated when the upper display shows the deviation value between setpoint and the measured variable.
- (13) **OUT%** This LED is illuminated when the upper display shows the value of power output on a percentage basis.

3-2 OPERATING MODES

μ PC660 has two operating modes which are activated by a DIP switch on the CPU printed circuit board. These modes are:

Configuration Mode: the internal "configure" switch must be ON. In this mode it is only possible to configure the instrument and perform calibration of the outputs. No control action can occur in this mode.

Controller Mode: the internal "configure" switch must be in the OFF position. In this mode the μ PC660 works as a closed loop controller based on the values programmed in the configuration and control modes (tables 1 and 2).

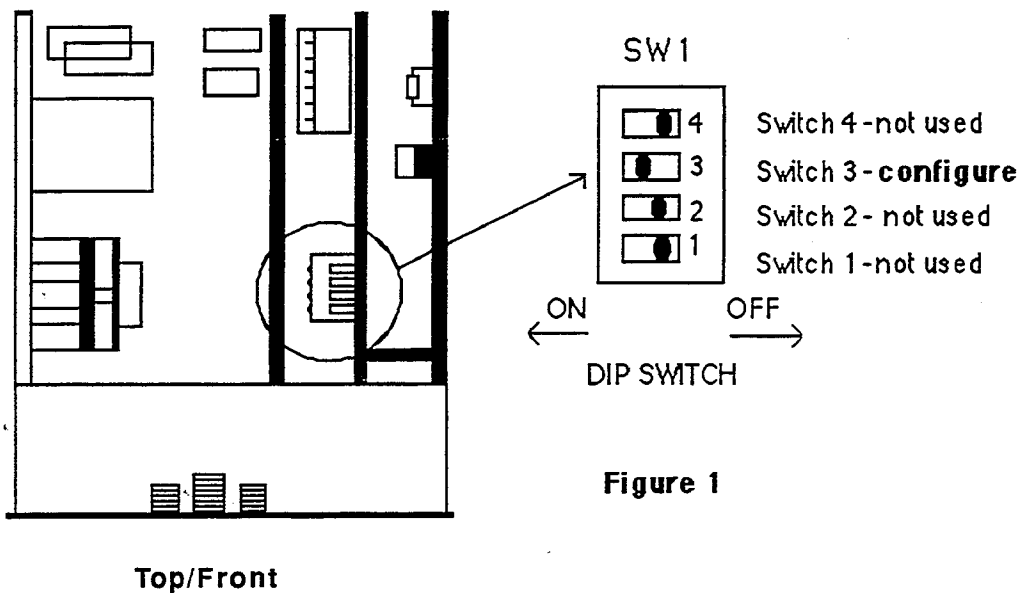

Figure 1

3-3 CONFIGURATION MODE

The configuration mode allows the instrument to be set up to meet the requirements of a specific application. To enter the configuration mode, position the configuration switch #3 into the ON position. Upon entering the configuration mode the units display will show μ PC660.

Pressing the **FUNC** key, the configuration parameters P1 through P16 appear on the lower display (see table 1). By acting on the up/down keys desired criteria can be selected. Pressing **FUNC** again will cause this parameter to be stored in memory and the unit will advance to the next parameter.

PARAMETER LIST (Table 1)

<u>Parameter #</u>	<u>Description</u>	<u>Select</u>
P 1	LINE FREQUENCY	0=50 HZ 1=60 HZ
P 2	CONTROL OUTPUT (refer to Figure 2)	0=0-20 mA 1=4-20 mA 2=0-10 VDC
P 3	DIRECT OR REVERSE ACTION PRIMARY OUTPUT	Refer to Fig. 3
P 4	ALARM 1 CONFIGURATION	SEE BELOW
P 5	ALARM 2 CONFIGURATION	SEE BELOW
P 6	ALARM 3 CONFIGURATION OPTION	SEE BELOW

ALARM 1, 2, 3 CONFIGURATION

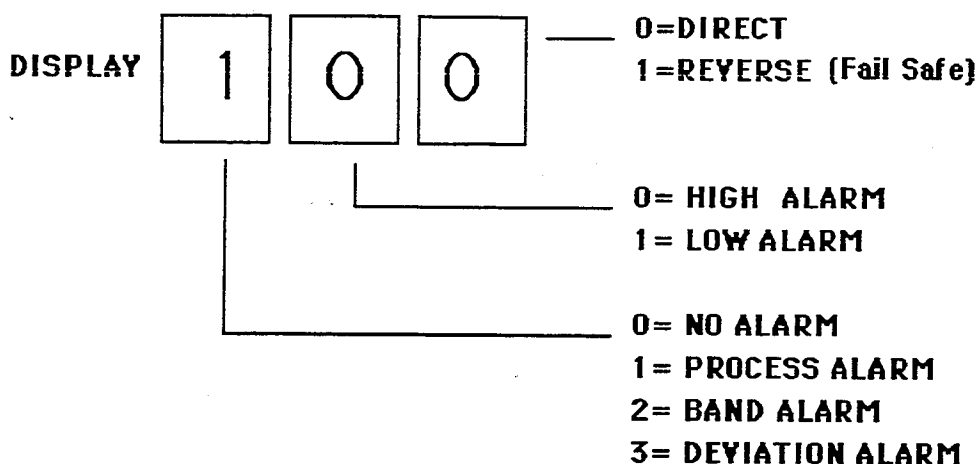

P 7	CALIBRATION TYPE	0=WITHOUT SHUNT 1=WITH SHUNT (FOR DYNISCO MODELS)
P 8	SHUNT PERCENTAGE (WHEN P7 SET TO 1)	40.0 TO 100.0 (80.0 FOR DYNISCO)
P 9*	START UP IN AUTO OR MANUAL	0=START IN AUTO 1=START IN MANUAL
P 10	SERIAL COMMUNICATION ADDRESS	00=NOT PROVIDED 01 THROUGH 31
P 11	BAUD RATE SELECTION	0=150 BAUD 1=300 BAUD 2=600 BAUD 3=1200 BAUD 4=2400 BAUD 5=4800 BAUD 6=9600 BAUD

7=19,200 BAUD

P 12	TRANSMISSION TYPE	0= 7 BITS, EVEN PARITY 1=7 BITS, ODD PARITY 2= 8 BITS, EVEN PARITY 3=8 BITS, ODD PARITY 4=8BITS, NO PARITY
P 13	DISPLAY FILTER	0=OFF 1=ON
P 14	MANUAL TO AUTOMATIC TRANSFER	0=SETPOINT REMAINS AT PROGRAMMED VALUE. 1=SETPOINT TRACKS PROCESSVARIABLE (BUMPLESS).
P 15	AUTO TO MANUAL TRANSFER	0=OUTPUT REMAINS AT PRESENT VALUE 1=OUTPUT GOES TO 0%
P 16	EXTERNAL CONTACT OPTION	0=NOT ACTIVATED 1=ACTIVATED

* this parameter is over-ridden when P16 is activated

Remember to press the **FUNC** key after setting each parameter to lock the selection into memory. At this point unit configuration is completed and the unit will enter the output calibration mode. The μ PC660 is calibrated at the factory; however, if an output calibration is required, refer to section 4-2.

Figure 2

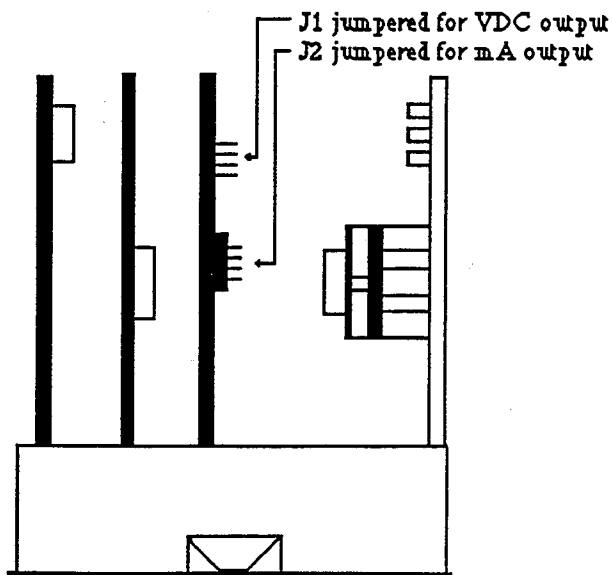

Bottom/Front

NOTE: Jumpers must be positioned to agree with parameter P2

To allow a selection of control output action vs. output value displayed, refer to the table and graphs below.

NOTE: Reverse acting means the control output signal decreases as the input value (pressure) increases. Direct acting means the control output increases as the input increases. The default value is 00.

<u>Parameter P3</u>	<u>Selection</u>	<u>Control Action</u>	<u>Relationship</u>
	00	reverse	Figure 1
	01	direct	Figure 2
	10	direct	Figure 3
	11	reverse	Figure 4

Figure 3

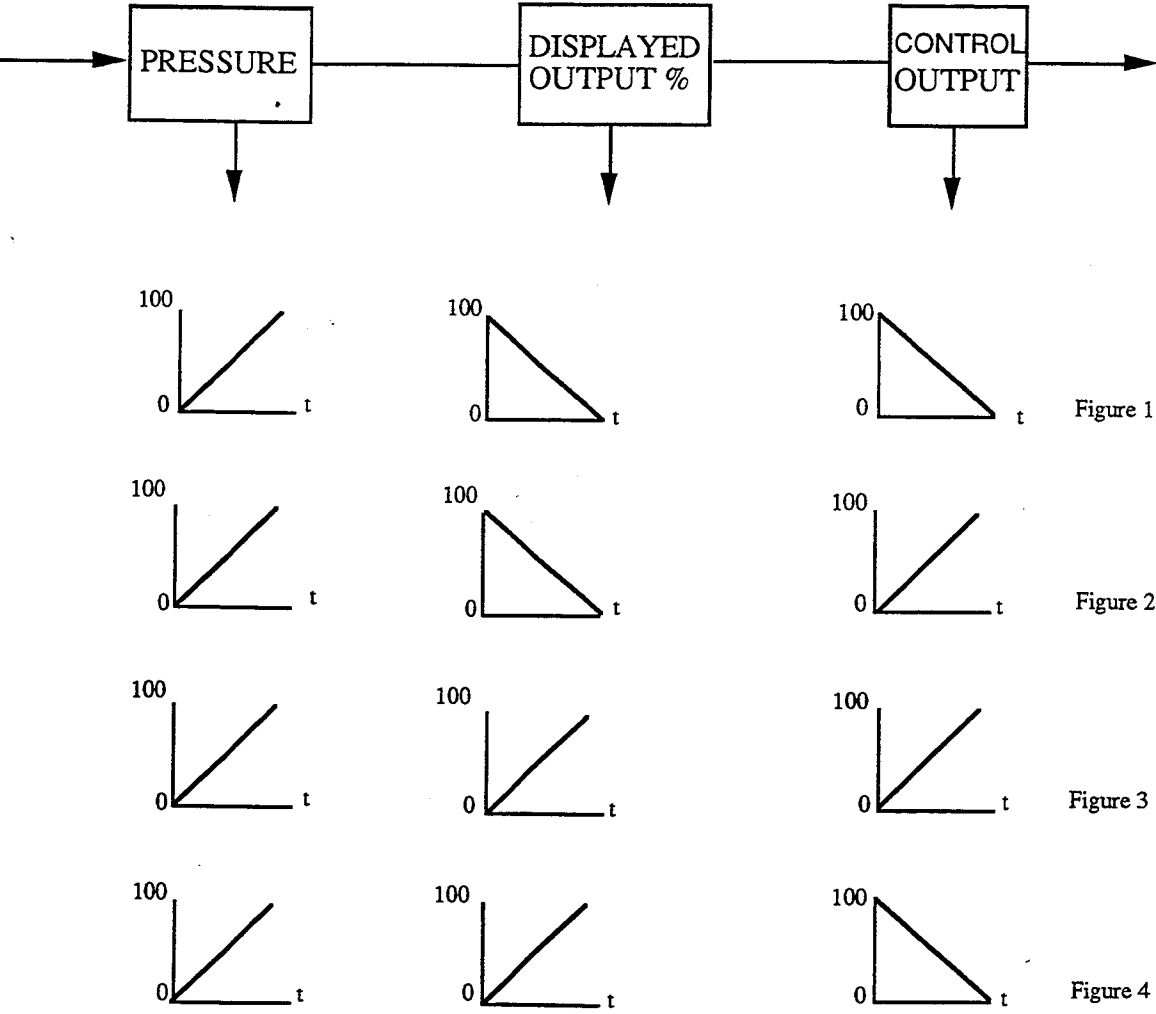

3-4 CONTROLLER MODE

The controller mode is the normal operating mode where the μ PC660 performs as a single loop pressure controller. In this mode, it is possible to view and modify all control parameters listed in Table 2, as well as perform transducer calibration to the controller. To enter this mode, the configure switch must be in the OFF position (Fig. 1).

3-5 TRANSDUCER CALIBRATION

The following procedures are used to calibrate the transducer to the μ PC660. Confirm that P7 and P8 are the proper values to match the sensor being used. For standard 6 wire Dynisco transducers this will be P7 "1" (with shunt), and P8 "80.0" (shunt resistor percentage).

Note: the transducer must be at atmospheric pressure and at normal operating temperature.

1. To begin the calibration procedure, press and hold the **CAL** key and then press the **FUNC** key. At this time the display will indicate 0 on the upper display and C 0 on the lower display. Press **CAL** again. The display will temporarily blank except for one decimal point and the input value will be stored as zero.
2. After the zero calibration, the controller will display the full scale value on the upper display and "C F S" on the lower display. If the value displayed does not match the pressure range of the transducer, use the up/down arrow keys to modify the display to the full range of the transducer. Press the **FUNC** pushbutton and the lower display will show C dP. By using the up/down arrow keys it is now possible to set a decimal point. Press the **CAL** key; again the display will blank and the span value will be calibrated.
3. After the span calibration has been completed the lower display will show "Ct". This parameter is for Tare weight calibration typical in load cell applications. In order to perform the Tare calibration the Tare weight must be applied to the load cell. Then, while the lower display shows Ct, press the **CAL** key to calibrate the value. This portion of the calibration is not required for most pressure transducer applications.

3-6 CONTROL PARAMETERS

When in the controller mode, pressing the **FUNC** key causes the various control parameters to scroll sequentially on the display. To adjust, use the up/down arrow keys and then stock the new value in memory by again pressing the **FUNC** key. The μ PC660 is shipped with certain default values programmed which are explained in Table 2 on the following page.

NOTE: If the controller keyboard is locked, the transducer calibration and control parameters will be inhibited. Refer to section 4-0.

(TABLE 2)

PARAMETER	UPPER DISPLAY	LOWER DISPLAY	UNIT OF MEASUREMENT	DEFAULT VALUE
SET POINT	VALUE OF SP	S P	ENG. UNITS	0
ALARM 1	ALARM 1 SP	A 1	ENG. UNITS	0
ALARM 2	ALARM 2 SP	A 2	ENG. UNITS	0
ALARM 3 (OPTION)	ALARM 3 SP	A 3	ENG. UNITS	0
PROPORTIONAL BAND	PB VALUE	P b	% of full scale	20
INTEGRAL ACTION	INTEGRAL ACTION TIME	t i	SECONDS	60.0
DERIVATIVE ACTION	DERIVATIVE ACTION TIME	t d	SECONDS	0.0
INTEGRAL PRE LOAD	INTEGRAL PRE LOAD	i P	0% TO 100%	50%
ANTIRESET	ANTIRESET VALUE	A	% OF PROP BAND	100%
OUTPUT LIMITER	OUTPUT LIMIT VALUE	O L	% OF POWER OUT	100%
SETPOINT RAMP*	RAMP RATE	r P	ENG. UNITS/SEC.	Blank (no ramp)
LOW LIMIT FOR SP	LOW LIMIT FOR SP	r L	ENG. UNITS	0
HIGH LIMIT FOR SP	HIGH LIMIT FOR SP	r H	ENG. UNITS	9999
EXTERNAL A/M	ON OR OFF	Lntc		OFF

NOTE: Refer to following section for tuning procedures.

* When initiating a setpoint change in the automatic mode, the setpoint will "ramp" to the new setpoint at the rate in rP.

3-7 CONTROLLER TUNING PROCEDURE

The μ PC660 pressure controller will provide stable and accurate pressure control when tuned correctly. The purpose of this procedure is to provide the user with a basic understanding of P. I. D. control so that the operator will be better able to correctly determine the proper P. I. D. values.

First, configure the instrument as outlined in section 3-3. Once the unit has been configured as desired, place the unit in the 'controller' mode as detailed in section 3-2. Refer to section 3-4 and select the desired setpoint and alarm values. Once completed, program the following values as shown:

Proportional Band	110%
Integral Action	5.0 seconds
Derivative Action	0.2 seconds

NOTE: These values are merely suggested values based on various extrusion processes and should provide an 'adequate' starting point. It will be the operator's responsibility to 'fine' tune the controller for the individual process being controlled. Proceed with the programming and note that some of the parameters are pre-programmed with various default values. It is recommended that these values not be changed.

Once programming has been completed, place the controller in the manual mode (LED illuminated) using the front panel A/M button. The upper display will show actual pressure while the lower display will indicate the percent (0-100%) power output. Using the up and down arrow keys, adjust the controller until the lower display indicates '0' output. Start the process and increase power output using the up arrow key. Once the actual process pressure equals the set point (SP) value selected, momentarily observe the process and note the pressure. NOTE: if the process pressure varies wildly at a steady power output, control will be difficult, if not impossible, and can indicate a problem in the mechanical or electrical components of the system.

Press the A/M button initiating automatic control. Observe the process. At this point, pressure variations of ± 50 psi or less should be evident. If the process appears to be unstable with pressure variations above and below setpoint, increase the proportional band until surging abates. If the pressure remains stable but different than the setpoint value, reduce the integral setting (T1) to 3 seconds. Once completed, increase the setpoint approximately 20% and observe the process as the controller attempts to correct the process. If the process appears sluggish returning to setpoint, reduce the proportional setting slightly and/or increase the derivative value to 0.3 seconds. If the process overshoots the setpoint by some large amount and takes an excessively long time to return to setpoint, reduce the anti-reset value until overshoot no longer exists.

It is important to remember that the suggestions made herein are approximations, and that since each process varies the final P. I. D. values used may differ from those suggested.

4-0 KEYBOARD LOCKOUT

After the control parameters (PB, ti, td, etc.) and alarm setpoints have been adjusted, it is possible to inhibit (lock out) the front keyboard. This is accomplished by pressing and holding in sequence the down arrow key, A/M key and CAL key. Each time this sequence is executed the controller will alternate between Lock (Loc) and unlock (unLoc) as shown on the upper display. The setpoint is the only parameter that can be adjusted in the Loc state and that parameter can be limited by rL and rH (see Table 2).

4-1 ERROR MESSAGES

When the unit detects certain faulty conditions it will display an error code. The following is a list of those codes and an explanation of their meaning.

DISPLAY	CONDITION
Err 6	The value of the zero input or "tare" is $> \pm 25\%$ of full scale. For example span is 1000, input value is 300 tare can not occur.
Err 7	The measure value is $> -25\%$ of full scale. Attempt has been made to set the span value negative, or the span value is $< 7\%$ of 50 mV.
□□□□	Over range. The input signal is $> + 125\%$ of the calibrated range or is greater than the maximum display capability (9999)
-□□□	Under range. The input signal is $< -25\%$ of the calibrated range or is lower than the capability of the display (-1999).
OPEN	Transducer line open. One or more of the transducer lines are open. The unit goes upscale (control output goes to zero).
Err 4	The internal auto zero measurement is out of limits. Recalibrate the unit.
Err 5	The internal auto span measurement is out of limits. Recalibrate the unit.

Err 8

At power up the unit finds one or more parameters which are out of fixed limits. Refer to section 4-2 and re-load default parameters.

Err |

Not possible to write to EEPROM. New data is written to RAM. In case of power loss data will be lost.

Err 3

When transferring from manual to auto and affecting a setpoint change the measured variable is outside the limits established by rL and rH.

EEEE
EEEE

Ram failure. Unit needs to be repaired.

NOTE: Send all units requiring repair to Dynisco, attention Repair Coordinator.

4-2 OUTPUT CALIBRATIONS

The μ PC660 control and auxiliary outputs are calibrated at the factory; however, it is possible for the user to perform a calibration as needed. Place the controller in the configuration mode (see figure 1) and scroll through set up parameters P1 - P16 by pressing the FUNC key. After P16, the controller enters the primary output calibration step.

Primary Output Calibration

If the mA control output was selected in P2, the output calibration will begin with C1 (shown in the lower display). Be sure the output jumpers are correctly positioned (figure 2). Connect a 4 $\frac{1}{2}$ digit mA meter to the μ PC660's control output terminals 21(+) and 22 (-). By using the up/down arrow keys of the controller, adjust the mA output to 0.0 mA \pm 100 micro Amps. Press the FUNC key once to advance to C2 then adjust the output to 20.0 mA \pm 100 micro Amps.

If the 0-10 VDC control output was programmed in P2, the output calibration will begin with C3 in the lower display. Connect a 4 $\frac{1}{2}$ digit volt meter to terminals 21 (+) and 22 (-). Via the up/down arrow keys adjust the VDC output to 0.0 VDC \pm 2.5 mV. Press the FUNC key once to advance to C4 then adjust the output to 10 VDC \pm 2.5 mV.

After C4 (for voltage output) or C2 (for mA output) the controller will advance to C5 which is for the 0-5 VDC auxiliary output calibration.

Auxiliary Output Calibration

This calibration procedure is performed at -25% and +125% of span. Connect the volt meter to the μ PC660's rear terminals 2(+) and 3(-). With C5 on the lower display adjust the output with the up/down keys to -1.25 VDC \pm 2 mV. Press FUNC once again to advance to C6 then adjust the output to +6.25 VDC \pm 2 mV. Press the FUNC key once again to lock in the calibration.

4-3 LOADING DEFAULT PARAMETERS

It is possible to load the previously indicated default parameters to make it easier to configure and tune the instrument. Perform the following procedure:

Depending upon which mode the controller is in (i.e., configuration or controller mode) loading the default parameters only affects that mode (refer to section 3-2). Press and hold the down arrow key and then momentarily press the up arrow key. The display will show OFF dEF. Press the up arrow key and the display will appear as On dEF. Press the FUNC key and the display will show LOAd dEF. When the loading procedure has completed the unit will automatically revert to the normal display format.

5-0 SERIAL INTERFACE

μ PC660 can be supplied with RS232C, RS422, or RS485 serial interface. This is an option and can be added to a unit in the field by the adding a piggyback card to the center printed circuit board.

RS 232C PN 820645
RS422 PN 820656
RS485 PN 820657

In order for serial communications to take place μ PC660 must be enabled to operate in a remote condition. To do this close the contacts between terminals 12 and 13. If these contacts should be opened the unit will automatically return to local operating status. Once serial communications has started it is necessary for the host to send a message to any device connected to the party line with no more than 3 seconds between messages. If no message is sent after 3 seconds the unit will return to local status.

5-1 LOCAL/REMOTE SWITCH

Use a free voltage contact. The contact must be able to drive a minimum load of 0.5 mA, 5 Vdc. L/R input is not insulated from main ground.

When the contact is closed the master device can take the control of the instrument. When the contact is open (which signifies either an open circuit or faulty master device) the controller returns to local mode.

When the controller is under control of the master device any operation from the front panel is disabled, only monitoring is possible. In case of an emergency the operator must regain control on the instrument side. In order to be able to obtain this control, a key switch should be connected in series with the L/R contact, and it can be positioned near the instrument. The switch should have the same rating as the L/R contact (see fig. 5.1).

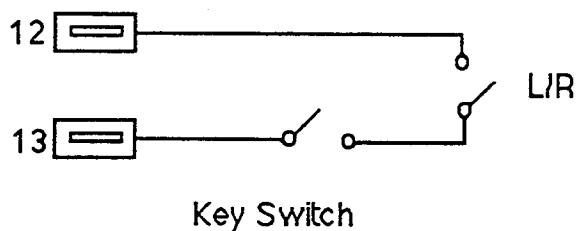
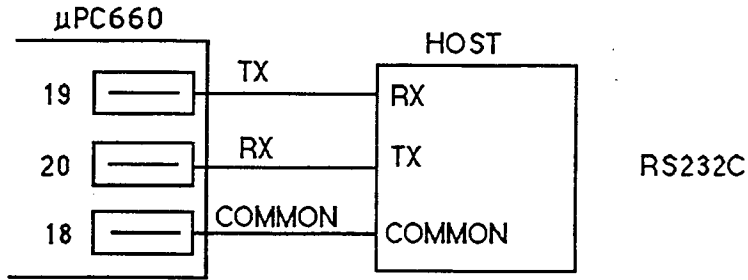

Figure 5.1 LOCAL / REMOTE CONTACT WIRING

5-2 SERIAL COMMUNICATION WIRING

Three types of serial interfaces are offered: RS232C, RS422 and RS485. Some suggested wiring formats follow.



NOTE: Cable length should not exceed 15 m at 9600 Baud.

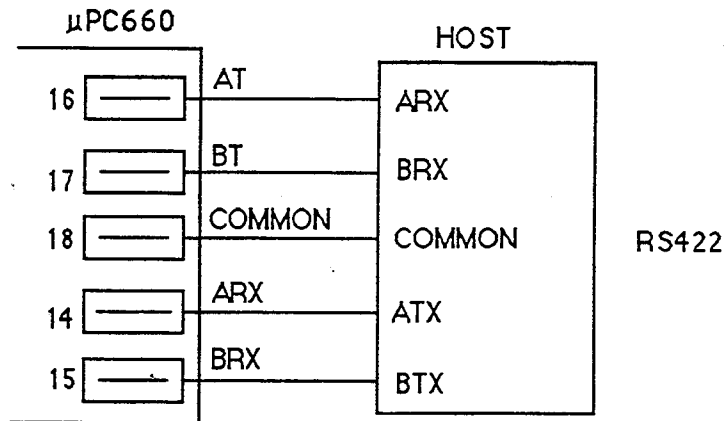

NOTE: Cable length should not exceed 1.5 km at 9600 Baud.

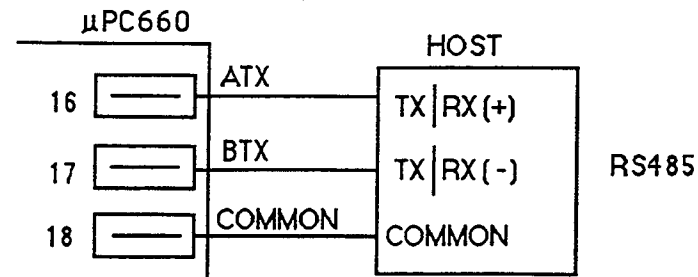

NOTE: Cable length should not exceed 1.5 km at 9600 Baud.

5-3 PROTOCOL (See Separate Operation Manual P/N 974059 For PROTOCOL)

6-0 CONTROLLER DEFINITIONS

Proportional Control - The value shown on the controller is expressed as a percentage of span. The smaller the number, the tighter the control and greater the response of the controller for a certain error. However, selecting a value that is too small tends to make the process unstable (cycling) while too large a value results in a loose response.

Integral Response - aids the controller in returning the process to setpoint. This response is only concerned with the amount of error that exists between the actual pressure and setpoint, and how long (time) the error has existed. The integral response only functions when an error exists. Reducing the value of the integral setting (Ti) increases the amount of integral response. A numerical setting that is too large (40) results in process which will not return to setpoint, while a value which is too small (0.1) will result in an unstable process.

Derivative Response - aids the controller in responding to fast changes in the process. This response is concerned only with the rate of error taking place. The more quickly the actual pressure begins varying from setpoint, the more quickly this function forces the controller to respond. Note that derivative only functions when the error is changing and will not correct for large errors which are stable. Increasing the numerical value of Td increases the amount of derivative response, and decreasing the value decreases the response. While a derivative value which is too small will result in sluggish response to quickly changing errors, a value which is too large will quickly cause an unstable process as the controller attempts to correct for every little variation. This is especially true in extrusion processes.

Integral Preload - assists the controller in recovering from a system upset. To properly adjust, observe the % of power out during steady state control (Section 4-0). The % shown in the lower display is the value that should be programmed into Ip.

Antireset - This is a function that prevents the integral (reset) circuit from activating when the measured pressure is outside a programmed percentage of the proportional band. The smaller the percentage, the closer to setpoint the process pressure must reach before integral action takes place.

Output Limiter - This function reduces the risk of over-reving the extruder during start up by limiting the full output of the controller to a certain percentage (i.e., an output limit of 75% on a 4-20 mA output will limit the full output to 16 mA maximum).

Low/High Limit For SP - These values restrict or set boundaries to where the setpoint can be adjusted. This prevents operators from inadvertently altering the setpoint to high or to low.

Direct Action (Control Output) - The mA output decreases as pressure decreases, and increases as pressure increases.

Reverse Action (Control Output) - The mA output increases as pressure decreases, and decreases as pressure increases.

7-0 ALARM CONFIGURATION EXAMPLES

The following are some examples of the various alarm actions.

NOTE: REVERSE ACTION WORKS ONLY ON THE RELAY'S STATUS

Example:

DIRECT ACTION: LED ON - RELAY ENERGIZED
 LED OFF - RELAY DE-ENERGIZED
REVERSE ACTION: LED ON - RELAY DE-ENERGIZED
 LED OFF - RELAY ENERGIZED

DISPLAY CODE = 100

PROCESS ALARM, HIGH ALARM, DIRECT ACTION

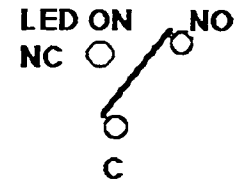
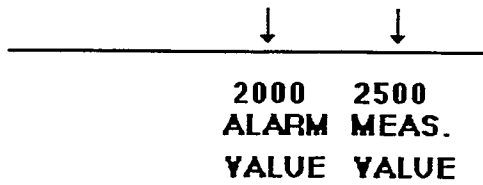
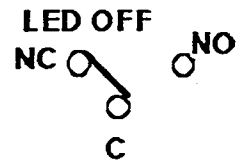
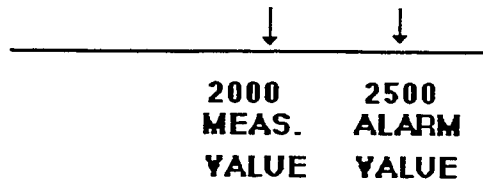

DISPLAY CODE = 110

PROCESS ALARM, LOW ALARM, DIRECT ACTION

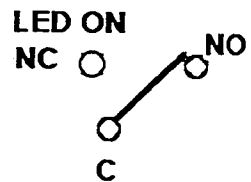
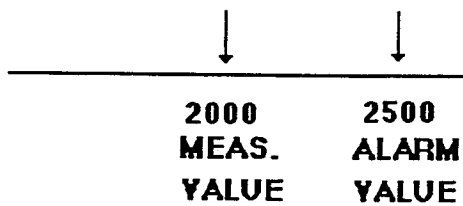
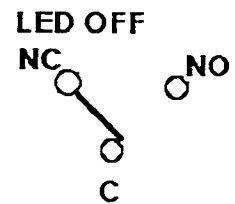
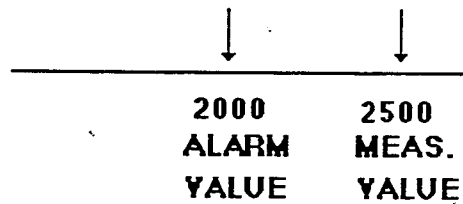

**DISPLAY CODE 200
BAND ALARM, NEUTRAL ZONE OFF, DIRECT ACTION**

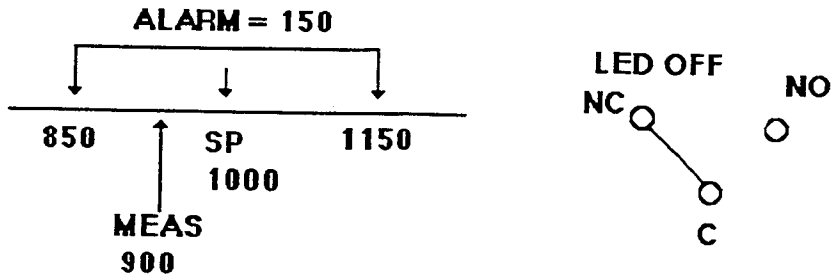

**DISPLAY CODE 200
BAND ALARM, NEUTRAL ZONE OFF, DIRECT ACTION**

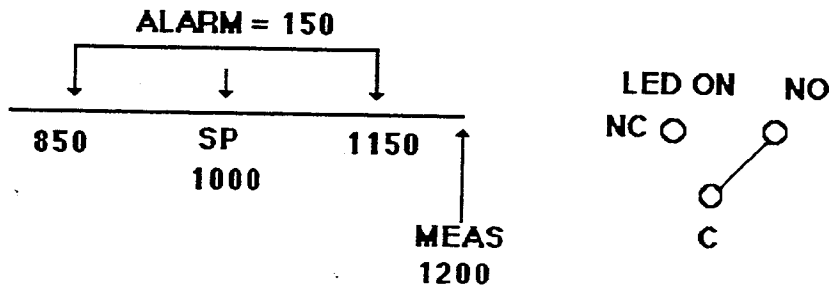

**DISPLAY CODE =300
DEVIATION ALARM, HIGH ALARM, DIRECT ACTION**

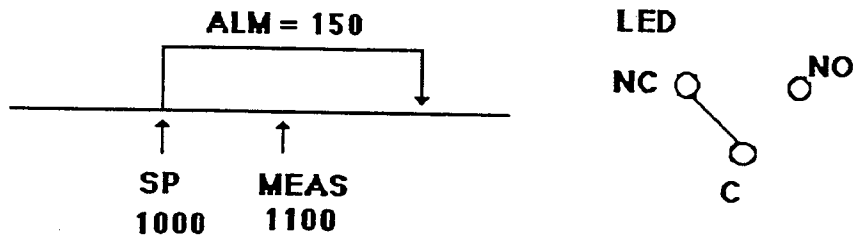

DISPLAY CODE = 300
DEVIATION ALARM, HIGH ALARM, DIRECT ACTION

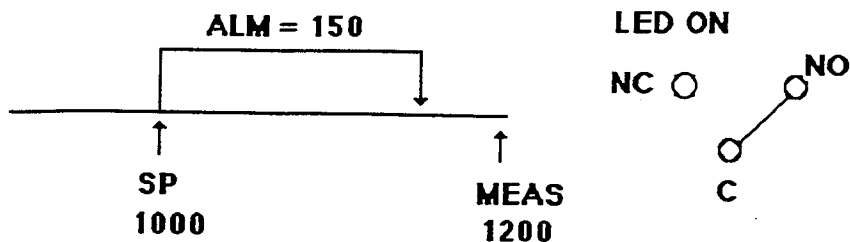

8-0 WARRANTY AND SERVICE

This equipment is sold subject to the mutual agreement that it is warranted by us to be free from defects of material and construction but our liability in connection with it shall be limited to repairing or replacing without charge at our factory any material or construction defects which become apparent within one year from the date on which the equipment is shipped, that we have no liability for damages of any kind arising from the installation and or use of the apparatus by anyone and that the purchaser by the acceptance of this equipment will assume all liability for any damages which may result from its use or misuse by the purchaser, his or its employees or by others. There is no guarantee or warranty or liability except as here stated.

Should the equipment require service or repair, return it freight prepaid to:
Dynisco Instruments 38 Forge Parkway Franklin MA 02038
Attention: Repair Department
Telephone: **508-541-9400**

NOTE: Before returning any product for repair, please call the Dynisco Repair Department for a Return Authorization number.

FOR TECHNICAL ASSISTANCE CALL: (800) 221-2201